

4500



BULLETIN  
No. 530-A

# HYDRAULIC

# WHEEL PRESSES

FOR HIGH SPEED OPERATION



FOR RAILROAD SHOPS

# WATSON-STILLMAN

HYDRAULIC MACHINERY AND EQUIPMENT

## WATSON-STILLMAN WHEEL PRESSES

are furnished in High Speed Oil Hydraulic type.

The oil-operated, inclined type wheel press represents the latest development in machines for forcing wheels on or off axles. A complete range of sizes is available for handling locomotive drivers, and car wheels. These presses offer many installation and operating advantages over models operated by reciprocating plunger type pumps. The pumping unit is of the radial piston type securely bolted to the Cylinder Beam to make a compact unit. The circuit design provides fast traverse speeds and eliminates heavy pullback weights and need for external air supply. The hydraulic power unit, together with the circuit design, assures smooth, shockless operation and pulsationless pressure application with single lever control.

When it is desired to limit the press to less than maximum rated capacity, pressure can be regulated simply and steplessly by adjusting the pump pressure setting against the gauge at a saving in horsepower and electric power.

The simplicity of the design and construction of W-S completely hydraulic presses reduces maintenance. There are no external hydraulic and air lines to maintain, no internal valve, pump or cylinder packings requiring attention. The only soft packing used is in main cylinder stuffing box which is of the self-sealing "V" type and requires infrequent attention. The oil used as operating medium lubricates all internal mechanisms.

A mounting yoke is provided as standard equipment with all presses. It is suspended on a chain attached to a swivel stanchion so it can be swung in and out of pressing position.

As optional equipment, at small additional cost, presses can be supplied with two adjustable sling hooks suspended from rollers. When hooks are furnished the press is equipped with a structural channel to support the rollers so that hooks are on the vertical centerline of the press ram. See drawing on page 5.

Special resistance beams can be supplied in all sizes to admit roller bearing assemblies of diesel wheels or to admit the Spicer generator drive of passenger car wheel sets. Special resistance beams are also available with yoke so that diesel wheel sets incorporating driving gear can be demounted without disturbing the gear.



# WATSON- STILLMAN

**WATSON-  
STILLMAN**

## CONSTRUCTION DETAILS

### PRESS

**CYLINDER BEAM:** Cast steel, smooth bored for guide for Main Ram; packed with chevron type packing under a gland.

**MAIN RAM:** Cast iron, smooth turned and polished.

**TIE BARS:** Rolled Machinery steel of substantial dimensions. Lower bar machined on top face to provide track for Resistance Beam.

**BEARING PINS:** Heat treated alloy steel; provided with handle for easy removal or insertion into tie bar.

**RESISTANCE BEAM:** Cast steel, supported by rollers on lower tie bar and easily moved by means of hand lever and ratchet arrangement. Rollers are fitted with needle type roller bearings. Gap in the resistance beam accommodates the projecting end of axle and is slotted to receive a filling block when a solid abutment is desired.

**REAR STAND:** Welded steel and is offset so that long shafts can extend beyond the frame.

### PUMP AND CONTROL

**PUMPING UNIT:** Power is supplied by a radial piston pump directly coupled to a constant speed electric motor of the required current characteristics. Push button starter control with magnetic starter is supplied. Pump and motor are mounted on the oil tank. This tank is of welded steel construction and is provided with air breather, oil level gauge, and access covers.

**CONTROL:** A single hand lever controls the press by means of a four-way valve. Moving the lever to forward provides rapid traverse to the work and automatic change to the slower pressing speed when ram reaches work. Placing control lever in return provides rapid return. Placing control lever in neutral by-passes pump and stops press. A control rod is provided to automatically throw the control lever into neutral at the end of return stroke. The control rod also is operated on the forward stroke to prevent overstroking.

### GENERAL

No base plate is required with a wheel press of this design. However, a concrete foundation is recommended. Depth of foundation is governed by character of the soil.



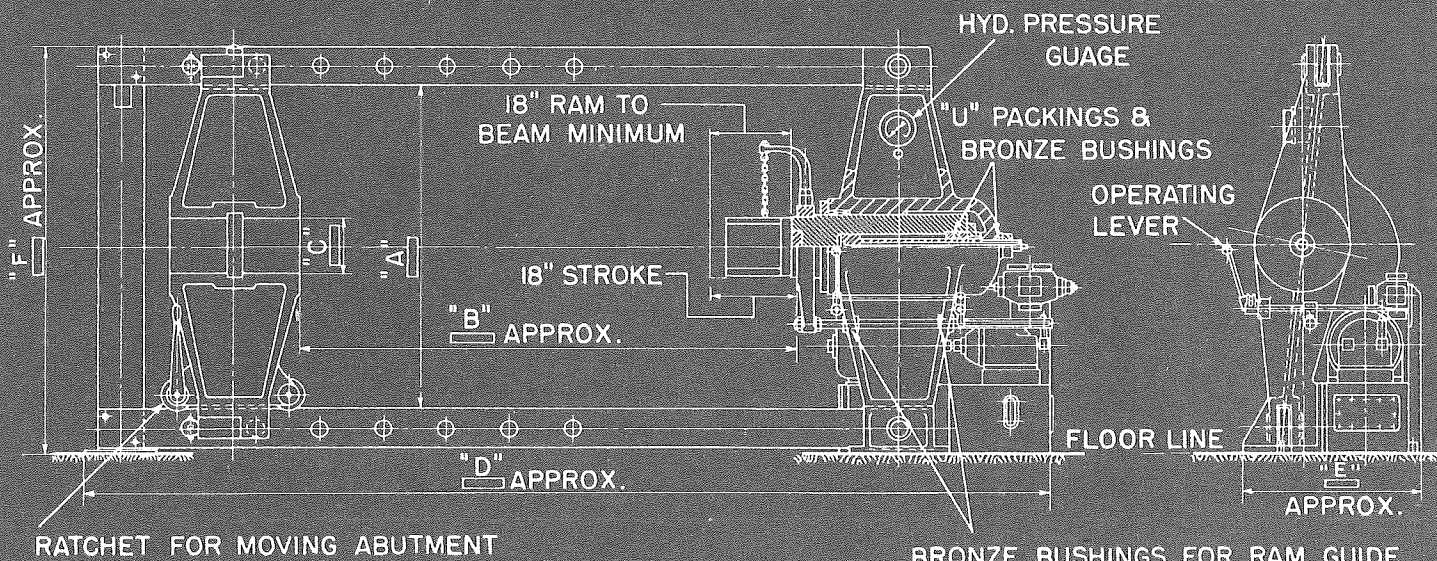

BRONZE BUSHINGS FOR RAM GUIDE & OVERSTROKE CONTROL ROD

NOTE: JACK RAM IS NOT USED ON 100, 150 AND 200 TON MODELS



# W H E E L P R E S S E S

RAM TO BEAM MAX. "B"	RAM TO BEAM MIN.	GAP IN BEAM "C"	MOTOR		FLOOR SPACE (APPROX.)		
			H.P.	R.P.M.	D	E	F
8'-6"	18"	6"	3	1200	15'-1"	33"	5'-0"
8'-6"	18"	6"	3	1200	15'-1"	33"	6'-0"
8'-6"	18"	8½"	5	1200	15'-11"	3'-0"	5'-2"
8'-6"	18"	8½"	5	1200	15'-11"	3'-0"	7'-2"
8'-6"	18"	10½"	7½	1200	16'-5"	3'-4"	5'-4"
8'-6"	18"	10½"	7½	1200	16'-5"	3'-4"	6'-4"
8'-6"	18"	10½"	7½	1200	16'-5"	3'-4"	7'-4"
9'-0"	18"	10½"	7½	1200	16'-11"	3'-5"	5'-7"
9'-0"	18"	10½"	7½	1200	17'-1"	3'-5"	6'-7"
9'-0"	18"	10½"	7½	1200	17'-3"	3'-5"	7'-7"
9'-0"	18"	12½"	10	1200	17'-8"	3'-6"	6'-3"
9'-0"	18"	12½"	10	1200	17'-8"	3'-6"	7'-3"
9'-0"	18"	12½"	10	1200	18'-3"	3'-6"	7'-9"
9'-0"	18"	12½"	10	1200	18'-3"	3'-6"	8'-9"
9'-0"	18"	12½"	10	1200	18'-6"	3'-6"	9'-9"
9'-0"	18"	12½"	15	1200	18'-0"	3'-10"	6'-5"
9'-0"	18"	12½"	15	1200	18'-6"	3'-10"	8'-11"
9'-0"	18"	12½"	15	1200	18'-6"	3'-10"	9'-11"
9'-0"	18"	12½"	20	1200	18'-4"	4'-0½"	6'-8"
9'-0"	18"	12½"	20	1200	18'-4"	4'-0½"	8'-2"
9'-0"	18"	12½"	20	1200	18'-8"	4'-0½"	9'-2"
9'-0"	18"	12½"	20	1200	18'-11"	4'-0½"	10'-6"
9'-0"	18"	15½"	20	1200	19'-2"	4'-4"	8'-6"
9'-0"	18"	15½"	20	1200	19'-4"	4'-4"	9'-6"
9'-0"	18"	15½"	20	1200	19'-4"	4'-4"	10'-10"

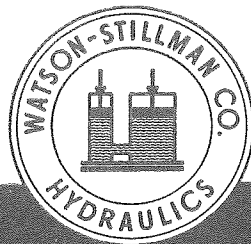
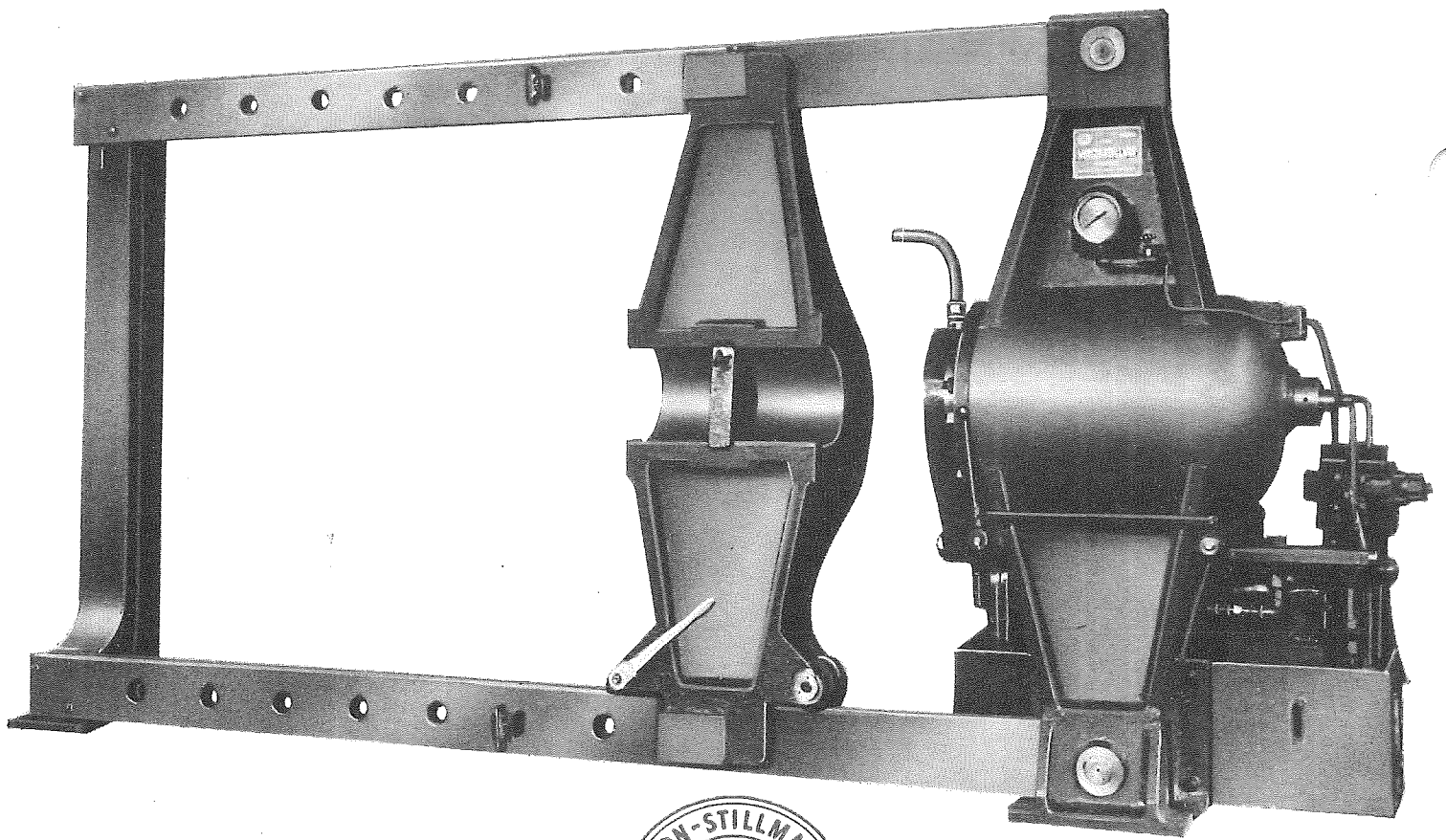

## S T A N D A R D   I N C L I N E D

MACH. NO.	TONS	BETWEEN BARS "A"	RAM STROKE	SPEEDS INCH/MIN.		
				ADV.	PRESS	RETURN
9571	100	48"	18"	61"	6.0"	52"
9572	100	60"	18"	61"	6.0"	52"
9574	150	48"	18"	81"	7.3"	78"
9576	150	72"	18"	81"	7.3"	78"
9577	200	48"	18"	62"	9.6"	125"
9578	200	60"	18"	62"	9.6"	125"
9579	200	72"	18"	62"	9.6"	125"
9581	300	48"	18"	55"	6.7"	84.5"
9582	300	60"	18"	55"	6.7"	84.5"
9583	300	72"	18"	55"	6.7"	84.5"
9584	400	54"	18"	57"	7.8"	84"
9585	400	66"	18"	57"	7.8"	84"
9586	400	72"	18"	57"	7.8"	84"
9587	400	84"	18"	57"	7.8"	84"
9588	400	96"	18"	57"	7.8"	84"
9589	500	54"	18"	57"	7.0"	84"
9590	500	84"	18"	57"	7.0"	84"
9591	500	96"	18"	57"	7.0"	84"
9619	600	54"	18"	68"	8.4"	100"
9620	600	72"	18"	68"	8.4"	100"
9573	600	84"	18"	68"	8.4"	100"
9621	600	100"	18"	68"	8.4"	100"
9575	800	72"	18"	54"	6.3"	80"
9580	800	84"	18"	54"	6.3"	80"
10019	800	100"	18"	54"	6.3"	80"

# HIGH SPEED MOUNTING AND DEMOUNTING PRESSES



In addition to our standard line of wheel presses covered by this bulletin we also manufacture presses for production mounting and demounting of car wheels and diesel wheels. The press time for these machines is less than one minute per axle and wheel assembly.

**THE MOUNTING PRESS** features automatic fixtures and full accessibility by eliminating overhead bar of the conventional two bar presses. The machine is designed for straight-through production and, although of single-end type, mounts both wheels without turning the wheel assembly around. The wheels are mounted one at a time so that individual record of mounting pressures is maintained. The fixtures and axle shifting cylinder are controlled from the operating station, eliminating manual handling of blocks and manual shifting of the wheel assembly.

**THE DEMOUNTING PRESS** incorporates swinging yoke for diesel wheel sets incorporating driving gear to permit demounting the wheel without disturbing the gear. The press is of double-end type and, although demounting is accomplished one wheel at a time, the fast demounting and traverse speeds make the machine the highest production demounting press available. The machine is designed for handling maximum range of wheel sets without the need of spacers and pressure blocks. All press movements are controlled from a single operating station, and positive protection is provided in each cylinder against overstroking. The demounting press is also available for handling wheel sets incorporating Spicer generator drive. In this case the abutment is designed to admit the housing of the drive so that wheels can be demounted without disturbing the drive.

These presses are long stroke machines assuring long production runs without the manual handling of fixtures. Presses are of modern high speed oil type with push button controls providing finger tip control of all ram movements from single control station. General specifications are detailed below. Complete information is available on request.

**MOUNTING PRESS**—300 Ton Capacity—Open Frame Design—Single end type—Maximum Wheel Diameter—42"—Motor HP—30—Automatic Air powered mounting tools with air axle shifting cylinder—Wheel press recorder and stroke indicator.

**DEMOUNTING PRESSES**—400 Ton and 600 Ton Capacity. Double end type two bar design with center fixed abutment equipped with swinging yoke. Maximum wheel diameter—42"—Motor 40 HP for 400 Ton Machine—Motor 50 HP for 600 Ton Machine.

**WATSON-  
STILLMAN**

# W-S PRODUCTS FOR RAILROAD SHOPS

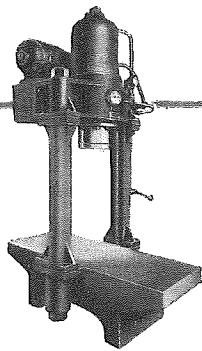

**BUSHING PRESS**

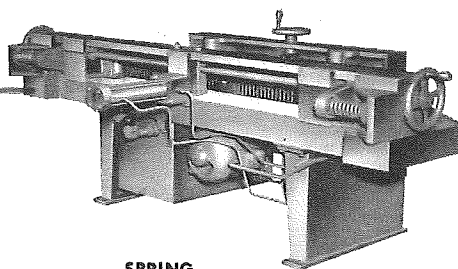

**SPRING FORMING PRESS**

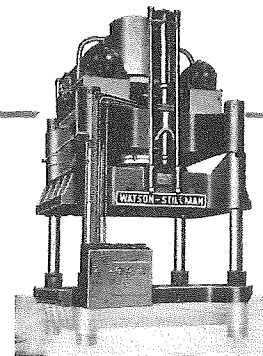

**METAL FORMING PRESS**

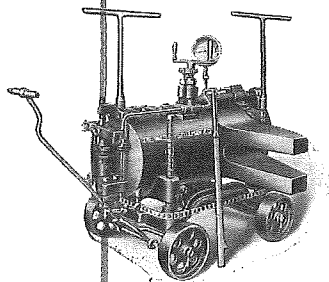

**CRANK PIN AND FORCING PRESS**

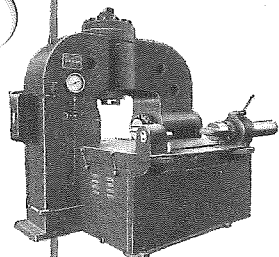

**SPRING BANDING PRESS**

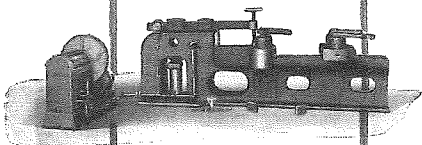

**WALTER STOCK ADJUSTING MACHINE**

## OTHER BULLETINS AVAILABLE

- BUSHING PRESSES—Bulletin 520-A
- RAIL BENDERS—Bulletin 560-A
- SPRING STRIPPING MACHINES—Bulletin 550-A
- SPRING BANDING PRESSES—Bulletin 550-A
- SPRING FORMING PRESSES—Bulletin 550-A
- SPRING TESTING MACHINES—Bulletin 550-A
- CRANK PIN AND FORCING PRESSES—Bulletin 560-A
- WALTER STOCK ADJUSTING MACHINES—Bulletin 540-A
- PULLING JACKS—Bulletin 560-A
- PIPE BENDERS—Bulletin A-5
- HAND PUMPS—Bulletin 240-A
- HYDRAULIC JACKS—Bulletin 710-A
- FORGED STEEL FITTINGS—Bulletin A-3

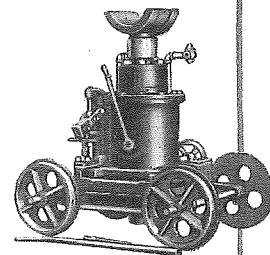

**PIT JACK**

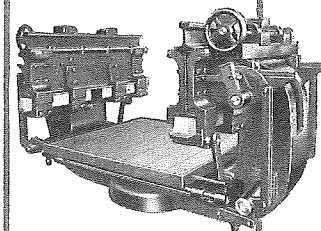

**DROP PIT TABLE**

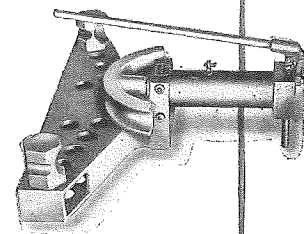

**PORTABLE PIPE BENDER**

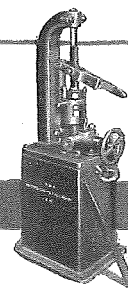

**HAND PUMP**

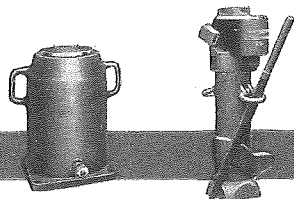

**HYDRAULIC JACKS**  
Independent Pump Type • Claw Type

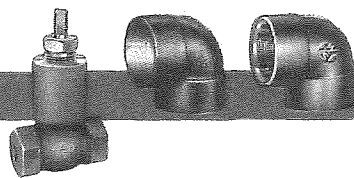

**FORGED STEEL FITTINGS AND VALVES**