



ANGUS SINCLAIR

# LOCOMOTIVE ENGINE RUNNING

AND

## MANAGEMENT.

*Showing How to Manage Locomotive in Running Different Kinds of Trains with Economy and Dispatch; Giving Plain Descriptions of Valve-Gear, Injectors, Brakes, Lubricators, and Other Locomotive Attachments; Treating on the Economical Use of Fuel and Steam; and Presenting Valuable Directions about the Care, Management, and Repairs of Locomotives and their Connections.*

BY

ANGUS SINCLAIR,

*Member of the Brotherhood of Locomotive Engineers; of the American Railway Master Mechanics' Association; of the American Society of Mechanical Engineers, etc.*

TWENTY-SECOND EDITION, REVISED AND ENLARGED.

TOTAL ISSUE, TWENTY-FOUR THOUSAND.



NEW YORK :

JOHN WILEY & SONS.

LONDON : CHAPMAN & HALL, LIMITED.

TJ 607  
S6  
1908

**GENERAL**

Copyright, 1899, 1908,

BY

**ANGUS SINCLAIR.**

## PREFACE.

---

WHILE following the occupation of a locomotive engineer, I often observed peculiarities about the working of my engine, while running, that I did not entirely understand. As I was perfectly aware, even before making my first trip on a locomotive engine, that there is no effect without a cause, I never felt satisfied to accept any thing as incomprehensible without investigation, and fell into the habit of noting down facts about the working of the engine, with the view of studying out, at leisure, any thing which was not quite clear. When, some years ago, I abandoned engine-running to take charge of the round-house at the mechanical headquarters of the Burlington, Cedar Rapids, and Northern Railway, in Iowa, the practice of keeping notes was continued. The work connected with the ordinary repairing of running-engines, the emergency repairing executed to get engines ready hurriedly to meet the traffic demands on a road then chronically short of power, and diagnosing the nu-

merous diseases that locomotives are heir to, provided ample material for voluminous notes. Those notes formed the raw material from which this book was constructed.

The original intention was, to publish a book on Locomotive Engine Running alone, and the first portion of the work was prepared with that idea in view; but, before the articles were finished, I joined the editorial staff of the *American Machinist*. The correspondence in the office of that paper convinced me that an urgent demand existed, among engineers, machinists, and others, for plainly given information relating to numerous operations connected with the repairing and maintenance of locomotives. To meet this demand, the chapters on "Valve-Motion" and all the succeeding part of the book were written. Most of that matter was originally written for the pages of the *American Machinist*, but was afterwards re-arranged for the book.

In preparing a book for the use of engineers, firemen, machinists, and others interested in locomotive matters, it has been my aim to treat all subjects discussed in such a way that any reader would easily understand every sentence written. No attempt is made to convey instruction in any thing beyond elementary problems in mechanical engineering, and all problems brought forward are treated in the simplest manner possible.

The practice of applying to books for information concerning their work, is rapidly spreading among the engineers and mechanics of this school-spangled country; and this book is published in the hope that its pages may furnish a share of the needed assistance. Those men, who, Socrates-like, search for knowledge from the recorded experience of others, are the men, who, in the near future, will take leading places in our march of national progress. To such men, who are earnestly toiling up the steep grade of Self-help, this book is respectfully dedicated.

ANGUS SINCLAIR.

NEW YORK CITY,

Jan. 1, 1885.

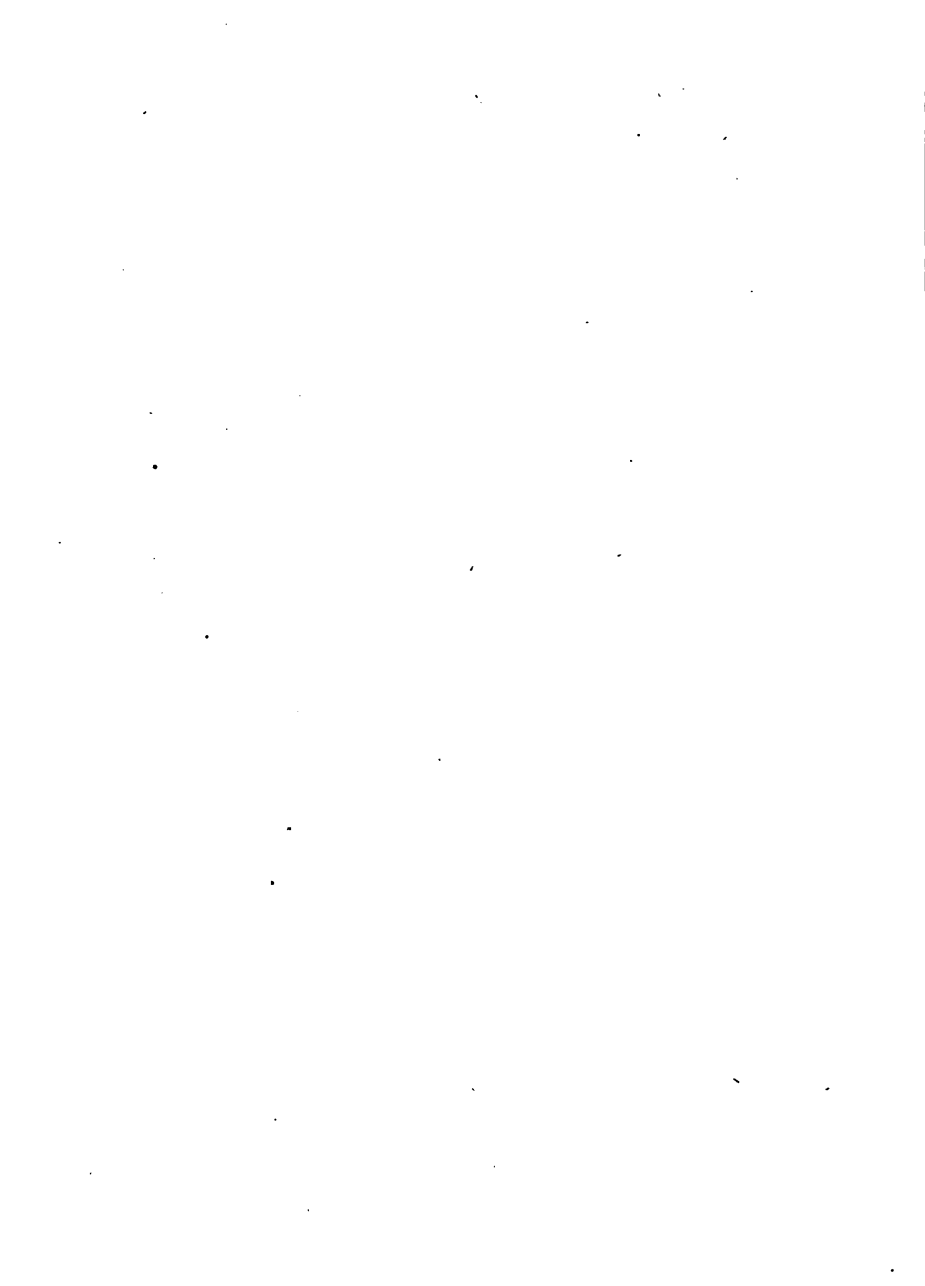

## PREFACE TO TWENTY-SECOND EDITION.

---

THE period of twenty-three years and a half that elapsed since the first edition of *Locomotive Engine Running and Management* was published has seen the introduction of many additions to the appliances used in operating the locomotive, but the engine itself has been changed very little, except being made larger. Progress in locomotive engineering is largely represented by improvements upon the appliances referred to, and to the introduction of new ones. In preparing the twenty-second edition of *Locomotive Engine Running and Management* it has been my aim to make the book a certain and safe manual of instruction to the modern locomotive engineer. The best practice in handling locomotives has been made as plain as possible and the principles of locomotive engineering, which embraces information concerning heat, steam, and motive power, have been explained in words that will be understood by every person who can read.

Strict examination before promotion is every day becoming more exacting for those to be trusted with the running of locomotives. In view of this condition so important to train men, I have devoted unusual space to a catechism of motive power and of train operating.



Locomotive Engine Running and Management has been a guide, tutor, and friend to many railroad men, and thousands of officials are willing to admit that it helped them to climb the ladder of progress. The twenty-second edition is offered in the confident conviction that it will be more useful to future generations than the previous editions have been to those now sustaining the heat and burden of the day.

# CONTENTS.

---

INTRODUCTION.....	PAGE xiii
-------------------	--------------

## CHAPTER I.

ENGINEERS AND THEIR DUTIES.....	..
---------------------------------	----

## CHAPTER II.

HOW ENGINEERS ARE MADE.....	12
-----------------------------	----

## CHAPTER III.

INSPECTION OF THE LOCOMOTIVE.....	24
-----------------------------------	----

## CHAPTER IV.

GETTING READY FOR THE ROAD.....	33
---------------------------------	----

## CHAPTER V.

RUNNING A FAST FREIGHT TRAIN.....	42
-----------------------------------	----

## CHAPTER VI.

GETTING UP THE HILL.....	59
--------------------------	----

## CHAPTER VII.

FINISHING THE TRIP.....	71
-------------------------	----

## CHAPTER VIII.

	PAGE
HARD-STEAMING ENGINES.....	79

## CHAPTER IX.

SHORTNESS OF WATER.....	93
-------------------------	----

## CHAPTER X.

BOILERS AND FIRE-BOXES.....	115
-----------------------------	-----

## CHAPTER XI.

ACCIDENTS TO THE VALVE-MOTION.....	125
------------------------------------	-----

## CHAPTER XII.

ACCIDENTS TO CYLINDERS AND STEAM-CONNECTIONS.....	146
---------------------------------------------------	-----

## CHAPTER XIII.

OFF THE TRACK—ACCIDENTS TO RUNNING-GEAR.....	156
----------------------------------------------	-----

## CHAPTER XIV.

CONNECTING-RODS, SIDE-RODS AND WEDGES.....	167
--------------------------------------------	-----

## CHAPTER XV.

VALVE-MOTION.....	185
-------------------	-----

## CHAPTER XVI.

THE SHIFTING-LINK.....	218
------------------------	-----

## CHAPTER XVII.

SETTING THE VALVES.....	236
-------------------------	-----

## CHAPTER XVIII.

THE WESTINGHOUSE AIR-BRAKE.....	247
---------------------------------	-----

*CONTENTS.*

**xi**

**CHAPTER XIX.**

	<b>PAGE</b>
<b>TRACTIVE POWER AND TRAIN RESISTANCE.....</b>	<b>309</b>

**CHAPTER XX.**

<b>DRAFT APPLIANCES.....</b>	<b>321</b>
------------------------------	------------

**CHAPTER XXI.**

<b>COMBUSTION.....</b>	<b>332</b>
------------------------	------------

**CHAPTER XXII.**

<b>STEAM- AND MOTIVE-POWER.....</b>	<b>353</b>
-------------------------------------	------------

**CHAPTER XXIII.**

<b>SIGHT-FEED LUBRICATORS.....</b>	<b>360</b>
------------------------------------	------------

**CHAPTER XXIV.**

<b>EXAMINATION OF FIREMEN FOR PROMOTION.....</b>	<b>381</b>
--------------------------------------------------	------------





LIBRARY  
OF THE  
UNIVERSITY  
OF  
CALIFORNIA

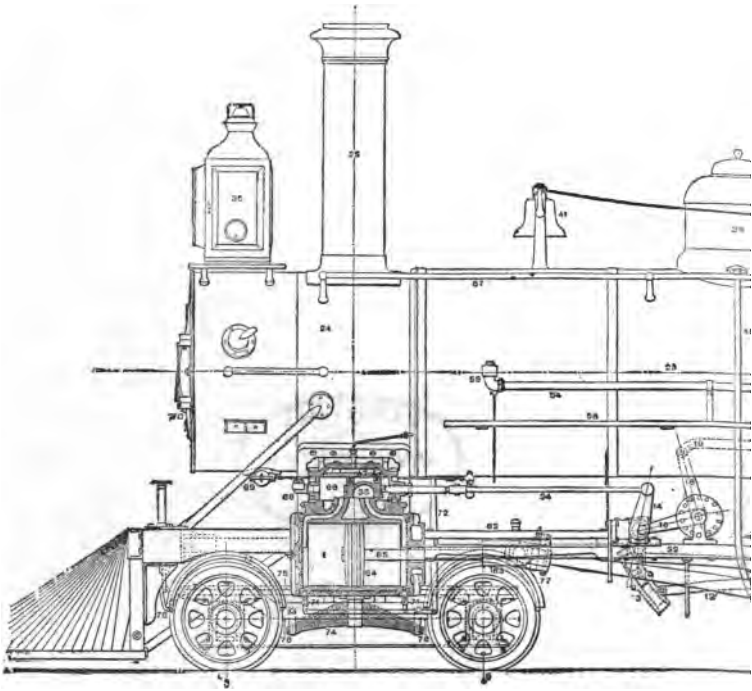

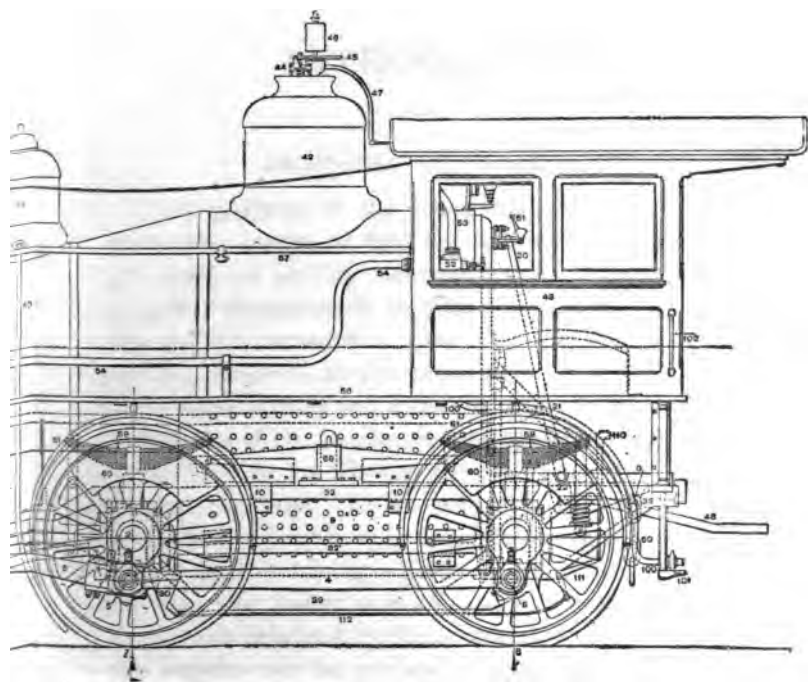

LATE A.

To face p. xiii.







## INTRODUCTION.

---

### *DESIGNING OF LOCOMOTIVES.*

THE purpose of the locomotive engine is to transform the energy of fuel by the medium of steam into the work of pulling railroad trains. The leading aim of good designers is to plan locomotives that will do the greatest amount of work with the least expenditure of fuel, and will at the same time be safe, convenient to handle, strong and durable. The two most important parts of the locomotive are the boiler and the cylinders. These are like the stomach and the heart of the human machine. In the boiler the steam is generated, and it is used in the cylinders, transmitting the resulting power to the driving wheels. In a well-designed locomotive, the boiler is made large enough to supply all the steam required by the cylinders no matter how hard the engine may be worked or how fast it may be run.

### DESCRIPTION OF ORDINARY LOCOMOTIVE.

In most of the engravings to be found at this part of the book the outlines and principal parts of an ordinary eight-wheel locomotive are shown. Plate A is a side elevation of the engine, and shows all the outside parts that can be seen by a person standing near the engine. The cylinder and steam chest are, however, shown in

cross section giving the view of these parts that would be obtained if they were cut down through the center as one might cut a water-melon lengthwise, or as train men sometimes see Westinghouse brake apparatus cut to show the working of the parts. It is for the same purpose that this cylinder and steam-chest are seen cut open in the drawing. The upper part in Plate B represents the boiler and fire-box of the engine cut in cross-section. The lower figure is a plan of the engine with the boiler removed, but with the outlines of the fire-box, mud-ring, and the grates in place. This view shows the engine as we would see it, after the boiler was removed, by standing on the frame and looking downward. In the left-hand view of Plate C, the engine appears as it is seen from behind when the tender is taken away. The right-hand view is a transverse section through the smoke-box, cylinders, and center pin of the truck. This is what would be seen if the front of the engine were sliced clean through these parts.

#### BOILER AND FIRE-BOX.

A locomotive boiler is peculiar in having the furnace and boiler all inclosed in one shell. The fire-box is an oblong box of steel sheet about  $\frac{5}{8}$  inch thick. A water space about  $3\frac{1}{2}$  inches wide intervenes between the fire-box and the outside shell, the two being securely fastened together by stay-bolts about  $\frac{7}{8}$  inch thick and 4 inches apart. The small circles seen on the side of the fire-box in the figures represent the stay-bolts.

The boiler of the engine shown is of the wagon-top kind. That is, the waist or barrel of the boiler is



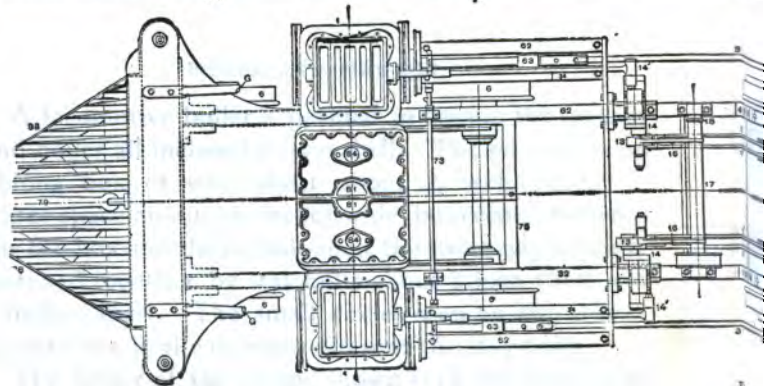
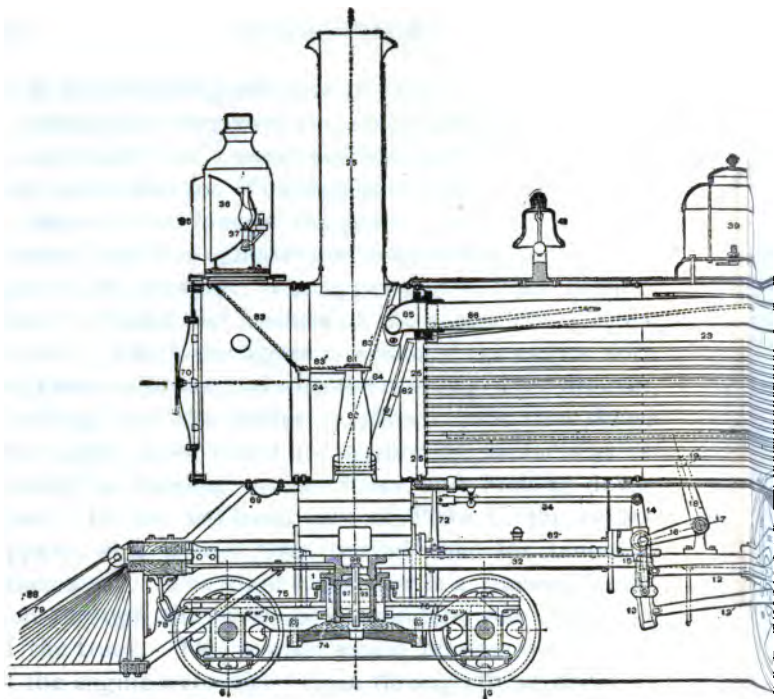

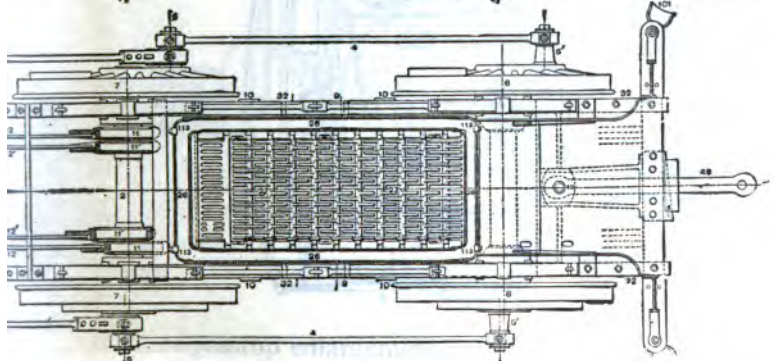
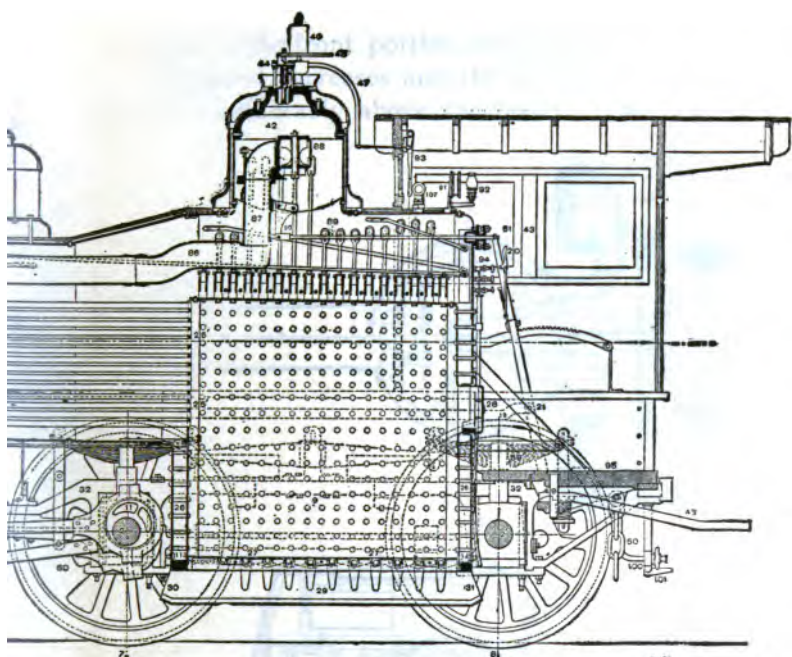

PLATE B.

To face p. xiv.

1. The first part of the document discusses the importance of maintaining accurate records of all transactions and activities. It emphasizes that proper record-keeping is essential for transparency and accountability, particularly in the context of public administration and financial management. The text notes that without reliable records, it is difficult to track the flow of funds and ensure that resources are being used as intended.

2. The second part of the document outlines the various methods and tools used for data collection and analysis. It mentions the use of surveys, interviews, and focus groups to gather qualitative data, as well as the application of statistical software for quantitative analysis. The author highlights the need for a systematic approach to data collection to ensure that the information gathered is both valid and reliable.

3. The third part of the document addresses the challenges of data management and storage. It discusses the importance of having a secure and accessible database system to store large volumes of data. The text also touches upon the issue of data privacy and the need to implement appropriate safeguards to protect sensitive information from unauthorized access or disclosure.

4. The fourth part of the document focuses on the dissemination and use of research findings. It stresses the importance of communicating the results of the study to the relevant stakeholders in a clear and concise manner. The author suggests that this can be achieved through the publication of reports, the organization of workshops, and the use of other communication channels. The goal is to ensure that the findings are not only understood but also acted upon to bring about positive change.

5. The final part of the document provides a conclusion and offers some recommendations for future research. It reiterates the significance of the study and the need for continued efforts to improve data management practices and the use of research findings in policy-making. The author encourages further exploration of emerging technologies and methodologies to enhance the effectiveness of data-driven decision-making.

straight in the front portion, but towards the fire-box the diameter increases and the top of the fire-box is raised considerably above the boiler. The object of

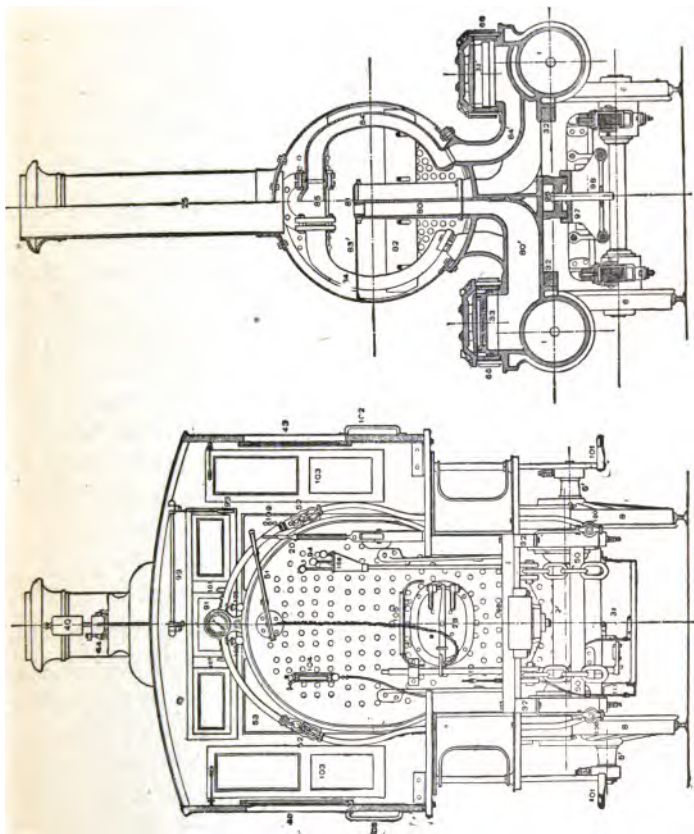

PLATE C.

the wagon-top enlargement is to increase the space for holding steam. The dome in this form of boiler is nearly always placed on the wagon-top. The purpose



of the dome is to raise the inlet of the "dry-pipe" which carries the steam to the cylinders, away as far as possible above the water level.

As the top of most of inside fire-boxes is flat, it needs to be supported or the pressure of steam inside would bend it down and tear the sheets. In this boiler the crown-sheet is supported by crown bars whose ends may be seen above the fire-box in Plate B. These in turn are reinforced by sling-stays binding them to the outer shell. These sling-stays can be seen above the crown-bars. Stay-bolts bind the crown-sheet and the crown-bars securely together. The tubes or flues that connect the fire-box and the smoke-box are about two hundred in number, and are generally 2 inches diameter. These flues form so many small chimneys to carry away the hot gases from the fire; and being surrounded by the water inside the boiler, the heat is quickly given up to the water. This "multi-tubular" arrangement of the boiler enables the steam to be generated with great rapidity,

#### HOW STEAM MOVES THE ENGINE.

When a locomotive is ready for raising steam, the boiler is filled with water till the crown-sheet of the fire-box is well covered. When the water in the boiler begins to get low, this crown-sheet is the first part exposed to the fire to become uncovered, and great care must be exercised to prevent this while there is fire in the fire-box, for the dry sheets are quickly destroyed when exposed to a hot fire.

The water being put in to cover the crown-sheet, a fire is started in the fire-box and steam is quickly raised.

When the engineer gets ready to move the engine, he puts the reverse lever 20 (Plate B) in forward or back motion, which puts the eccentric-rod 12 or 12' opposite the bottom rocker-pin and gives one of the rods the power to operate the slide-valve 33 (Plate A) for the direction the engine is intended to be run. The engineer then carefully pulls the throttle-lever 51, which opens the throttle-valve 88 and admits steam into the stand-pipe 87. The throttle-valve which closes this stand-pipe is a double-seated poppit-valve formed of two flat circular pieces joined by a stem, one piece being smaller than the other so that it can pass through the upper hole but close the lower one. When the throttle-valve is moved, steam passes in above and below the valve. This arrangement makes a partly balanced valve which is easily moved. Steam passes through the stand-pipe 87 into the dry-pipe 86, thence through the branch pipe 85 in the smoke-box seen in Plate C to the steam-pipes 84, which lead it through the cylinder saddle into the steam-chests 66, 33, 33'. The openings where the steam-pipes are jointed upon the saddle are marked 84 in Plate B. In Plate A, the steam-chest 66 is represented with the valve 33 uncovering the forward port, through which the steam passes into the cylinder 1, pushing the piston 64 towards the back head. This movement is imparted through the piston-rod 65 and main rod 3 to the crank-pin 5, which turns the driving-wheels. The crank-pin is seen on the lower quarter. The left-hand side of this engine is shown. As the cranks are set at right angles to each other with the right-hand crank leading, the right-hand crank on this engine would now be on the back center.

It will be seen that the back end of the cylinder is open to the exhaust, as the escaping steam is free to pass through the port shown white up to the cavity under the valve 33 and thence into the opening of the exhaust-pipe. When the piston moves a little farther towards the back head, the valve will close the back port and open the front one to the exhaust, letting the steam in the front end of the cylinder escape. The parts can be seen more clearly in Plate D. If a drawing of the cylinder be made and patterns of the piston and valve be cut out of thick paper, they can be moved so that a student can obtain a clear idea of how the steam gets into and out of the cylinder.

#### ESCAPE OF EXHAUST STEAM.

Returning to Plate B: When the steam passes into the exhaust passage under the valve, it goes through a cavity in the saddle and emerges at 81 into the exhaust pipe 80, finally escaping at the nozzle 81 and passing to the atmosphere through the stack 25. As each puff passes through the stack it exerts a sort of pumping action on the smoke-box, tending to create a vacuum. This draws the fire-gases rapidly through the tubes and creates the forced draft on the fire required for rapid steam-making. The amount of vacuum created is controlled to some extent by the diameter of the nozzle. If the nozzle is small the steam escapes with increased rapidity, thereby tending to increase the pull on the fire.

#### DRAFT ARRANGEMENTS.

The locomotive shown has an extension smoke-box the purpose of which is to arrest sparks. Set at an

angle in front of the tube openings there is a plate 82 called the diaphragm. The object of this plate is to regulate the draft through the different rows of flues. When the gases from the fire, which tend to fly upwards, are not controlled in their movement, there is a rush through the upper rows of tubes, and the lower ones do not do their share of steam-making. The diaphragm plate partly obstructs the upper tubes, and if it is set right makes the flow of gases uniform. The petticoat-pipe performs similar functions where it is used. When the sparks pass through the tubes they strike the diaphragm and are projected forward in the extension and lie undisturbed away from the direct line of draft, which is strongest below the smoke-stack. A netting marked 83 83 83 helps to prevent the sparks from being drawn out of the smoke-box. There are various ways of arranging the netting, and it is generally put in to give as much area as possible.

## NAMES OF PARTS.

The names of nearly all the parts of the locomotive may be learned by finding the numbers in the first three plates and identifying them by means of the following list :

1. Cylinders.
2. Main driving-axle.
3. Main rod.
4. Side rod.
5. Main crank-pin.
6. Truck-wheels.

7. Main driving-wheels.
8. Back driving or trailing wheels.
9. Fire-box.
10. Expansion braces.
11. Eccentrics.
12. Eccentric-rods.
13. Link.
14. Rocker.
15. Link-hanger.
16. Horizontal arm of lifting-shaft.
17. Lifting, or tumbling-shaft.
18. Upright arm of lifting-shaft.
19. Reach-rod.
20. )
21. { Reversing-lever.
22. }
23. Barrel, or waist of boiler.
24. Smoke-box.
25. Chimney or smoke-stack.
26. Water spaces.
27. Grate.
28. Furnace-door.
29. Ash-pan.
30. Front ash-pan damper.
31. Back ash-pan damper.
32. Frames.
33. Main valve.
34. Valve-stem.
35. Head-light.
36. Head-light reflector.
37. Head-light lamp.
38. Pilot.

39. Sand-box.
40. Sand-pipes.
41. Bell.
42. Dome.
43. Cab.
44. Safety-valve.
45. Safety-valve lever.
46. Whistle.
47. Whistle-lever.
48. Draw-bar.
49. Coupling-pin.
50. Safety-chains.
51. Throttle-lever.
52. Injector.
53. Injector steam-pipe.
54. Injector feed-pipe.
55. Injector check-valve.
56. Running-board.
57. Hand-rail.
58. Equalizing-lever.
59. Driving-springs.
60. Counterbalance weights.
61. Driving-wheel guard.
62. Guide-bar.
63. Cross-head.
64. Piston.
65. Piston-rod.
66. Steam-chest.
67. Rubbing-plate for balanced valve.
68. Steam-chest relief-valve.
69. Hopper of extension smoke-box.
70. Smoke-box door.

71. Cylinder-cocks.
72. Cylinder-cock lever.
73. Cylinder-cock shaft.
74. Truck-spring.
75. Truck-frame.
76. Truck equalizing-lever.
77. Truck wheel-guard.
78. Truck check-chain.
79. Push-bar.
80. Exhaust-pipes.
81. Exhaust-nozzle.
82. Diaphragm.
83. Wire-netting.
84. Steam-pipe.
85. T-pipe.
86. Dry-pipe.
87. Throttle-pipe.
88. Throttle-valve.
89. Throttle-stem.
90. Throttle bell-crank.
91. Steam-gauge.
92. Steam-gauge lamp.
93. Whistle-lever.
94. Gauge-cocks.
95. Foot-board.
96. Truck center-bearing.
97. Truck center-plate.
98. Truck center-pin.
99. Whistle-shaft.
100. Suction-pipes.
101. Foot-steps of cab.
102. Hand-holds of cab.

- 103. Front door of cab.
- 104. Water-gauge.
- 105. Stand for oil-cans.
- 106. Drip for gauge-cocks.
- 107. Injector-valve.
- 108. Oil-cup for oiling main valves.
- 109. Handle for opening valves in sand-box.
- 110. Handle for opening front damper.
- 111. Bell-crank for opening front damper.
- 112. Rod for opening front damper.
- 113. Mud-plugs.

CYLINDER AND STEAM-CHEST.

The leading details of the locomotive's mechanism may be more clearly studied from succeeding plates.

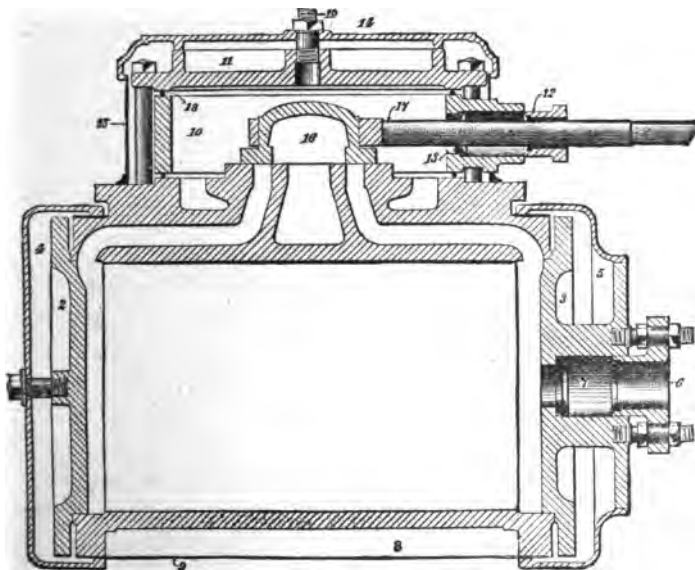

PLATE D



Plate D gives a cross-section of the cylinder and steam-chest. The principal parts are;

1. Cylinder.
2. Front cylinder-head.
3. Back cylinder-head.
4. Front casing-cover.
5. Back casing-cover.
6. Cylinder-gland.
7. Cylinder-gland packing.
8. Wood-lagging.
9. Casing.
10. Steam-chest.
11. Steam chest cover.
12. Steam-chest packing-gland.
13. Gland-ring.
14. Steam-chest casing.
15. Side of chest-casing.
16. Slide-valve.
17. Valve-yoke.
18. Steam-chest joint.
19. Oil-pipe stem.

#### PISTONS.

The piston which works in the cylinder is shown in enlarged form in Plate E. The purpose of the piston-head is to fill the cylinder bore tight enough to prevent steam blowing through between the walls of the cylinder and the piston-head, and yet be loose enough to move freely with as little friction as possible. There are various forms of piston-heads, and three kinds are shown in Plate E. Figure 1 is what is known as a solid head with two grooves round the outside into

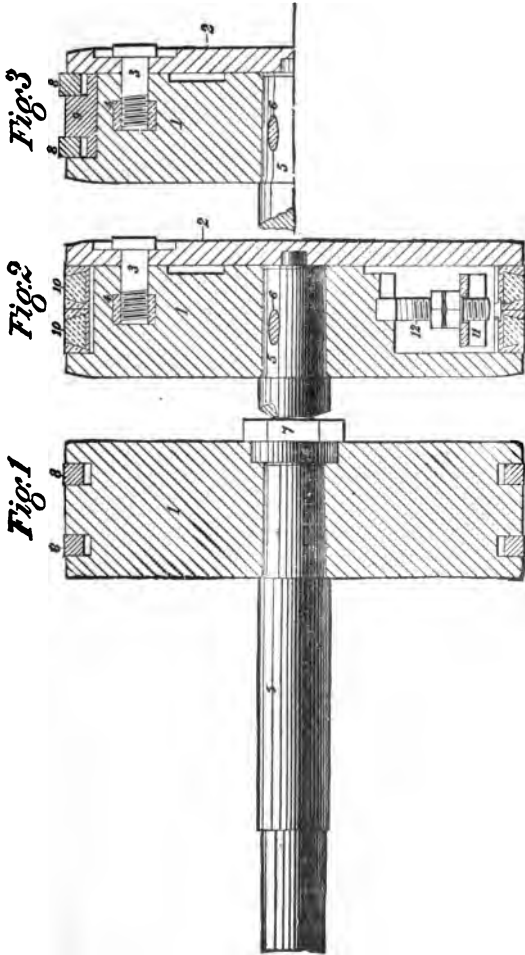

PLATE E.

which packing-rings are sprung in. Packing-rings are made of a good quality of cast-iron turned a little larger than the bore of the cylinder, and a piece cut out which permits the ring to be compressed when the piston is put into the cylinder. The rings then press the sides of the cylinder and soon form a steam-tight connection.

In Figure 2 a piston-head is shown with what is known as spring packing. The packing-rings are not made to spring, but are kept up to the cylinder-walls by separate small springs secured inside the body of the piston-head and held in tension by a stud.

Figure 3 illustrates the most common form of piston in use. The packing-rings are made with spring to them as in Figure 1, but they are carried on T-ring or bull-ring 9, which fits on the piston-spider and is held in place by the follower-plate 2.

The piston consists of the following parts:

1. Head.
2. Follower-plate.
3. Follower-bolts.
4. Follower-bolt socket.
5. Piston-rod.
6. Rod key-way.
7. Piston-rod nut.
8. Packing-rings (cast-iron).
9. Bull-ring.
10. Composite packing-rings
11. Packing-spring.
12. Spring stud and nuts.

## LINK MOTION.

Plate F, gives a very clear illustration of the link motion and its connections on the right-hand side of a Baldwin locomotive as they appear when the piston is on the forward center, and the engine is in full gear forward.

The principal parts shown are :

1. Axle.
2. Eccentric.
3. Forward half of eccentric-strap.
4. Back half of eccentric-strap.
5. Eccentric-rod (forward motion).
6. Eccentric-rod (backward motion).
7. Expansion link, back half.
8. Expansion link, front half.
9. Expansion-link filling-block.
10. Expansion-link saddle.
11. Expansion-link sliding-block.
12. Link-hanger.
13. Tumbling-shaft.
14. Counterbalance-spring.
15. Tumbling-shaft bracket.
16. Reach-rod.
17. Upper rocker-arm.
18. Rocker-box.
19. Valve-rod.

## RUNNING GEAR.

Plates G, H, I and J illustrate details of the frames, springs and equalizers, the arrangement of which requires to be carefully studied by those who are con-

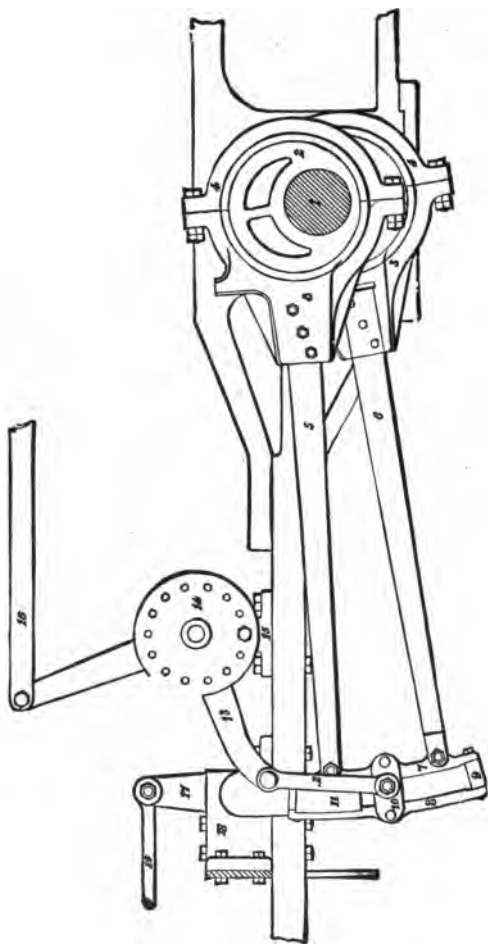

PLATE F.

nected with the running of locomotives, for a great part of the failures that happen to modern locomotives arise from accidents to some part of the running gear.

By referring back to Plate B, it will be seen that the frames, driving-wheels, and truck with their minor parts form a carriage which carries the boiler and cylinders. When this carriage is properly designed we have a good riding locomotive. To bring this about the whole of the running gear, as this part of the engine is called, must work harmoniously together. Pressing upon the upper half of the different axle-journals are bearings of brass or some other soft metal on which the weight of the engine rests. The bearing is in an axle-box which is made strong enough to protect the brass bearing and to withstand the shocks of the hard service. The driving axle-boxes are held firm in oblong formations on the frames called jaws, and secured so that the box can rise and fall freely a certain distance. On the top of the axle-box and spanning the frame is a casting called a stirrup on which the driving-spring rests. On one end hangers connect the spring to the frame, taking their part in holding up the whole of the weight resting on the wheels, and on the other end connecting with the equalizing beam which tends to transmit any severe shock over all the connecting wheels.

In Plate G, class *C* is the frame of an eight-wheel engine, class *D* is the frame of a mogul engine, and class *E* is the frame of a consolidation engine.

The principal parts are :

1. Top rail of frame and pedestals.
2. Front rail of frame.
3. Front top of mogul and consolidation frame.

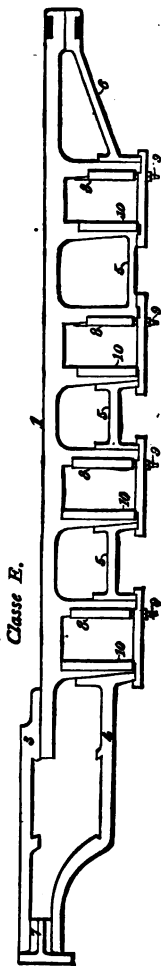
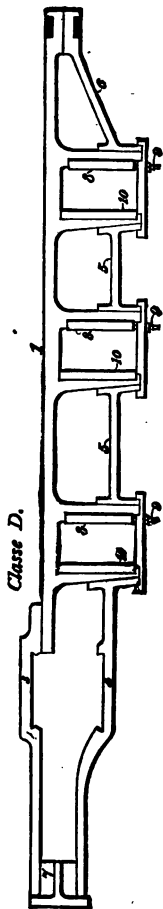
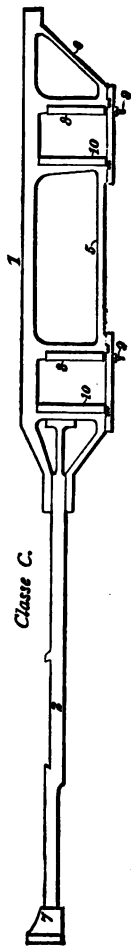

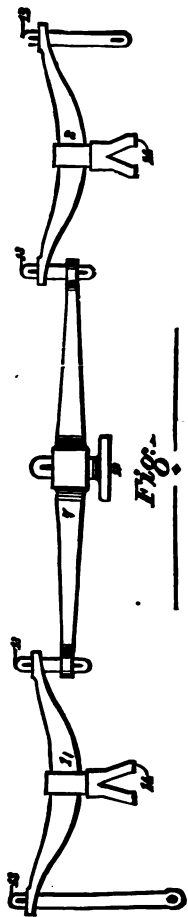

Fig. 1



Fig. 2

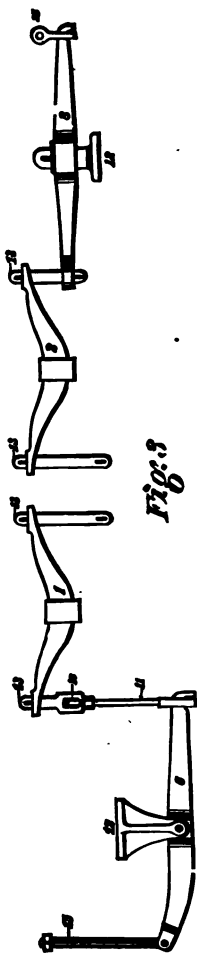

Fig. 3

PLATE H.



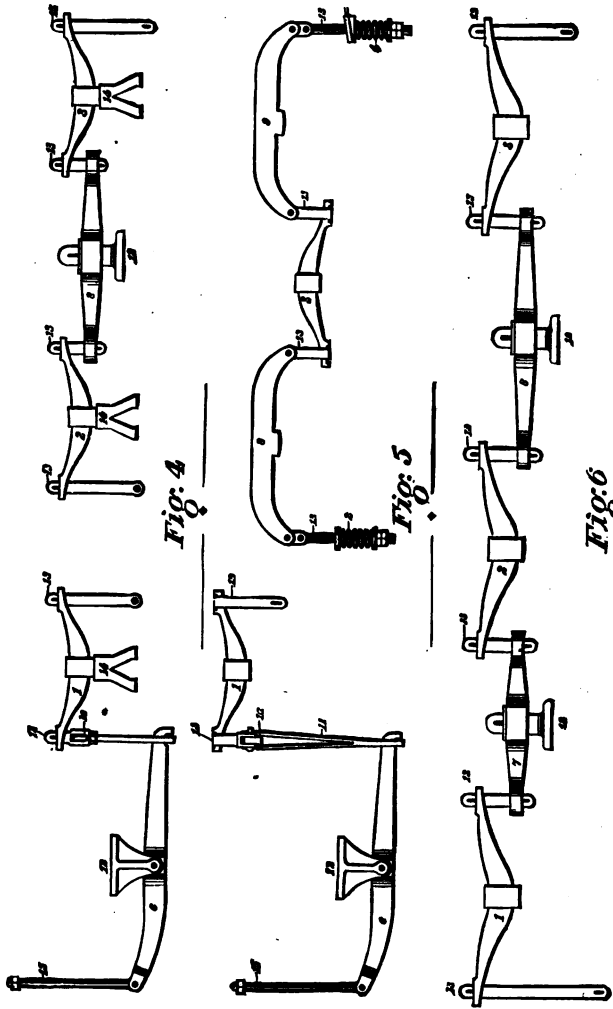

Fig. 6  
PLATE I.

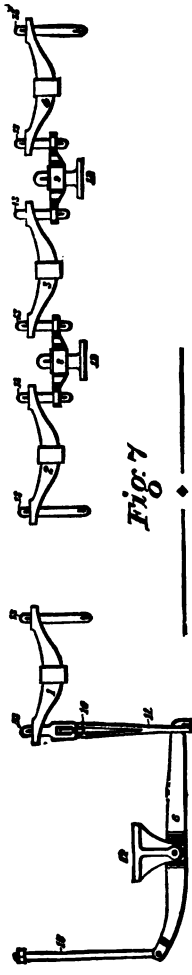

Fig. 7

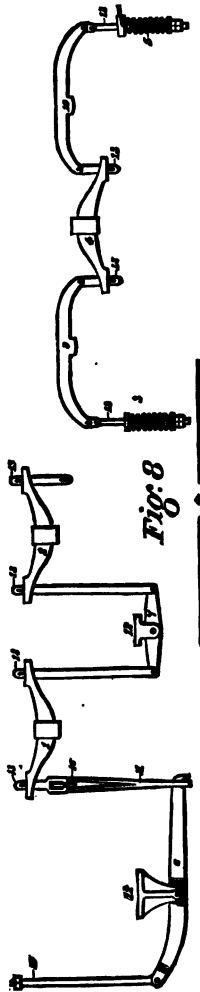

Fig. 8

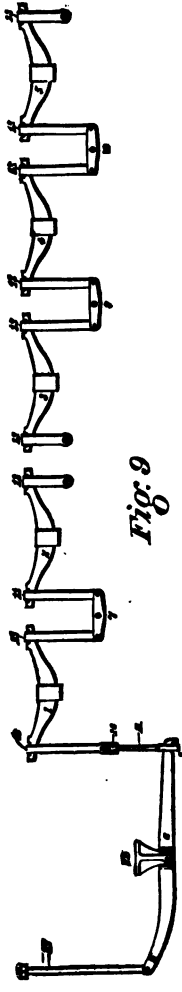

Fig. 9

PLATE J.

4. Bottom of mogul and consolidation frame.
5. Middle brace.
6. Back brace.
7. Buffer-block.
8. Pedestal-wedge.
9. Wedge-bolt.
10. Pedestal-shoe.

Above 9 is the pedestal-binder, the figure for which has been omitted.

The principal arrangements shown in Plates H, I and J are: Figure 1 is spring and equalizer arrangement of an ordinary eight-wheel engine with both springs on top of axle-boxes. Figure 2 shows a spring arrangement for an eight-wheel locomotive where only one spring can be placed above the frames. Figures 3 to 9 show a variety of arrangements for springs and equalizers that embrace nearly all requirements.

The following parts are shown :

1. Forward driving-spring.
2. Second driving-spring.
3. Third driving-spring.
4. Fourth driving-spring.
5. Fifth driving-spring.
6. Forward-truck equalizer.
- 7, 8, 9, 10. Different kinds of equalizers.
11. Equalizer-link.
12. Equalizer-fulcrum.
13. Spring-hanger.
14. Spring-stirrup.
15. Truck center-pin.
16. Transverse equalizer.

In Plate K are shown the form of construction of a

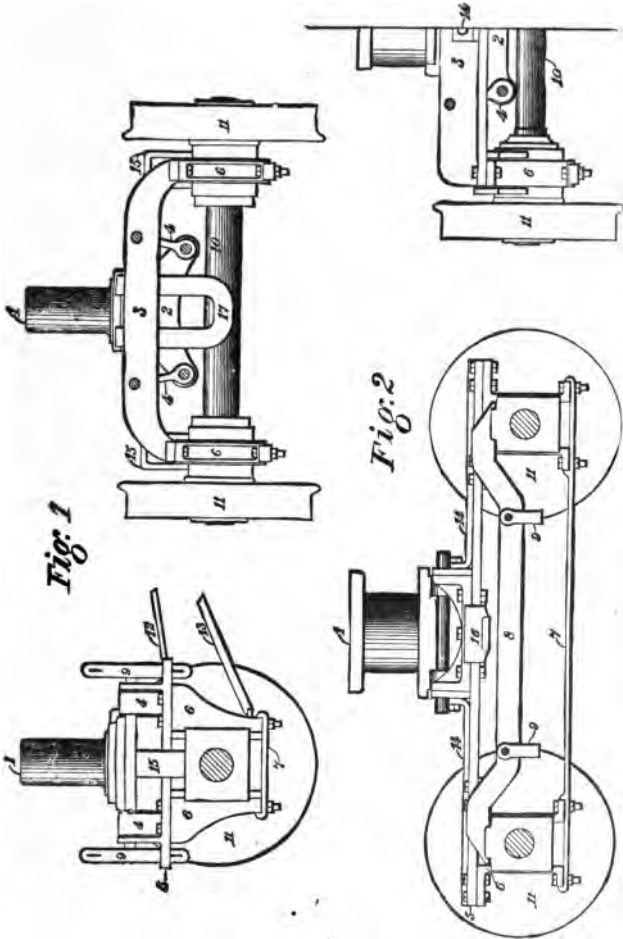

*Fig: 1*

*Fig: 2*

PLATE K.

four-wheel engine-truck and of a two-wheel pony-truck.

The principal parts are : .

1. Center-pin.
2. Swing-bolster.
3. Swing-bolster cross-tie.
4. Swing-bolster hanger.
5. Truck-frame.
6. Truck-pedestal.
7. Truck binder-brace.
8. Equalizer.
9. Spring-hanger.
10. Axle.
11. Wheel.
12. Radius bar.
13. Radius-bar brace.
14. Truck-frame.
15. Spring-stirrup.
16. Spring-seat.
17. Safety-strap.

# LOCOMOTIVE ENGINE RUNNING.

---

## CHAPTER I.

### ENGINEERS AND THEIR DUTIES.

#### ATTRIBUTES THAT MAKE A GOOD ENGINEER.

THE locomotive engine which reaches nearest perfection, is one which performs the greatest amount of work at the least cost for fuel, lubricants, wear and tear of machinery and of the track traversed : the nearest approach to perfection in an engineer, is the man who can work the engine so as to develop its best capabilities at the least cost. Poets are said to be born, not made. The same may be said of engineers. One man may have charge of an engine for only a few months, and yet exhibit thorough knowledge of his business, displaying sagacity resembling instinct concerning the treatment necessary to secure the best performance from his engine : another man, who appears equally intelligent in matters not pertaining to the locomotive, never develops a thorough understanding of the machine.

There are few lines of work where the faculty of concentrating the mind to the work on hand is so valuable as in that of running a locomotive. A man may be highly intelligent and be well endowed with general knowledge, but on a locomotive he will make a failure, unless his whole attention while on duty, is devoted to the duties of taking the locomotive and train over the division safely on time. The man, who lets outside hobbies or interests take much of his time while running a locomotive, is likely to get into many scrapes.

#### HOW ENGINEERING KNOWLEDGE AND SKILL ARE ACQUIRED.

A man who possesses the natural gifts necessary for the making of a good engineer, will advance more rapidly in acquiring mastery of the business than does one whom Nature intended for a ditcher. But there is no royal road to the knowledge requisite for making a first-class engineer. The capability of handling an engine can be acquired by a few months' practice. Opening the throttle, and moving the reverse lever, require but scanty skill ; there is no great accomplishment in being able to pack a gland, or tighten up a loose nut ; but the magazine of practical knowledge, which enables an engineer to meet every emergency with calmness and promptitude, is obtained only by years of experience on the footboard, and by assiduous observation while there.

**PUBLIC INTEREST IN LOCOMOTIVE ENGINEERS.**

Ever since the incipency of the railroad system, a close interest has been manifested by the general public in the character and capabilities of locomotive engineers. This is natural, for no other class of men hold the safe-keeping of so much life and property in their hands.

**IGNORANCE VERSUS KNOWLEDGE.**

Two leading pioneers of railway progress in Europe took diametrically opposite views of the intellectual qualities best calculated to make a good engineer. George Stephenson preferred intelligent men, well educated and read up in mechanical and physical science ; Brunel recommended illiterate men for taking charge of engines, on the novel hypothesis that, having nothing else in their heads, there would be abundant room for the acquirement of knowledge respecting their work. In every test of skill, the intelligent men proved victors.

**ILLITERATE ENGINEERS NOT WANTED IN AMERICA.**

No demand for illiterate or ignorant engineers has ever arisen in America. Many men who have spent an important portion of their lives on the footboard have risen to grace the highest ranks of the mechanical and social world. The pioneer engines, which demonstrated the successful working of locomotive power, were run by some of the most accomplished mechanical engineers in the country. As an engine



adapted to the work it has to perform, the American locomotive is recognized to have always kept ahead of its compeers in other parts of the world. No inconsiderable part of this superiority is due to the fact, that nearly all the master mechanics who control the designing of our locomotives have had experience in running them, and thereby understand exactly the qualities most needed for the work to be done.

#### GROWING IMPORTANCE OF ENGINEERS' DUTIES.

The safe and punctual operation of our railroads has always depended to a great extent, and always will depend, upon the discriminating care and judgment of the engineer. Every year sees the introduction of new appliances for the purpose of increasing the safety of train operating, but no automatic appliances will ever enable a man to run a locomotive safely if he is deficient in judgment, care, and intelligence. The increasing amount of train mechanism every year imposes new responsibilities upon the locomotive engineers. The tendency is to require the engineer to understand not only everything about the locomotive, but every detail of air-brake mechanism, and also that of train signals, heating apparatus, lighting appliances and every other train attachment. He is gradually coming to fill on a train the position that a chief engineer holds on a steamer.

#### INDIVIDUALITY OF AMERICAN ENGINEERS.

Writing on the fitness of various railroad employes for their duties, that eminent authority, Ex-Railroad

Commissioner Charles F. Adams says: "In discussing and comparing the appliances used in the practical operating of railroads in different countries, there is one element, however, which can never be left out of the account. The intelligence, quickness of perception, and capacity for taking care of themselves,—that combination of qualities, which, taken together, constitute individuality, and adaptability to circumstances,—vary greatly among the railroad employés of different countries. The American locomotive engineer, as he is called, is especially gifted in this way. He can be relied on to take care of himself and his train under circumstances which in other countries would be thought to insure disaster."

#### NECESSITY FOR CLASS IMPROVEMENT.

While American locomotive engineers can confidently invite comparison between their own mechanical and intellectual attainments and those of their compeers in any nation under the sun, there still remains ample room for improvement. If they are not advancing, they are retrograding. The engineer who looks back to companions of a generation ago, and says that we know as much as they did, but no more, implies the assertion that his class is going backward. On very few roads, and in but rare instances, can this grave charge be made, that the engineers are falling behind in the intellectual race. On the contrary, there are signs all around us of substantial work in the cause of intellectual and moral advancement.

THE SKILL OF ENGINEERS INFLUENCES OPERATING EXPENSES.

No class of railroad-men affects the expenses of operating so directly as engineers do. The daily wages paid to an engineer is a trifling sum compared to the amount he can save or waste by good or bad management of his engine. Fuel wasted, lubricants thrown away, supplies destroyed, and machinery abused, leading to extravagant running repairs, make up a long bill by the end of each month, where enginemen are incompetent. Every man with any spark of manliness in his breast will strive to become master of his work ; and, stirred by this ambition, he will avoid wasting the material of his employer just as zealously as if the stores were his own property ; and only such men deserve a position on the footboard.

The day has passed away when an engineer was regarded as perfectly competent so long as he could take his train over the road on time. Nowadays a man must get the train along on schedule time to be tolerated at all, and he is not considered a first-class engineer unless he possesses the knowledge which enables him to take the greatest amount of work out of the engine with the least possible expense. To accomplish such results, a thorough acquaintance with all details of the engine is essential, so that the entire machine may be operated as a harmonious unit, without jar or pound ; the various methods of economizing heat must be intimately understood, and the laws which

govern combustion should be well known so far as they apply to the management of the fire.

#### METHODS OF SELF-IMPROVEMENT.

To obtain this knowledge, which gives power, and directly increases a man's intrinsic value, young engineers and aspiring firemen must devote a portion of their leisure time to the form of self-improvement relating to the locomotive. Socrates, a sagacious old Greek philosopher, believed that the easiest way to obtain knowledge was by persistently asking questions. Young engineers can turn this system to good account. Never feel ashamed to ask for information where it is needed, and do not imagine that a man has reached the limit of mechanical knowledge when he knows how to open and shut the throttle-valve. The more a man progresses in studying out the philosophy of the locomotive and its economical operation the more he gets convinced of his own limited knowledge. A young engineer who seeks for knowledge by questioning his elders must not feel discouraged at a rebuff. Men who refuse to answer civilly questions asked by juniors searching for information are generally in the dark themselves, and attempt by rudeness to conceal their own ignorance.

#### OBSERVING SHOP OPERATIONS.

The system in vogue in most of our States, especially in the West, of taking on men for firemen who have received no previous mechanical training leaves a wide field open for engineering instruction. Such men can-

not spend too much time watching the operations going on in repair-shops; every detail of round-house work should be closely observed; the various parts of the great machine they are learning to manage should be studied in detail. No operation of repairs is too trifling to receive strict attention. Where the machinists are examining piston-packing, facing valves, reducing rod-brasses, or lining down wedges, the ambitious novice will, by close watching of the work, obtain knowledge of the most useful kind. Looking on will not teach him how to do the work, but interesting himself in the procedure is a long step in the direction of learning. Repairing of pumps and injectors is interesting work, full of instructive points which may prove invaluable on the road. The rough work performed by the men who change truck-wheels, put new brasses in oil-boxes, and replace broken springs is worthy of close attention; for it is just such work that enginemmen are most likely to be called upon to perform on the road in cases of accident. To obtain a thorough insight into the working of the locomotive, no detail of its construction is too trifling for attention. The unison of the aggregate machine depends upon the harmonious adjustment of the various parts; and, unless a man understands the connection of the details, he is never likely to become skillful in detecting derangements.

#### WHERE IGNORANCE WAS RUIN.

I knew a case where the neglect to learn how minor work about the engine was done proved fatal to the

prospects of a young engineer. A new engine-truck box had been adopted shortly before he went running; and, although he had often seen the cellar taken down by the round-house men when they were packing the trucks, he never paid close attention to how it was done. As the new plan was a radical change from the old practice, taking down the new cellar was a little puzzling at first to a man who did not know how to do it. One day this young engineer took out an engine with the new kind of truck, and a journal got running hot. He crept under the truck among snow and slush to take the cellar down for packing; but he struggled half an hour over it, and could not get the thing down. Then the conductor came along, to see what was the matter; and, being posted on such work, he perceived that the young engineer did not know how to take the cellar out of the box. The conductor helped the engineer to do a job he should have needed no assistance with. The story was presently carried to headquarters with additions, and was the means of returning the young engineer to the left-hand side.

#### PREJUDICE AGAINST STUDYING BOOKS.

There is a silly prejudice in some quarters against engineers applying to books for information respecting their engines. Engineers are numerous who boast noisily that all their knowledge is derived from actual experience, and they despise theorists who study books, drawings, or models in acquiring particulars concerning the construction or operation of the locomotive parts. Such men have nothing to boast of.

They never learn much, because ignorant egotism keeps them blind. They keep the ranks of the mere stopper and starter well filled.

#### THE KIND OF KNOWLEDGE GAINED FROM BOOKS.

The books on mechanical practice which these ultra-practical men despise contain in condensed form the experience and discoveries that have been gleaned from the hardest workers and thinkers of past ages. The product of long years of toilful experiment, where intense thought has furrowed expansive brows, and weary watching has whitened raven locks, is often recorded on a few pages. A mechanical fact which an experimenter has spent years in discovering and elucidating can be learned and tested by a student in as many hours. The man who despises book-knowledge relating to any calling or profession rejects the wisdom begotten of former recorded labor.

The study of good books relating to the locomotive will teach the young engineer many things about his engine that can be verified by practice. If anything in a book induces an engineer to think for himself, and sets him to observing and investigating, it is certain to do him good.

#### MODELS AND CROSS-SECTIONS.

A highly instructive and interesting means of self-instruction that can be reached by most ambitious engineers and firemen is the study of models and cut cross-sections of locomotive mechanism. Many division brotherhood rooms used by engineers and fire-

men have models and cross-sections of valve gear, lubricators, brake mechanism, etc. These appliances offer invaluable aid to men anxious to learn about the working of the parts they represent, and constant use ought to be made of them.

Valve gears are a favorite study with young engineers, and information about their arrangement and action can be studied to the greatest advantage by the aid of a model. The chapters on valve motion, farther on in this book, are made as plain as simple words and clear wood-cuts can make them; but the subjects treated will be much easier understood if they are studied with a model at hand for reference. Two or three studious engineers or firemen can give great help to each other by forming a class to study a model together by the aid of the chapters on valve gear. When that part is mastered, they will be likely to study the Westinghouse air-brake and other parts in the same way. The union of two or three together for the purpose of mutual study yields a form of strength that is certain to have a sustaining influence throughout the life of those participating.





## CHAPTER II.

### HOW LOCOMOTIVE ENGINEERS ARE MADE.

#### RELIABLE MEN NEEDED TO RUN LOCOMOTIVES.

Locomotive engine running is one of the most modern of trades, consequently its acquirement has not been controlled by the exact methods associated with ancient guild apprenticeships. Nevertheless, graduates to this business do not take charge of the iron horse without the full meed of experience and skill requisite for performing their duties successfully. The man who runs a locomotive engine on our crowded railroads has so much valuable property, directly and indirectly, under his care, so much of life and limb depending upon his skill and ability, that railroad companies are not likely to intrust the position to those with a suspicion of incompetency resting upon them.

#### DIFFICULTIES OF RUNNING LOCOMOTIVES AT NIGHT, AND DURING BAD WEATHER.

In the matter of speed alone there is much to learn before a man can safely run a locomotive. During daylight a novice will generally be half out in estimating speed; and his judgment is merely wild gues-

work, regulated more by the condition of the track than by the velocity his train is reaching. On a smooth piece of track he thinks he is making twenty-five miles an hour, when forty miles is about the correct speed: then he strikes a rough portion of the road-bed, and concludes he is tearing along at thirty miles an hour, when he is scarcely reaching twenty miles; since the first lurchy spot made him shut off twenty per cent of the steam. At night the case is much worse, especially when the weather proves unfavorable. On a wild, stormy night the accumulated experience of years on the footboard, which trains a man to judge of speed by sound of the revolving wheels, and to locate his position between stations from a tree, a shrub, a protruding bank, or any other trifling object that would pass unnoticed by a less cultivated eye, is all needed to aid an engineer in working along with unvaried speed without jolt or tumult. On such a night a man strange to the business cannot work a locomotive and exercise proper control over its movements. He may place the reverse-lever latch in a certain notch, and keep the steam on; he can regulate the injector after a fashion, and watch that the water shall not get too low in the boiler; he can shut off in good season while approaching stations, and blunder into each depot by repeatedly applying steam; but he exerts no control over the train, knows nothing of what the engine is doing, and is constantly liable to break the train in two. A diagram of his speed would fluctuate as irregularly as the profile lines of a bluffy country. This is where a machinist's skill

does not apply to locomotive-running until it is supplemented by an intimate knowledge of speed, of facility at handling a train and keeping the couplings intact, and of insight into the best methods of economizing steam.

These are essentials which every man should possess before he is put in charge of a locomotive on the road. The great fund of practical knowledge which stamps the first-class engineer is amassed by general labor during years of vigilant observation on the foot-board, amidst many changes of fair and foul weather.

As passing through the occupation of fireman was the only way men could obtain practical knowledge of engine-running before taking charge, railroad officials all over the world gradually fell into the way of regarding that as the proper channel for men to traverse before reaching the right-hand side of the locomotive.

#### KIND OF MEN TO BE CHOSEN AS FIREMEN.

As the pay for firemen rules moderately good, even when compared with other skilled labor; and as the higher position of engineer looms like a beacon not far ahead,—there is always a liberal choice of good men to begin work as firemen. Most railroad companies recognize the importance of exercising judgment and discretion in selecting the men who are to run as their future engineers. Sobriety, industry, and intelligence are essential attributes in a fireman who is going to prove a success in his calling. Lack in any one of these qualities will quickly prove fatal to a fireman's prospects of advancement. Sobriety is of

the first importance, because a man who is not strictly temperate should not be tolerated for a moment about a locomotive, since he is a source of danger to himself and others; industry is needed to lighten the burden of a fireman's duties, for oftentimes they are arduous beyond the conception of strangers; and wanting in the third quality, intelligence, a man can never be a good fireman in the wide sense of the word, since one deficient in mental tact never rises higher than a human machine. An intelligent fireman may be ignorant of the scientific nomenclature relating to combustion, but he will be perfectly familiar with all the practical phenomena connected with the economical generation of steam. Such a man does not imagine that he has reached the limit of locomotive knowledge when he understands how to keep an engine hot and can shine up the jacket. Every trip reveals something new about his art, every day opens his vision to strange facts about the wonderful machine he is learning to manage. And so, week by week, he goes on his way, attending cheerfully to his duties, and accumulating the knowledge that will eventually make him a first-class locomotive engineer.

#### FIRST TRIPS.

A youth entirely unacquainted with all the operations which a fireman is called upon to perform finds the first trip a terribly arduous ordeal, even with some previous experience of railroad work. When his first trip introduces him to the locomotive and to railroad

life at the same time, the day is certain to be a record of personal tribulation. To ride for ten or twelve hours on an engine for the first time, standing on one's feet, and subject to the shaking motion, is intensely tiresome, even if a man has no work to do. But when he has to ride during that period, and in addition has to shovel six or eight tons of coal, most of which has to be handled twice, the job proves no sinecure. Then, the posture of his body while doing work is new; he is expected and required to pitch coal upon certain exact spots, through a small door, while the engine is swinging about so that he can scarcely keep his feet; his hands get blistered with the shovel, and his eyes grow dazzled from the resplendent light of the fire. Then come the additional side duties of taking water, shaking the grates, cleaning the ash-pan, or even the fire, where bad coal is used, filling oil-cans, and trimming lamps, to say nothing of polishing and keeping things clean and tidy. By the time all these duties are attended to the young fireman does not find a great deal of leisure to admire the passing scenery.

#### POPULAR MISCONCEPTION OF A FIREMAN'S DUTIES.

A great many idle young fellows, ignorant of railroad affairs, imagine that a fireman's principal work consists in ringing the bell, and showing himself off conspicuously in coming into stations. They look upon the business as being of the heroic kind, and strive to get taken on as firemen. If a youth of this kind happens to succeed, and starts out on a run of

one hundred and fifty miles with every car a heavy engine will pull stuck on behind, his visions of having reached something easy are quickly dispelled.

Like nearly every other occupation, that of fireman has its drawbacks to counterbalance its advantages; and the drawbacks weigh heaviest during the first ten days. The man who enters the business under the delusion that he can lead a life of semi-idleness must change his views, or he will prove a failure. The man who becomes a fireman with a spirit ready and willing to overcome all difficulties, with a cheerful determination to do his duty with all his might, is certain of success; and to such a man the work becomes easy after a few weeks' practice.

#### LEARNING FIREMEN'S DUTIES.

Practice, combined with intelligent observation, gradually makes a man familiar with the best styles of firing, as adapted to all varieties of engines; and he gets to understand intimately all the qualities of coal to be met with, good, bad, and indifferent. As his experience widens, his fire management is regulated to accord with the kind of coal on hand, the steaming properties of the engine, the weight of the train, the character of the road and of the weather. Firing, with all the details connected with it, is the central figure of his work, the object of pre-eminent concern; but a good man does not allow this to prevent him from attending regularly and exactly to his remaining routine duties.

## A GOOD FIREMAN MAKES A GOOD ENGINEER.

There is a familiar adage among railroad men, that a good fireman is certain to make a good engineer; and it rarely fails to come out true. To hear some firemen of three months' standing talk, a stranger might conclude that they knew more about engine-running than the oldest engineer in the district. These are not the good firemen. Good firemen learn their own business with the humility born of earnestness, and they do not undertake to instruct others in matters beyond their own knowledge. It is the man who goes into the heart of a subject, who understands how much there is to learn, and is therefore modest in parading his own acquirements, that succeeds.

## LEARNING AN ENGINEER'S DUTIES.

When a fireman has mastered his duties sufficiently to keep them going smoothly, he begins to find time for watching the operations of the engineer. He notes how the boiler is fed; and, upon his knowledge of the engineer's practice in this respect, much of his firing is regulated. The different methods of using the steam by engineers, so that trains can be taken over the road with the least expenditure of coal, are engraven upon the memory of the observant fireman. Many of the acquirements which commend a good fireman for promotion are learned by imperceptible degrees,—the knowledge of speed, for instance, which enables a man to tell how fast a train is running on all kinds of track, and under all conditions of weather.

There would be no use in one strange to train service going out for a few runs to learn speed. He might learn nearly all other requisites of engine-running before he was able to judge within ten miles of how fast the train was going under adverse circumstances. The same may be said of the sound which indicates how an engine is working. It requires an experienced ear to detect the false note which indicates that something is wrong. Amidst the mingled sounds produced by an engine and train hammering over a steel track, the novice hears nothing but a medley of confused noises, strange and meaningless as are the harmonies of an opera to an untutored savage. But the trained ear of an engineer can distinguish a strange sound amidst all the tumult of thundering exhaust, screaming steam, and clashing steel, as readily as an accomplished musician can detect a false note in a many-voiced chorus. Upon this ability to detect growing defects which pave the way to disaster depends much of an engineer's chances of success in his calling. This kind of skill is not obtained by a few weeks' industry: it is the gradual accumulation of months and years of patient labor.

#### LEARNING TO KEEP THE LOCOMOTIVE IN RUNNING ORDER.

As his acquaintance with the handling and ordinary working of the locomotive extends, the aspiring fireman learns all about the packing of glands, and how they should be kept so as to run to the best advan-



tage: he displays an active interest in everything relating to lubrication, from the packing of a box-cellar to the regulating of a rod-cup. When the engineer is round keying up rods, or doing other necessary work about his engine, the ambitious fireman should give a helping hand, and thereby become familiar with the operations that are likely to be of service when he is required to draw upon his own resources for doing the same work.

Of late years the art of locomotive construction has been so highly developed, the amount of strain and shocks to which each working part is subjected has been so well calculated and provided against, that breakages are really very rare on roads where the motive power is kept in first-class condition. Consequently, firemen gain comparatively small insight, on the road, into the best and quickest methods of disconnecting engines, or of fixing up mishaps promptly, so that a train may not be delayed longer than is absolutely necessary. A fireman must get this information beyond the daily routine of his experience. He must search for the knowledge among those competent to give it. Persistent inquiry among the men posted on these matters; observation amidst machine-shop and round-house operations; and careful study of locomotive construction, so that a clear insight into the physiology of the machine may be obtained,—will prepare one to meet accidents, armed with the knowledge which vanquishes all difficulties. Reflecting on probable or possible mishaps, and calculating what is best to be done under all contingencies

that can be conceived, prepare a man to act promptly when a break-down occurs.

**METHODS OF PROMOTION ON OUR LEADING ROADS.**

In the method of promotion of firemen considerable diversity of practice is followed by the different railroads. On certain roads, with well-established business, and little fluctuation of traffic, firemen begin work on switch-engines, and are promoted by seniority, or by selection through the various grades of freight trains, thence to passenger service, from whence they emerge as incipient engineers. A more common practice, and one almost invariably followed in the West, is for firemen to begin as extra men, in place of firemen who are sick or lying off. From firing extra, they get advanced, if found competent and deserving, to regular engines. Then, step by step, they go ahead to the best paying runs, till their turn for being "set up" comes round. Passenger engines are not fired by any but experienced men, but the oldest firemen do not always claim passenger-runs. For learning the business of engine-running freight service is considered most valuable; and many ambitious firemen prefer the hard work of a freight engine on this account.

**NATURE OF EXAMINATION TO BE PASSED.**

When a fireman has obtained the experience that recommends him for promotion, on nearly all well-

regulated roads he is subjected to some form of examination before being put in charge of an engine. In some cases this examination is quite thorough. The tendency to require firemen to pass such an ordeal is extending, and its beneficial effect upon the men is unquestioned. The usual form of examination is, for officers connected with the locomotive department to question the candidate for promotion on matters relating to the management of the locomotive, and how he would proceed in the event of certain mishaps befalling the engine. Parties belonging to the traffic department propound questions relating to road-rules, train-rights, understanding of time-card, and so on.

A common practice among progressive railroad companies is to subject their firemen to an examination, with questions and answers similar to those given in the form of examination adopted by the Traveling Engineers' Association and published in another chapter of this book. The questions and answers are given to show to the candidate for promotion the scope of knowledge he is expected to possess. The prevailing practice in carrying on the examination is to vary the questions enough to find out that the fireman has not merely committed the words of the answer to memory without understanding the subject. A careful study of this book will give a candidate for promotion good sound knowledge of all the questions that will be asked, and will enable him to prove to the examiners that his acquaintance with the working of the locomotive is sufficient for dealing with all difficulties likely to arise.

A good practice for firemen who read this book is to note what is recommended to be done in case of accidents or emergencies and study how the recommendations could best be carried out on the locomotives they are acquainted with. Try to give a practical application of every recommendation.

## CHAPTER III.

### INSPECTION OF THE LOCOMOTIVE.

#### LOCOMOTIVE INSPECTORS.

ON well-managed railroads, where the system of pooling locomotives prevails, there is a locomotive inspector employed, whose duty it is to thoroughly examine every available point about every engine that arrives at his station, and find out what repairs are needed, and to detect the incipient defects which lead to disaster on the road. Some roads that do not practice pooling have an inspector who examines every engine. These inspectors are not employed to exempt engineers from looking over their engines, but merely to supplement their care. In some cases engineers are brought sharply to task if they overlook any important defect which is discovered by the inspector.

#### GOOD ENGINEERS INSPECT THEIR OWN ENGINES.

The engineer who has a liking for his work, and takes pride in making his engine perform its part so as to show the highest possible record, does not require the fear of an inspector behind him as an incen-

tive to properly examine his engine, and keep it in the best running-order. He recognizes the fact that upon systematic and regular inspection of the engine while at rest depend in a great measure his success as a runner and his exemption from trouble.

WHAT COMES OF NEGLECTING SYSTEMATIC  
INSPECTION OF LOCOMOTIVES.

The man who habitually neglects the business of inspecting his engine, and leaves to luck his chances of getting over the road safely, soon finds that the worst kind of luck is always overtaking him on the road. A careful man may have a run of bad luck occasionally, but the careless man meets with nothing else. Among a great many men who have failed as runners, I can recall numerous cases where carelessness about the engine was the only and direct cause which led them to failure. One of the most successful engineers that ever pulled a throttle on the Erie Railroad was asked by a young runner to what cause he attributed his extraordinary good fortune. His reply was, "I never went out without giving my engine a good inspection." This man had been running nearly half a century, and never needed to have his engine hauled to the round-house.

CONFIDENCE ON THE ROAD DERIVED FROM  
INSPECTION.

When a locomotive is thundering over a road ahead of a heavy train in which may be hundreds of human beings, the engineer ought to understand that the

safety of this freight of lives depends to a great extent upon his care and foresight. As the train rushes through darkened cuttings, spans giddy bridges, or rounds curves edged by deep chasms, no one can understand better than the engineer the importance of having every nut and bolt about the engine in good condition, and in its proper place. The consciousness that everything is right, the knowledge that a thorough inspection at the beginning of the journey proved the locomotive to be in perfect condition, give a wonderful degree of comfort and confidence to the engineer as he urges his train along at the best speed of the engine.

#### INSPECTION ON THE PIT.

Between the time of an engine's return from one trip and its preparation for another a thorough examination of all the machinery and running-gear should be made while the engine is standing over a pit. Monkey-wrench in one hand, and a torch in the other if necessary, the engineer ought to enter the pit at the head of the engine, and make the inspection systematically. The engine-truck, with all its connections, comes in for the first scrutiny. Now is the time to guard against the loss of bolts or screws, which leads to the loss of oil-box cellars on the road. This is also the proper time to examine the condition of the oil-box packing. The engineers of my acquaintance who are most successful in getting trains over the road on time attend to the packing of the truck-boxes themselves. Nothing is more annoying on the

road than hot boxes. They are a fruitful source of delay and danger, and nothing is better calculated to prevent such troubles than good packing and clear oil-holes. The shopmen who are kept for attending to this work are sometimes careless. They can hardly be expected to feel so strongly impressed with the importance of having boxes well packed as the engineer, who will be blamed for any delay. He should, therefore, know from personal inspection that the work is properly done.

When the engineer is satisfied that the truck, pilot-braces, center-castings, and all their connections are in proper condition, he passes on to the motion. His trained eye scans every bolt, nut, and key in search of defects. The eccentrics are examined, to see that set-screws and keys are all tight. Men who have wrestled over the setting of eccentrics on the road are not likely to forget this part. Eccentric-straps are another point of solicitude. A broken eccentric-strap is a very common cause of break-down, and these straps very seldom break through weakness or defect of the casting. In nearly all cases the break occurs through loss of bolts, or on account of oil-passages getting stopped up. The links are carefully gone over, then the wedges and pedestal-braces come in for an examination which brings the assurance that no bolts are missing or wedge-bolts loose. Passing along, the careful engineer finds many points that claim his attention; and when he gets through he feels comfortably certain that no trouble from that part of the engine will be experienced during the coming trip. The runners who do not follow this



practice are not aware of how much there is to be seen under a locomotive when the examination is undertaken in a comprehensive manner.

#### OUTSIDE INSPECTION.

In going round the outside of the engine the most important points for examination are the guides and the rods. Guide-bolts, rod-bolts, and keys, with the set-screws of the latter, are the minutiae most likely to give trouble if neglected. In going about the engine oiling, or for any other purpose, it is a good thing to get in the habit of searching for defects. When a man trains himself to do this, it is surprising how natural it comes to make running inspections. As he oils the eccentric-straps, he sees every bolt and nut within sight; as he drops some oil on the rods, he identifies the condition of the keys, set-screws, or bolts; while oiling the driving-boxes, the springs can be conveniently examined; and when he reaches the engine-trucks with the oil-can he is sure to be casting his searching eyes over the portions of the running-gear within sight.

#### OIL-CUPS.

The oil-cups should be carefully examined, to see that they are in good feeding order. A great many feeders have been invented, which guarantee to supply oil automatically; but I have never yet seen the cup which could long dispense with personal attention. And this does not apply to locomotives alone, but to all kinds of machinery. The worst sort of oil-cup will

perform its functions fairly in the hands of a capable man, and the most pretentious cup will soon cease to lubricate regularly if the engineer neglects it. The oil-cups should be cleaned out at regular intervals: for mud, cinders, and dust work in; and they sometimes retain glutinous matter from the oil, which forms a sticky mixture that prevents the oil from running. The eccentric-strap cups and the tops of the driving-boxes should receive similar attention.

In looking round an engine it is a good plan to watch the different oil-cups to see that they are not working loose. Many cups that are strewed over the country could be saved by a little more attention. A cup flying off a rod when an engine is running fast becomes a dangerous projectile. I have known several cases where cups went back through the cab window. I have also seen several cases where cups worked off the guides or cross-head, and got between the guides, doing serious damage. One instance was that of an engine out on the trial trip. It smashed the cross-head to pieces, and let the piston through the cylinder-head.

#### INSPECTION OF RUNNING-GEAR.

A sharp tap with a hammer on the tread of the cast-iron wheel will produce a clear, ringing sound if the wheel is in good order. The drivers can generally be effectively inspected by the eye. If oil be observed working out between the wheel and axle, attention is demanded; for the wheel may be getting loose. Moisture and dirt issuing from between the tire and wheel

indicate that the former is becoming loose, and this is a common occurrence when the tires are worn thin. When a wheel is running so that the flange is cutting itself on the rail, something is wrong, which also demands immediate attention. Oblique travel of wheels may be produced by various causes. If the axles of the driving-wheels are not secured at right angles to the frames, and parallel with each other, the wheels will run tangentially to the track, according to the inclination of the axles. Violent strains or concussions, such as result from engines jumping the track about switches, sometimes spring the frames, and twist the axle-box jaws away from their true position enough to cause cutting of flanges without disabling the engine. Tires wearing unevenly in consequence of one being harder than the other produce a similar effect. Where there are movable wedges forward and aft of the boxes, the wheels are often thrown out of square by unskillful manipulation of these wedges. Engineers running engines of this kind should leave the forward wedges alone. Sometimes the center-pin of the engine-truck gets moved from the true central position, leading the drivers toward the ditch. Diagnosing the cause of wheel-cutting is no simple matter, and it is a wise plan for engineers to allow the shopmen to devise a remedy.

#### ATTENTIONS TO THE BOILER.

On our well-regulated roads engineers are not required to inspect their boilers; as expert boiler-makers, who can readily detect a broken stay-bolt or broken brace, have to make periodical examinations. But a

prudent engineer will keep a sharp lookout for indications that show weak points about any part of the boiler or fire-box. This department cannot receive too much vigilance. A seam or stay-bolt leaking is a sign of distress, and should receive immediate attention. Leaks under the jacket should never be neglected, although they are hard to reach; for they may proceed from the beginning of a dangerous rupture. A leak starting in the boiler-head should make the engineer ascertain that none of the longitudinal braces have broken. I once had some rivet-heads on my boiler-head start leaking, and presently the water-glass broke. After shutting off the cocks, I found that the boiler-head was bulged out. I reduced the pressure on the boiler as quickly as possible. When the boiler was inspected, it was found that two of the longitudinal braces were broken, and the head-sheet was bent out two inches.

#### MISCELLANEOUS ATTENTIONS.

If an engineer is going to take out an engine the first time after it has been in the shop for repairs, it is a good plan to examine the tank to see if the workmen have left it free from bagging, greasy waste, and other impediments, which are not conducive to the free action of pumps or injectors. Keeping the tank clean at all times saves no end of trouble through derangement to feeding-apparatus. The smoke-box door should be opened regularly, and the petticoat-pipe and cone examined. These things wear out by use, and it is better to have them renewed or repaired before they

break down on the road. A cone dropping down through failure of the braces makes a troublesome accident on the road. I have known of several cabs being badly damaged by fire through the cone dropping down and closing up the stack. Where engines have extended smoke-boxes, the nettings and deflectors must be inspected at frequent intervals.

#### REWARD OF THOROUGH INSPECTION.

To go over an engine in the manner indicated, requires perseverance and industry. The work will, however, bring its full reward to every man who practices the care and watchfulness entailed by regular and systematic inspection. It is the sure road to success. He who regards his work from a higher plane than that of mere labor well done, will experience satisfaction from the knowledge, that, understanding the nobility of his duties, he performed them with the vigor and intelligence worthy of his responsible calling.

## CHAPTER IV.

### GETTING READY FOR THE ROAD.

#### RAISING STEAM.

It used to be the universal custom, that, when an engine arrived from a trip, the fire was drawn, and the engine put into the round-house for ten or twelve hours before another run was undertaken. During this period of inaction, the boiler partly cooled down. When the engine was wanted again, a new fire was started in time to raise steam. The system of long runs, introduced on many roads, has changed this; and engines are now generally kept hot, unless they have to be cooled down for washing out, or repairs. When an engine comes in off a trip, the fire is cleaned from clinkers and dead cinders, and the clean fire banked. It is found that this plan keeps the temperature of the boiler more uniform than is possible with the cooling-down practice, and that the fire-box sheets are not so liable to crack, or the tubes to become leaky.

Where it is still the habit to draw the fire at the end of each trip, a supply of good wood is kept on hand for raising steam. On some roads the fires in the

locomotive fire-boxes are kindled by oil or greasy waste. To raise steam from a cold boiler, some theorists recommend the starting of a fire mild enough to raise the temperature about twenty degrees an hour. The exigencies of railroad service prevent this slow method from being practicable, and the ordinary practice is to raise steam as promptly as possible when it is wanted.

#### PRECAUTIONS AGAINST SCORCHING BOILERS.

The first consideration before starting a fire in a locomotive is to ascertain that the boiler contains the proper quantity of water. The men who attend to the starting of fires should be instructed not to depend upon the water-glass for the level of the water, but to see that it runs out of the gauge-cocks. I have known several cases where boilers were burned through those firing up being deceived by a false show of water in the glass, and starting the fire when the boiler was empty. If the boiler has been filled with water through the feed-pipes by the round-house hose, care should be taken to see that the check-valves are not stuck up. Where there is sand in the water, it frequently happens, that, in filling up with a hose, all the valves get sanded, and do not close properly. When there is steam on the boiler, this source of danger will generally be indicated at once by the steam and water blowing back into the tank; but, where the boiler is cold, the water flows back so silently and slowly, that the crown-sheet may be dry before the peril is discovered.

## STARTING THE FIRE.

The water being found or made right, the next consideration is the grates. Before throwing in the wood, all loose clinkers left upon the grates should be cleaned off: care should be taken, to see that the grates are in good condition, and connected with the shaker-levers. This is also the time to see that no accumulation of cinders is left on the brick arch, the water-table, or in the combustion-chamber, should the engine be provided with either of these appliances.

## FIREMAN'S FIRST DUTIES.

On most roads the engineer and fireman are required to be at their engine from fifteen minutes to half an hour before train-time. A good fireman will reach the engine in time to perform his preliminary duties deliberately and well. He will have the dust brushed off from the cab-furnishing and from the conspicuous parts of the engine, the deck swept clean, the coal watered, and the oil-cans ready for the engineer. His fire is attended to, and its make-up regulated,—the kind of coal used, the train to be pulled, and the character of the road on the start. With a level or down grade for a mile or two on the start the fire does not need to be so well made up as when the start is made on a heavy pull. But every intelligent fireman gets to understand in a few weeks just what kind of a fire is needed. It is the capability of perceiving this and other matters promptly that distinguishes a good from an indifferent fireman. When a young fireman pos-



sesses these "true workman" perceptions, and is of an industrious, aspiring disposition, anxious to become master of his calling, he will prove a reliable help to the engineer; and his careful attention to the work will insure comfort and success on every trip. There must be a certain amount of work done on the engine, to get a train along; and if the fireman cannot do his part efficiently it will fall upon the engineer, who must get it done somehow.

#### SAVING THE GRATES.

An important duty, which is never neglected by first-class firemen, before taking the engine away from the round-house, is that of looking to the grates, and seeing that the ash-pan is clean. When grates get burned, in nine cases out of ten it happens through neglecting the ash-pan. Some varieties of bituminous coal have an inveterate tendency to burn the grates. Such coal usually contains an excess of sulphur, which has a strong affinity for iron, and at certain temperatures unites with the surface of the grates, forming a sulphuret of iron. Neglecting the ash-pan, and letting hot ashes accumulate, prepares the way for bad coal to act on the grates. Keeping the ash-pan clear of hot ashes is the best thing that can be done to save grates, since that prevents the iron from becoming hot enough to combine with sulphur.

#### SUPPLIES.

Before starting out the fireman ought to ascertain that all the supplies necessary for the trip are in the

boxes; that the requisite flags, lanterns, and other signals are on hand, and that all the lamps are trimmed. He should also know to a certainty that all his fire-irons are on the tender, that the latter is full of water, and that the sand-box is full of sand.

These look like numerous duties as preliminary to starting, but they are all necessary; and the fireman who attends to them all with the greatest regularity will be valued accordingly. Nearly all firemen are ambitious to become engineers. The best method they can pursue, to show that they are deserving of promotion, is to perform their own duties regularly and well. A first-class fireman will save his wages each trip over the expenditure made by the mediocre fireman: a persistently bad fireman should be sent to another calling without delay. Few railroad companies can afford the extravagance of a set of bad firemen.

#### ENGINEER'S FIRST DUTIES.

Try the water. That is the most important call upon the engineer when he first enters the cab. If the engine has a glass water-gauge, he should ascertain by the gauge-cocks if the water-level shown in the glass be correct. A water-glass is a great convenience on the road, but it should only be relied on as an auxiliary to the gauge-cocks. Many engineers have come to grief through reposing too implicit confidence in the water-glass. Engineer Williams was considered one of the most reliable men on the A. & B. road. With an express train he started out on time one morning; and he had run only two miles when the boiler went up in

the air, with fatal results to both occupants of the cab. An examination of the wreck showed unmistakable evidence of overheated sheets. Circumstantial evidence indicated that the glass had deceived the engineer by a false water-level. When he pulled out, the fire-box sheets, which were of copper, became weakened by the heat, so that the crown-sheet gave way; the reaction of the released steam tearing the boiler to pieces. Numerous less serious accidents originating from the same cause might be cited.

#### REACHING HIS ENGINE IN GOOD SEASON.

An engineer who has a proper interest in his work, and thoroughly appreciates the importance of it, will reach his engine in time to perform the duties of getting her ready for the road leisurely, without rush or hurry. Although a good fireman may relieve the engineer of many preliminary duties, the engineer himself should be certain that the necessary supplies and tools are on the engine, and that water is in the tank, and the sand-box filled.

#### OILING THE MACHINERY.

Oiling the machinery is such an important part of an engineer's work, and the success of a fast run is so dependent upon this being properly done, that it should never be performed hurriedly. Although practice with short stoppages at stations may have got an engineer into the way of rushing round an engine and oiling at express speed, it is no reason why the first oiling of the trip should not be carefully and deliberately attended

to when there is an opportunity. In addition to filling oil-cups, lubricators, and oil-boxes, this is a good time to complete the inspection, which assures the engineer that everything about the engine is in proper running order. When anything in the way of repairs has been done to the engine since she came off the last trip, special attention has generally to be given to the parts worked at. New wheels require close care with the packing of the boxes; rod-brasses reduced entail an additional supply of oil to the pins for the first few miles; guides closed should insure a free supply of oil till it is found that the cross-heads run cool.

#### QUANTITY OF OIL THAT DIFFERENT BEARINGS NEED.

While oiling, the engineer should bear in mind that it is of paramount importance that the rubbing-surfaces receive lubrication sufficient to keep them from heating; but, while making sure that no bearings shall run dry, lavish pouring of oil should be avoided. There are still too many cases to be noticed, of men pouring oil on the machinery without seeming to comprehend the exact wants. We are constantly seeing cases where oil-cups waste their measure of oil through neglect in adjusting the feeders. A steady supply, equal to the requirements, is what a well-regulated cup provides. With the ordinary quality of mineral oil, six drops will lubricate the back end of a main rod for one mile when the engine is pulling a load. This applies to eight-wheel engines on passenger service. Heavier small-wheeled engines will require a quarter more oil. Guides can be kept moist with five drops

of oil to the mile. A dry, sandy road will require a more liberal supply. With good feeders, properly attended to, the supply can equal the demand with close accuracy. An oil-cup which runs out the oil faster than it is needed, wastes stores, besmears everything with a coating of grease, and is likely to leave the rubbing-surfaces to suffer by running dry before it can be replenished. A cup in that condition also advertises the engineer to be incompetent.

#### LEAVING THE ENGINE-HOUSE.

Before moving the engine out of the house, the cylinder-cocks should be opened so that water, or the steam condensed in warming the pipes and steam-chest, may escape. After ringing the bell, and giving workmen employed about the engine time to get out of the way, the throttle should be opened a little, and the engine moved out slowly and carefully. If there is a sufficient pressure of steam in the boiler, and the engine refuses to move, something is wrong. Never force an engine. Any work which may have been performed upon it while in the house will probably indicate the nature of the defect. The most common cause of stalling engines in the house is a miscalculation of the piston-travel, permitting it to push against the cylinder-head. Sometimes, however, the setting of the valves is at fault. I knew a case where the machinist connected the backing-up eccentric-strap with the top of the link, and the mistake was not discovered till they attempted to move the engine out of the house. Another blunder, the result of gross care-

lessness, was where a cold-chisel was left in the steam-chest. But a more representative case was that which happened to Engineer Amos, on the B. & C. road. His engine had the piston-packing set up; and the following morning, when he tried to take it out of the house, it would not pass a certain point. Thinking that the packing was set up rather tight, he backed for a start, determined to make it go over on the run. He succeeded, too, but a hammer which had been left in the cylinder went out through the cover.

While running from the round-house to the train, is a good time to carefully watch the working of the various parts of the engine. Should any defects exist, they are better to be detected now than after the engine is out with a train. The brakes can be tested conveniently at this time, and the working of the injectors tried. All these matters are regularly attended to by the successful engineer: they are habitually neglected by the unlucky man, and misfortune never loses sight of him.

## CHAPTER V.

### RUNNING A FAST FREIGHT TRAIN.

#### RUNNING FREIGHT TRAINS.

By far the greater proportion of American locomotive engineers are employed on freight service. On most roads, the freight engines constitute from seventy-five to ninety per cent of the whole locomotive equipment. On this kind of service, locomotive engineers learn their business by years of hard practice in getting trains over the road as nearly as possible on time. On the best of roads, there is much hardship to be undergone, working ahead through every discouragement of bad weather or hard-steaming engines. The man who brings the most energy, good sense, and perseverance to his aid, will come out most successfully above these difficulties.

Every department of locomotive engine running has difficulties peculiar to itself. Every kind of train needs to be handled understandingly, to show the best results; but, I think, getting a heavy fast freight train on time, over a hilly road, having a single track, requires the highest degree of locomotive engineering skill. Therefore, I have selected that form of train as the first subject of description.

#### THE ENGINE.

The engine that takes the train over the road is a ten-wheeler with cylinders  $18 \times 26$  inches, driving-wheels with 62-inch centers, and a total weight of 130,000 pounds. The steam-pressure carried on the boiler is 180 pounds per square inch, and the heating-surface and grate-area are sufficiently liberal to make steam freely at high or low speed. The tractive power of the engine at slow speed is about 20,000 pounds.

#### THE TRAIN.

This consists of 20 cars weighing about 700 tons.

#### THE DIVISION.

The physical character of the country, which is rolling prairie, makes the road undulatory,—up hill, then down grade, with occasional stretches of level track. Some of the gradients rise to fifty feet to the mile, extending over two miles without sagging a foot. Sound steel rails, well tied, are supported by a graveled road-bed, making an excellent track, and presenting a good opportunity for fast running where high speed is needed. The train is run on card-time, stopping about every twelve miles. Like most Western roads, the stations are unprotected by signals; and the safety of trains is secured mostly by vigilance on the part of the engineer and other train-men.



## PULLING OUT.

When the engineer gets the signal to go, he drops the reverse lever into the full forward notch, gives the engine steam gently, with due care to avoid breaking couplings, and applies sand. A slight sprinkling of sand only is dropped on the rails, which keeps the engine from slipping while getting the train under way. A clear, level fire is burning over the grates before the start is made, and this suffices till the most crowded switches are passed: so, when the signal to start is given, the fireman closes the fire-door, and opens the damper; these duties not preventing him from keeping a lookout for signals.

## HOOKING BACK THE LINKS.

As the engine gets the train into motion, the engineer gradually hooks up the links. This is not done by a sudden jerk as soon as the engine will move, with the steam cutting off short. He waits for that till the train is well under the control of the engine, hooking up gradually. Some men think that it is best to get the valves up to short travel as soon as possible, without reflecting that it is better for the motion to let the engine be going freely before hooking up short. I have often seen men coming into terminal stations with a heavy fire and the safety-valves blowing, and the engine toiling slowly along with the links hooked up to eight inches cut. In cases of this kind, a runner may better work the engine well down, so that the valve will travel freely over the seat. By doing so

when the engine is working slow and heavy, there will be less wear to the valves, and less danger of breaking a valve yoke. It is only in cases where there is an advantage in saving steam, that benefit is derived from working the engine close hooked back. There is a right time for all things, and working steam expansively is no exception to the rule. If, however, the start has been made with a light fire, the engineer ought to lose no time in getting the links well notched back to give the fireman an opportunity to make up his fire. While starting from stations it is all-important that engineer and fireman should co-operate together.

#### WORKING THE STEAM EXPANSIVELY.

At the right time, our engineer gets the reverse lever notched up; for he knows, that to obtain the greatest amount of work out of the engine, with the least possible expenditure of fuel, with a heavy freight train, the links must be hooked back as far as can be done consistently with making the required speed. Some engines will not steam freely when run close back if they are burning coal that needs a strong draught. This is the exception, however, and most engines will steam best in this position; and many of those that fail to steam well cutting off short are not properly fired, or the draught appliances need adjusting. Most firemen who run with a heavy fire fail worst with engines that steam indifferently when notched close up. Engineers should give this their attention, and do everything possible to make the en-

gine steam while working with the lever as near the center notch as can be done while handling the train.

#### ADVANTAGE OF CUTTING OFF SHORT.

When the links are notched close towards the center, the travel of the valves is so short that they close the steam-ports shortly after the beginning of the stroke, at six, nine, or twelve inches of the piston's travel, as the case may be, permitting the steam to push the piston along the remainder of the stroke by its expansive power. Steam at a high pressure is as full of potential energy as a compressed spiral spring, and is equally ready to stretch itself out when the closing of the port imprisons it inside the cylinder; and, by this act of expanding, it exerts immense useful energy, which would escape into the smoke-stack unutilized if the cylinders were left in communication with the boiler till the release took place. Suppose, for instance, that a boiler-pressure of 14 tons which this engine can develop is exerted upon the piston from the beginning to the middle of the stroke, and is then cut off. During the remainder of the stroke, the steam will continue to press upon the piston with a regularly diminishing force, till, at the end of the stroke, if release does not take place earlier, it will still have a pressure of seven tons. The work performed by the steam during the latter part of the stroke is pure gain, due to its expansive principle. If the steam is cut off earlier, at a third or fourth of the piston travel, the gain will be correspondingly great. With the slide-valve link-motion

used on locomotives, the steam cannot be held to the end of the stroke; but the principle of expansion holds good during the period the steam is held in the cylinders after the cut-off.

The observing engineer of any experience does not require to have the advantages of working his engine expansively impressed upon his attention. His fuel-record has done that more eloquently than pen can write.

#### DISADVANTAGE OF CUTTING OFF TOO SOON.

Working the steam expansively is, like nearly everything else in engineering, subject to modifications. With some steam-engines the steam cannot be expanded more than two or three times before the loss due to cylinder condensation becomes greater than the gain from expansion. No locomotives can be worked economically cutting off shorter than quarter stroke, and some engines do better if the steam is permitted to follow the piston a little farther before the cut-off takes place.

#### BOILER-PRESSURE BEST FOR ECONOMICAL WORKING.

There is a close and constant relation between the boiler-pressure carried, and the useful work obtained from expansion of steam. The higher the pressure, the greater elasticity the steam possesses. The tendency of modern steam-engineering is, to employ intensely high boiler-pressure, expanding the steam by means of a succession of cylinders, so that it is reduced to low tension before escaping into the atmos-

phere, or into the condenser, as the case may be. Wonderfully economical results have been obtained in this manner,—results which can never be approached in locomotive practice while the ordinary slide-valve is used. But, while we cannot hope to rival the record of high-class automatic cut-off engines, their methods can teach us useful lessons.

It is advisable to keep the steam constantly close to the blowing-off point. During a day's trip, considerably less water will be evaporated when a tension of 200 pounds is carried, than will be required with a pressure of 140 pounds or under. And, where less water is evaporated, a smaller quantity of fuel will be consumed in doing the work. Running with a low head of steam is a wasteful practice, for several good reasons. The comparatively light pressure upon the surface of the water allows the steam to pass over damp, or mixed with a light watery spray, which diminishes its energy; since the wet steam contains less expansive medium than dry steam. It requires nearly the same expenditure of fuel to evaporate water at the pressure of the atmosphere alone, that it does to make steam at the higher working tensions: consequently, the work obtained by the expansion of the high-pressed steam is clear gain over the results to be obtained by working at a low pressure. This is a very important principle in economical steam-engineering. Engineers who are accustomed to making long runs between water-tanks, when every gallon is needed to carry them through, know that their sure method of getting over the dry division successfully, is to carry

steam close to the popping-point, link up to the most economical point of cut-off, and see that no loss occurs through the safety-valves.

#### RUNNING WITH LOW STEAM.

There are engineers who habitually carry merely sufficient steam to get them along on time, under the mistaken belief that they are working economically. John Brown runs steadily, and takes as good care of his engine as any man on the A. & B. road; but he dislikes to hear the steam escaping from the safety-valves, and prevents it from doing so by habitually using steam thirty pounds below the blowing-pressure. The consequence is, that he always makes a bad record on the coal-list, compared with the other passenger men.

#### MANAGEMENT OF THE FIRE.

The engine has moved only a few rods from the station when the steam shows indications of blowing off; and then the fireman sets to work,—not to pile a heap of coal indiscriminately into the fire-box. That is the style of the dunce whose natural avocation is grubbing stumps. Ours is a model train, and a model fireman furnishes the power to keep it going. He throws in from one to three shovelfuls at each firing, scattering the coal along the sides of the fire-box shooting a shower close to the flue-sheet, and dropping the required quantity under the door. With the quick intuition of a man thoroughly master of his business, our model fireman perceives at a glance, on opening

the door, where the thinnest spots are; and they are promptly bedded over. The glowing, incandescent mass of fire, which shines with a blinding light that rivals the sun's rays, dazzles the eyes of the novice, who sees in the fire-box only a chaotic gleam; but the experienced fireman looks into the resplendent glare, and reads its needs or its perfections. The fire is maintained nearly level; but the coal is supplied so that the sides and corners are well filled, for there the liability to drawing air is most imminent. With this system closely followed, there is no difficulty experienced in keeping up a steady head of steam. But constant attention must be bestowed upon his work by the fireman. From the time he reaches the engine, until the hostler takes charge at the end of the journey, he attends to his work, and to that alone; and by this means he has earned the reputation of being one of the best firemen on the road. His rule is, to keep the fire up equal to the work the engine has to do, never letting it run low before being replenished, never throwing in more coal than the keeping up of steam calls for. The coal is broken up moderately fine, a full supply being prepared before the fire-door is opened; and every shovelful is scattered in a thin shower over the fire,—never pitched down on one spot. Some men never acquire the art of scattering the coal as it leaves the shovel; and, as a result, they never succeed in making an engine steam regularly. Their fire consists of a series of coal-heaps. Under these heaps, clinkers are prematurely formed; and between them spaces are created, through

which cold air comes, and rushes straight for the tubes, without assimilating with the gases of combustion, as every breath of air which enters the fire-box ought to do.

#### CONDITIONS THAT DEMAND GOOD FIRING.

Roads that are hilly require far more skillful management to get a train along than is called for on level roads, and the greater part of the extra dexterity is needed from the fireman. To get a heavy train up a steep hill, it is generally run at a high speed before reaching the grade, so that the momentum of the train can be utilized in climbing the ascent. Running for a hill is a particularly trying time on the fireman; for the engine is rushing at a high speed, and often working heavily. This ordeal must be prepared for in advance, by having the fire well made up, and kept at its heaviest by frequent firing. When the engine gets right on to the grade, toiling up with decreasing speed, every pound of steam is needed to save doubling, and steady watchfulness is required to prevent a relapse of steam; but the danger of the engine "turning" the fire is not nearly so great as it was when running fast for the hill.

#### HIGHEST TYPE OF FIREMAN.

The highest type of fireman is one who, with the smallest quantity of fuel, can keep up a good head of steam without wasting any by the safety-valves. He endeavors to strike this mean of success by keeping an even fire; but it sometimes happens, that the closest



care will not prevent the steam from showing indications of blowing off. When this is the case, he keeps it back by closing the dampers, or, if that is not sufficient, opens the door a few inches. Immense harm is done to tubes and fire-boxes by injudicious firing.

When the train is ready to start, there is a glowing fire on the grates, sufficient to keep up steam until the reverse-lever is notched back after the train has worked into speed. With heavy freight trains this firing is made sufficient, so that the door has not to be opened until the tremendous exertion of starting is over. When the time for replenishing the fire arrives, the good fireman knows either from instruction or by observation that the effect of throwing fresh coal into the burning mass of the fire-box is similar to that of pouring a dipperful of cold water into a boiling kettle. The cold coal cools the fire, and if thrown in in large quantities its tendency is to depress the burning mass for a brief time below the igniting-point. A small quantity of cold water does not check the boiling of a kettle much, and three or four shovelfuls of coal are little felt on the fire of a big locomotive; so our man throws in only a few scoopfuls at a time, is quite deliberate in applying each charge, scattering it over the surface of the burning mass, so that each portion of fresh supply quickly gives up its hydrocarbon gases and becomes a vital addition to the bed of incandescent fuel. This bed of glowing fuel, on which the fresh coal is thrown, being comparatively thin, a supply of air passes through sufficient to provide the necessary oxygen to the hydrocarbons released, and the gases

are burnt with the high generation of heat of which they are capable.

#### SHAKING THE GRATES.

Should indications appear that the fire is not receiving sufficient air, our fireman gently shakes the grates, an operation which is repeated during the trip at intervals sufficient to keep the fire as clean as possible. No act marks the poor fireman so strongly as his method of shaking grates. He does the work so violently and so frequently that a great deal of fuel is wasted. The fire is perniciously disturbed, and unless it is very heavy, holes are made which admit the cold air. Good coal requires no more grate-shaking than what will prevent clinkers from hardening between the grate-openings. Coal that contains a great deal of ash will be burned to greater advantage when the grates are shaken lightly and frequently, and this shaking should be done by short, quick jerks. The long, slow movement that some men give the grates, in shaking, merely moves the clinkers resting upon them. The purpose of shaker-grates is to provide a means of breaking the clinker, so that it will fall into the ash-pan and permit the dead ashes to fall.

#### AT STOPPING-POINTS.

When approaching a stopping-place, our fireman takes care to have sufficient fuel in the fire-box, so that he will not have to begin firing until the start is made. When this has not been done, a fresh supply of coal should be applied while the engine is standing at the

station. The common practice of throwing open the door and beginning to fire as soon as the throttle is open, is very hard on fire-boxes, because the cold air drawn through the door strikes the fire-box sheets and tubes, contracting the metal and tending to produce leakage. Firing just as a train is pulling out of a station is bad for another reason—at that time the fireman ought to be looking out for signals.

#### FIRES TO SUIT THE WORK TO BE DONE.

The good fireman maintains the fire in a condition to suit the work the engine has to do. At parts of the road where there are grades that materially increase the work to be done, he makes the fire heavier to suit the circumstances, but this is done gradually, and not by pitching a heavy charge of fresh coal into the fire-box at one time. This system of firing keeps the temperature of the boiler as even as possible, and has the double result of being easy on the boiler and using coal to the best advantage. From the time he reaches the engine until the hostler takes charge at the end of the journey, this fireman attends to his work, and to his work alone. It is only by concentrated attention to the work to be done that a fireman can do it in a first-class manner.

There are circumstances where the method of firing described would not be a success, because certain coals and certain engines require special treatment. But, in a general way, the methods described are those of the most successful firemen.

SCIENTIFIC METHODS OF GOOD FIREMEN.

It is not necessary that a man should be deeply read in natural philosophy to understand intimately what are actually the scientific laws of the business of firing. Mr. Lothian Bell, the eminent metallurgist, somewhere expresses high admiration for the exact scientific methods attained in their work by illiterate puddlers. Although they knew nothing about chemical combinations or processes they manipulated the molten mass so that, with the least possible labor, the iron was separated from its impurities. In a similar way, firemen skillful in their calling have, by a process of induction, learned the fundamental principles of heat-development. By experiments, carefully made, they perceive how the greatest head of steam can be kept up with the smallest cargo of coal; and they push their perceptions into daily practice.

If an accomplished scientist were to ride on the engine, observing the operations of a first-class fireman, he would find that nearly all the carbon of the coal combined with its natural quantity of oxygen to produce carbon dioxide, thereby giving forth its greatest heat-power; and that the hydrocarbons, the volatile gases of the coal, performed their share of calorific duty by burning with an intensely hot flame. He would find that these hydrocarbon gases, although productive of high-power duty when properly consumed, were ticklish to manage just right, for they would pass through the tubes without producing flame if they were not fully supplied with air; and, if the supply of air were too liberal, it would reduce the

temperature of the fire-box below the igniting-point for these gases, which is higher than red-hot iron, and they would then escape in the form of worthless smoke. Our model fireman manages to consume these gases as thoroughly as they can be consumed in a locomotive fire-box.

#### THE MEDIUM FIREMAN.

John Barton is considered a first-class fireman by some men. He works hard to keep up steam, and is never satisfied unless the safety-valves are screaming. He carries a heavy fire all the time; and, when the pop-valves rise, he pulls the door open till they subside, gets in a few shovelfuls more coal, closes the door till the steam blows off again, and repeats the operation of throwing open the door. This man has learned only the half of his business. He has got through his head how to keep up steam, but he has not acquired the more delicate operation of keeping it down wisely and well. Training with an intelligent engineer anxious to make a good fuel-record, will, in a few months, improve Barton wonderfully. Barton is the medium fireman.

#### THE HOPELESSLY BAD FIREMAN.

Behind him comes Tom Jackson, the man of indiscriminately heavy firing. Tom's sole aim is to get over the road with the least possible expenditure of personal exertion. He tumbles in a fire as if he were loading a wagon, the size of the door being his sole gauge for the lumps. When the fire-box is filled to the neighborhood of the door, he climbs up on the

seat, and reclines there till the steam begins to go back through drawing air; then he gets down again, and repeats the filling-up process, intent only on getting upon the seat-box with as little delay as possible.

Some men are so constituted that they never make good firemen, no matter how much they may try. The average bad fireman is, however, of that quality because he never tries to be a good one. The average bad fireman is careless about how his work is done; indifferent about how his inferiority may cause delay to trains, annoyance to the engineer, or expense to the company. All he cares for is to get through his work with as little personal exertion as possible. It often happens that his efforts to shirk the most necessary part of his work greatly increase his labors before a trip is finished; yet he will go through the same performance on the next run.

When called to go out on a run, the poor fireman reaches the engine-house just as it is time to start for the train. He pitches some coal into the fire-box, and sweeps the cab and waters the coal as the engine is on its way to the starting-point. As soon as the engine pulls out, working hard to force the train into speed, this fireman pulls open the fire-door and throws in a heavy load of coal. Steam begins to go back and the engineer shuts off the injector. As the fire burns through, the steam comes up; and just as the engineer finds it necessary to start the injector again, the fireman jerks open the fire-door and pitches in eight or ten shovelfuls of coal as fast as he can drop it inside the door; then he climbs up on the seat and waits for

the black smoke ceasing to flow from the stack as the signal to get down and repeat his method of firing.

Finding that the engine is not steaming freely under his treatment, he gets down reluctantly and tears up the fire by violent use of the shaking-lever. When the train reaches a stopping-place, this kind of fireman occupies himself looking at the sights, and pays no attention to the fire until the signal to start is given, when he throws open the door again and repeats the operation of firing followed at the first start.

By this method of firing small mounds of coal are dropped promiscuously over the grates. In intervening spots the grates are nearly bare, and cold air passes through without meeting carbon to feed upon, and not sufficiently heated to ignite with the volatile compounds distilling from the mounds. The product is worthless smoke. Each mound is a protection for the formation of clinker, which grows so rapidly that the shaking-bar has to be frequently toiled on to let sufficient air through the fire to make steam enough for making slow time.

The result of this fireman's way of working is irritation all round. Towards the end of the trip he is overworked, throwing the extra coal needed and the hard shaking of grates. At every stopping-place he has to crawl beneath the engine to clean the ash-pan, and is fortunate if the grates are not partly burned. The practical result for this man's employers is that he has burned from 25 to 35 per cent more coal than a first-class fireman would need for doing the same work.

## CHAPTER VI.

### GETTING UP THE HILL.

#### SPECIAL SKILL AND ATTENTION REQUIRED TO GET A TRAIN UP A STEEP GRADE.

IN the last chapter, some details were given of the methods pursued in starting out with a heavy fast freight train. Where a train of that kind has to climb heavy grades, special skill and attention are needed in making the ascent successfully.

#### GETTING READY FOR THE GRADE.

The track for the first two miles from the starting-point is nearly level, permitting the engineer and fireman to get ready for a long pull not far distant. At the second mile-post a light descending grade is reached, which lasts one mile, and is succeeded by an ascending grade two and a half miles long, rising fifty-five feet to the mile.

#### WORKING UP THE HILL.

At the top of the descending grade, the engineer hooks up the links, using a light throttle while the train is increasing in speed, until the base of the



ascent is nearly reached, when he gets the throttle full open, letting the engine do its best work in the first notch off the center. By this time the train is swinging along thirty miles an hour, and is well on to the hill before the engine begins to feel its load. Decrease of speed is just becoming perceptible when the valve-travel gets the benefit of another notch, and the engine pulls at its load with renewed vigor. But soon the steepness of the ascent asserts itself in the laboring exhausts; and the reverse-lever is advanced another notch, to prevent the speed from getting below the velocity at which the engine is capable of holding the train on this grade. While the engineer is careful to maintain the speed within the power of his locomotive, he is also watchful not to increase the valve-travel faster than his fire can stand it; for, were he to jerk the lever two or three notches ahead at the beginning of the pull, the chances would be that he would "turn" its fire, or tear it up so badly that the steam would go back on him before he got half a mile farther on. Before the train is safe over the summit, it will probably be necessary to have the engine working down to 21 inches: but the advance to this long valve-travel is made by degrees; each increase being dependent upon, and regulated by, the speed. The quadrant is notched to give the cut-off at 6, 9, 12, 15, 18, 21, and 23 inches. Repeated experiments, carefully watched, have convinced the engineer of this locomotive that its maximum power is exerted in the 21-inch notch; so he never puts the lever down in the "corner" on a hill. A great many engines act differently, however, showing increased

power for every notch advanced. If the cars in the train should prove easy running,—and there are great differences in cars in this respect,—it may not be necessary to hook the engine below 15 inches, or even 12 will suffice for some trains; but this can only be determined by seeing how the engine holds the speed in the various notches.

#### WHEEL-SLIPPING.

As the engine gets well on to the grade, and is exerting heavy tractive power, the wheels are liable to commence slipping; and it is very important that they should be prevented from doing so. An ounce of prevention is known to be worth a pound of cure; and it pays an engineer to assure himself that no drips from feed-pipes, or cylinder-cocks, or from any other fountain, are dropping upon the rails ahead of the driving-wheels. There is no use telling an engineer of the decreased adhesion which the drivers exert on half-wet rails, from what they do on those that are clean and dry. Knowing the difference in this respect, every engineer should endeavor to prevent the wetting of the rails by leaks from his engine; for hundreds of engines get “laid down” on hills from slipping induced by this very cause.

#### HOW TO USE SAND.

The first consideration in this regard is to have clean, dry sand, and easy-working box valves. Then the engineer should know how far the valves open by the distance he draws the lever. In starting from a station,

or working at a point where slipping is likely to commence, the valves should be opened a little, and a slight sprinkling of sand dropped on the rails. This often serves the purpose of preventing slipping just as well as a heavy coating of sand. And it has none of the objectionable features of thick sanding. Trains often get stalled on grades by the sand-valves being allowed to run too freely. It is not an uncommon occurrence for engineers to open the valves wide, and let all the sand run upon the rails that the pipe will carry, so that a solid crust covers each rail, and every wheel on the train gets clogged with the powdered silica; and, after the train has passed over, a coating is left for the next one that comes along.

The wheels scatter their burden of powdered sand into the axle-boxes, and it grinds its way inside the rod-brasses, and part of it gets wafted upon the guides; and in all these positions it is matter decidedly in the wrong place. And this body of sand under the wheels increases the resistance in the same way as a wagon is harder to pull among gravel than it is on a clean, hard road: the indiscreet engineer complains about the train being stiff to haul; and the chances are, that he goes twice up the hill before the whole train is got over. Uncle Toby's plan is, when pulling on a heavy grade, to open the valve enough to let the drivers leave a slight white impression on the rails. If they slip, he gives a few particles more sand, but decreases the supply again so soon as the drivers will hold with the diminished quantity. Uncle Toby seldom needs to double a hill.

These remarks are for the use of men running engines with the common sand-boxes and valves. The modern locomotives have automatic devices which place the sand where it will do the most good and does not cause waste and annoyance by dropping an over-supply.

All efficient engineers are careful not to have their sanding-apparatus in the condition that only one sand-pipe is feeding. That is a common cause of broken crank-pins and side-rods.

#### SLIPPERY ENGINES.

These remarks apply to ordinary engines with ordinary rail-conditions. Occasionally we find an engine inveterately given to slipping, and no conditions seem able to keep it down. Such an engine is as ready to whirl its wheels as an ugly mule is to kick up its heels, and upon as little provocation. With a dirty, half-wet rail, an engine of this kind loses half its power. The causes that make an engine bad for slipping are various. Excess of cylinder-power or very hard steel tires, are the most frequent causes of slipping; but badly worn tires sometimes produce a similar effect; or the blame may rest in a short wheel-base, deficiency in weight, or in too flexible driving-springs. To get a slippery engine over the road when the rails are moist and dirty, requires the exercise of unmeasured patience by the engineer. The tendency of an engine to slip may be checked to some extent by working with the lever well ahead towards full stroke, and throttling the steam. This gives a more uniform piston-pres-

sure than is possible while working expansively. Of two evils, it is best to choose the least. The smallest in this case is losing the benefits of expansion, and getting over the road.

#### FEEDING THE BOILER.

Some engineers claim that the most economical results can be obtained from an engine by running with the water as low as possible, consistent with safety. They hold, that, so long as the water is sufficiently high to cover the heating-surfaces, there is enough to make steam from; and the ample steam-room remaining above the water assures a more perfect supply of dry steam for the cylinders than can be had from the more contracted space left above a high water-line. Old engineers, running locomotives furnished with entirely reliable feeding-apparatus, may be able to carry a low water-level advantageously, especially with light trains and level roads; but with ordinary men, average injectors, and the common run of roads a high water-level is safest. With a high water-level the temperature of the boiler can be kept nearly uniform; for the increased volume of water holds an accumulated store of heat, which is not readily affected by the feed. And the surplus store is convenient to draw upon in making the best of a time-order, or in getting over a heavy grade. Then, if the injectors fail, a full boiler of water often enables a man to examine the delinquent feeding-apparatus, and set it going; whereas, with low water, the only resource would be to dump the fire.



The right-hand injector is used most for feeding the boiler, but several times during each trip the left-hand injector is called into service, a thing necessary to keep it in good working order. On a heavy grade one injector will not supply all the water necessary for steam-making, and the other is put to work. This is generally done when the slow, heavy pull begins and the steam reaches near to the blowing-off point. During the remainder of the ascent, the water is supplied as liberally as it can be carried; and the top of the grade finds the engine with a full boiler. This enables the engineer to preserve a tolerably even boiler temperature; for in running down the long descent which follows, where the engine runs several miles without working steam, the injectors can be shut off, and sudden cooling of the boiler avoided. The preservation of flues and fire-box sheets depends very much upon the manner of feeding the water. Some men are intensely careless in this matter. In climbing a grade, they let the water run down till there is scarcely enough left to cover the crown-sheet when they reach the summit. Then they dash on the feed, and plunge cold water into the hot boiler, which is then peculiarly liable to be easily cooled down, owing to the limited quantity of hot water it contains. The fact of having the steam shut off, greatly aggravates the evil; for there is then no intensity of heat passing through the flues to counteract the chilling effect of the feed-water. If it is necessary to feed while running with the steam shut off, the blower should be kept going; which will, in some measure, prevent the

change of temperature from being dangerously sudden. There will probably be some loss from steam blowing off, but this is the smaller of two evils.

Engineers are not likely to feed the boiler too lavishly when working hard, for the injection of cold water instantly shows its effect by reducing the steam-pressure. But this is not the case when running with the throttle closed. The circulation in the boiler is then so sluggish, that the temperature of the water may be reduced many degrees, while the steam continues to show its highest pressure.

Writers on physical science tell us that the temperature of water and steam in a boiler is always the same, and varies according to pressure; that, at the atmosphere's pressure, water boils at 212 degrees, and produces steam of the same temperature. At 10 pounds above the atmospheric pressure, the water will not evaporate into steam until it has reached a temperature of 240 degrees, and so on: as the pressure increases, the temperature of water and steam rises. But under all circumstances, while the water and steam remain in the same vessel, their temperature is the same. This is an acknowledged law of physical science; yet every locomotive engineer of reflection, who has run on a hilly road, knows that circumstances daily happen where the law does not hold good.

#### CAREFUL FEEDING AND FIRING PRESERVE BOILERS.

A case where the conservative effect of careful firing and feeding was strikingly illustrated once came under the author's notice. During the busiest part of the

season, the fire-box of a freight engine belonging to a Western road became so leaky that the engine was really unfit for service. Engines, like individuals, soon lose their reputation if they fail to perform their required duties for any length of time. This engine, "29," soon became the aversion of trainmen. The loquacious brakeman, who can instruct every railroadman how to conduct his business, but is lame respecting his own work, got presently to making big stories out of the amazing quantity of water and coal that "29" could get away with, and how many trains she would hold in the course of a trip. The road was suffering from a plethora of freight and extreme scarcity of engines; and on this account the management was reluctant to take this weakling into the shop. So the master mechanic turned "29" over to Engineer Macleay, who was running on a branch where delays were not likely to hold many trains. Mac deliberated about taking his "time" in preference to the engine, which others had rejected, but finally concluded to give the bad one a fair trial. The first trip convinced the somewhat observant engineer that the tender fire-box was peculiarly susceptible to the free use of the pump, and to sudden changes of the fire's intensity of heat. So he directed the fireman to fire as evenly as possible, never to permit the grates to get bare enough to let cold air pass through, to keep the door closed except when firing, to avoid violent shaking of the grates, and never to throw more than two or three shovelfuls of coal into the fire-box at one time. His own method was, to feed with persistent regularity, to



go twice over heavy parts of the division in preference to distressing the engine by letting the water get low, and then filling up rapidly. This system soon began to tell on the improved condition of the fire-box. The result was that within a month after taking the engine, Mac was pulling full trains on time; and this he continued to do for five months, till it was found convenient to take the engine in for rebuilding.

#### OPERATING THE DAMPERS.

According to the mechanical dictionary, a damper is a device for regulating the admission of air to a furnace, with which the fire can be stimulated, or the draught cut off, when necessary. Some runners regard locomotive dampers in a very different light. They seem to think the openings to the ash-pan are merely holes made to let air in, and ashes out; that doors are placed upon them, which troublesome rules require to be closed at certain points of the road to prevent causing fires. Those who have made their business a study, however, understand that locomotive dampers are as useful, when properly managed, as are the dampers of the base-burner which cheers their homes in winter weather. To effect perfect combustion in the fire-box, a certain quantity of oxygen, one of the constituents of common air, is required to mix with the carbon and carbureted hydrogen of the coal. The combination takes place in certain fixed quantities. If the quantity of air admitted be deficient, a gas of inferior calorific power will be generated. On the other hand, when the air-supply is in excess of that

needed for combustion, the surplus affects the steam-producing capabilities of the fire injuriously; since it increases the speed of the gases, lessening the time they are in contact with the water-surface, and a violent rush of air reduces the temperature of portions of the fire-box below the heat at which carbureted hydrogen burns.

#### LOSS OF HEAT THROUGH EXCESS OF AIR.

In the fire-boxes of American engines, where double dampers are the rule, far more loss of heat is occasioned by excess of air than there is waste of fuel through the gases not receiving their natural supply of oxygen. The blast from the nozzles creates an impetuous draught through the grates; and when to this is added the rapid currents of air impelled into the open ash-pan by the violent motion of the train, the fire-box is found to be the center of a furious wind-storm. The excess of this storm can be regulated by keeping the front damper closed, and letting the engine draw its supply of air through the back damper. When the fire begins to get dirty, and the air-passages between the grates become partly choked, the forward damper can be opened with advantage. So long as an engine steams freely with the front damper closed, it is an indication that there is no necessity for keeping it open. With vicious, heavy firing, all the air that can be injected into the fire-box is needed to effect indifferently complete combustion; and the man who follows this wasteful practice cannot get too much air through the fire. Consequently, it is only with

moderately light firing that regulation of draught can be practiced. Running with the front damper open all the time is hard on the bottom part of the fire-box, and the ever-varying attrition of cold wind is responsible for many a leaky mud-ring.

#### LOSS OF HEAT FROM BAD DAMPERS.

In Europe, where far more attention has been devoted to economy of fuel than has been bestowed upon the matter this side of the Atlantic, locomotives are provided with ash-pans that are practically airtight, and the damper-doors are made to close the openings. In many instances, the levers that operate the dampers have notched sectors, so that the quantity of air admitted may equal the necessities of the fire. European locomotives, as a rule, show a better record in the use of their fuel than is found in American practice; and a high percentage of the saving is due to the superior damper arrangements.

Imagine the trouble and expense there would be with a kitchen stove that had no appliance for closing the draught! Yet some of our locomotive-builders turn out their engines with practically no means of regulating the flow of air beneath the fire.

## CHAPTER VII.

### FINISHING THE TRIP.

#### RUNNING OVER ORDINARY TRACK.

THE hill which our train encounters nearly at the beginning of the journey is the hardest part of the division. The style in which it is ascended shows what kind of an engine pulls the train, and it tests in a searching manner the ability of the engineer. Our engine has got over the summit successfully; and the succeeding descent is accomplished with comfort to the engine, and security to the train. And so the rest of the trip goes on. The train speeds merrily along through green, rolling prairies, away past leafy woodlands and flowery meadows: it cuts a wide swath through long cornfields, startles into wakefulness the denizens of sleek farmhouses, and raises a rill of excitement as it bounds through quiet villages. But every change of scene, every varied state of road-bed,—level track, ascending or descending grade,—is prepared for in advance by our enginemen. Their engine is found in proper time for each occasion, as it requires the exertion of great power, or permits the conservation of the machine's energy. Over long stretches of un-

dulatory track the train speeds; each man attending to his work so closely that the index of the steam-gauge is almost stationary, and the water does not vary an inch in the glass. This is accomplished by regular firing and uniform boiler-feeding, two operations which must go together to produce creditable results.

#### STOPPING-PLACES.

There are few stops to be made, and these are mostly at water-stations. Here the fireman is ready to take in water with the least possible delay; and, while he is doing so, the engineer hurries around the engine, feeling every box and bearing, and dropping a fresh supply of oil where necessary. And, while going thus around, he glances searchingly over the engine, his eye seeking to detect absent nuts, or missing bolts or pins: anything wrong may now be observed and remedied.

At the coaling-stations the fireman finds time to rake out the ash-pan, and the engineer bestows upon the engine and tender a leisurely inspection besides oiling around.

#### KNOWLEDGE OF TRAIN-RIGHTS.

Next to studying the idiosyncrasies of his engine, our model engineer prides himself on his intimate acquaintance with the details of the time-table. The practice becoming so common on our best-regulated railroads, of examining candidates for promotion to the position of engineer on their knowledge of the time-

table, has a very salutary effect upon aspiring firemen, and induces them to acquire familiarity with the rules governing train-service, which they never forget.

Our engineer is well posted on all the rules relating to the movement of trains; his mind's eye can glance over the division, and note meeting or passing points; and the relative rights of each train stand blazoned forth in bold relief before his mental vision. This knowledge regulates his conduct while nearing stations; for, although every stopping-point is approached cautiously, those places where trains may be expected to be found are run into with vigilant carefulness, the train being under perfect control. Depending blindly upon conductors and brakemen to keep safe control of the train at dangerous points is opening the gate of trouble. An engineer is jointly responsible with the conductor for the safety of his train, and he should make certain that every precaution is taken to get over the road without accident.

On some roads the rules require the engineer to show his train-orders to the fireman. No rule ought to be necessary to insure this practice being regularly followed. Two heads are better than one when memory of where trains are to be met is concerned. Not a few engineers have escaped forgetting train-orders by showing them to the fireman.

#### PRECAUTIONS TO BE OBSERVED IN APPROACHING AND PASSING STATIONS.

Running past stations where trains are standing side-tracked, requires to be done with special care, particu-

larly in the case of passenger trains; for, at such points, there is danger of persons getting injured by stepping inadvertently past a car or a building, in front of a moving train. This peril is guarded against by reducing the speed as far as practicable, after whistling to warn all concerned, by ringing the engine-bell and keeping a sharp lookout from the cab.

THE BEST RULES MUST BE SUPPLEMENTED BY  
GOOD JUDGMENT.

Rules framed by the officers of our railways for the guidance of employés are always safe to follow as far as they go, and neglect of their behests will soon entail disaster. But circumstances sometimes arise in train-service to which no rule applies, and the men in charge must follow the dictates of their judgment. This happens often, especially on new roads; and the men who prove themselves capable of wrestling successfully with unusual occurrences, of overcoming difficulties suddenly encountered, are nature's own railroaders. It is this practice of acting judiciously and promptly, without the aid of codified directions, which gives to American railroadmen their striking individuality, known to the men of no other nation following the same calling. European railway servants carry ponderous books of "rules and regulations" in their pockets, and these rules are expected to furnish guidance for every contingency; so, when an engine-driver or guard gets into an unusual dilemma, he turns over the pages of his rule-book for counsel and direction. The American engineer or conductor under

similar circumstances takes the safe side, and goes ahead.

#### OPERATING SINGLE TRACKS SAFELY.

For many years to come the great majority of our railroads will be single tracks, as they now are. The operating of single-track roads is only done safely by the exercise of unsleeping vigilance on the part of all concerned in the movement of trains. Delays sometimes occur through mistaken excess of caution, as in the case of an engineer in Iowa, who mistook the lantern of a benighted farmer for the headlight of an approaching train, and backed to the nearest telegraph-station; or that of a conductor in Michigan, who side-tracked his train to let the evening star pass. Such mistakes make pleasantry among trainmen, but all acknowledge that it is better to err on the safe side than to run recklessly into danger.

#### CAUSES OF ANXIETY TO ENGINEERS.

The anxiety upon the part of the engineer is not occasioned by fear for his personal safety, though that doubtless has its influence; but it is the knowledge, born of observation and experience, that blind adherence to orders, no matter what the circumstances, or from whom emanating, may not only cost him his life, but may involve the lives of many others,—the lives of people believing in him, and trusting in him, and as unconscious of danger as they are helpless to avoid it.



## ACQUAINTANCE WITH THE ROAD.

Next in importance to knowing well how to manage the engine, and intimate familiarity with the time-table and its rules, comes acquaintance with the road. In the light of noonday, when all nature seems at peace, when every object can be seen distinctly, the work of running over a division is as easy as child's play. But when thick darkness covers the earth, when the fitful gleam of the headlight shines on a mass of rain, so dense that it seems like a water wall rising from the pilot, or when blinding clouds of snow obliterate every bush and bank, it is important that the engineer should know every object of the wayside. A person unaccustomed to the business, who rides on a locomotive tearing through the darkness on a stormy night, sees nothing around but a black chaos made fitfully awful by the glare from the fire-box door. But even in the wildest tempest, when elemental strife drowns the noise of the engine, the experienced engineer attends to his duties calmly and collectedly. A cutting or embankment, a culvert or crossing, a tree or bush, is sufficient to mark the location; and every mile gives landmarks trifling to the uninitiated, but to the trained eye significant as a lighted signal. One indicates the place to shut off steam for a station, another tells that the train is approaching a stiff-pull grade; and the enginemen act on the knowledge imparted. And so the round of the work goes. Working and watching keep the train speeding on its journey. Nothing is left to chance or luck: every movement, every varia-

tion of speed, is the effect of an unseen control. As a stately ship glides on its voyage obedient as a thing of life to the turn of the steersman's wheel; so the king of inland transportation, the locomotive engine, the monarch of speed, the ideal of power in motion, pursues its way, annihilating space, binding nations into a harmonious unit, and all the time submissive to the lightest touch of the engineer's hand.

To get a freight train promptly over the road day after day, or night after night, an engineer must know the road intimately, not only marking the places where steam must be shut off for stations or grades, but every sag and rise must be engraved on his memory. Then he will be prepared to take advantage of slight descents to assist in getting him over short pulls, where, otherwise, he would lose speed; and the same knowledge will avail him to avoid breaking the train in two while passing over the short depressions in the track's alignment, called sags in the West.

#### FINAL DUTIES OF THE TRIP.

With an engine properly fired, there is but little special preparation needed for closing up the trip without waste of fuel. The fire is regulated so that a head of steam will be retained sufficient to take the engine into the round-house after the fire-box is cleaned out. In drawing the fire, the blower should be used as sparingly as possible; for its blast rushes a volume of cold air through the flues, which is apt to start leaks. Many engineers find flues, or stay-bolts, which were dry at the end of one trip, leaking when the engine is taken

out for the next run. In nine cases out of ten, the cause has been too much blower. So soon as the ash-pan is cleaned out the dampers should be closed so that the fire-box and flues may cool down gradually.

#### PULLING PASSENGER TRAINS.

The enginemen who acquire the art of taking a fast freight train over the road on time will experience no difficulty in handling passenger trains after a little experience. All the rules that apply to handling freight trains are suitable for passenger trains with very little modification.

## CHAPTER VIII.

### HARD-STEAMING ENGINES.

#### IMPORTANCE OF LOCOMOTIVES STEAMING FREELY.

As the purpose of a locomotive engine attached to a train is to take that train along on time, and as engines are generally rated to pull cars according to their size, it is of the utmost importance that they should make steam freely enough to keep up an even pressure on the boiler while the cylinders are drawing the supply necessary to maintain speed. A locomotive that does not generate steam as fast as the cylinders use it is like a lame horse on the road, a torture to itself and to every one connected with it.

#### ESSENTIALS FOR GOOD-STEAMING ENGINES.

To steam freely, an engine must be built according to sound mechanical principles. The locomotives constructed by our best manufacturers, the engines which keep the trains on our first-class roads moving like clock-work, are designed according to proportions which experience has demonstrated to be productive of the most satisfactory results for power and speed, combined with economy. There are certain charac-

teristics common to all good makers. The valve-motion is planned to apply steam to the pistons at nearly boiler-pressure, with the means of cutting off early in the stroke, and retaining the steam long enough in the cylinders to obtain tangible benefits from its expansive principle. Liberal heating-surface is provided in the boiler, its extent being regulated by the size of the cylinders to be supplied with steam. With a good valve-motion, and plenty of heating-surface served with the products of good coal, an engine must steam freely if it is not prevented from doing so by malconstruction or adjustment of minor parts, or by the wasting of heat in the boiler or in the cylinders.

An engine of that kind will steam if it is managed with any degree of skill. But as the best lathe ever constructed will turn out poor work under the hands of a blundering machinist, so the best of locomotives will make a bad record when run without care or skill. Regular feeding—the water supplied at a rate to equal the quantity evaporated, which will maintain a nearly level gauge—is an essential point in successful running. It is hardly second in importance to skillful firing.

#### CAUSES DETRIMENTAL TO MAKING STEAM.

When an engine is steaming badly, almost the first action of an experienced engineer is to examine the draught appliances in the smoke-box. These appliances are designed to regulate the pull of the draught upon the fire so that the gases of combustion will pass evenly through all the tubes, and to prevent the

throwing of sparks. The two duties do not always harmonize, and the deflector-plate in front of the tubes is frequently set more with a view to the prevention of spark-throwing than to the regulating of the draught. When this is done, the engine will not steam freely. A medium point should be found in which the draught will receive no more interruption than what is necessary to make the flow of the gases uniform through the tubes. If the engine is fired properly under this condition, there is not likely to be much cause for complaint from spark-throwing.

#### PETTICOAT-PIPE.

The petticoat-pipe performs, in relation to draught, functions of a similar nature to those performed by the tubes of an injector in inducing the flow of water; and its efficiency is reduced by the same disturbing agencies. This pipe must have a size in proportion to the diameter of the stack, and it must be set so that it shall deliver the exhaust-steam to make a straight shoot through the stack. When these conditions are properly arranged, the exhaust-steam goes through the stack like a piston, leaving a vacuum behind. The petticoat-pipe is a device confined mainly to American locomotives; and its purpose is the same as the deflector in engines having open stacks: to regulate the draught in the smoke-box so that the currents of hot gases are drawn uniformly through the flues, the top, bottom, and sides getting about the same heating intensity as passes through the middle rows. The opportunity

for the exhibition of good firing depends greatly upon the petticoat-pipe being constructed properly, and secured at the right position. It is impracticable to lay down a positive rule for dimensions and best position of these pipes, for engines of the same proportions frequently require different petticoat-pipe arrangements to make them steam freely. When engines with sufficient heating-surface do not steam freely, the trouble nearly always lies in malproportioned or badly set petticoat-pipes, or badly set deflectors. Sometimes a very small change in the position of this deflector or pipe will have a wonderful effect upon the steaming qualities of the engine. If the pipe is set too high, most of the draught will pass through the lower flues; and the upper rows will become filled with soot, and many of them are likely to get choked with fine ashes, which remains there for want of draught to force it out. Should it be too low, the bottom rows of flues will suffer from the effect of defective draught. When the petticoat-pipe is just right, the flues will look uniformly clean inside, which can be ascertained by a close inspection of the smoke-box. In addition to making the engine lose the benefit of its full heating-surface, a badly arranged petticoat-pipe concentrates the draught so much that it tears the fire to pieces at one particular point; and the only resource for the man who wishes to keep up steam is to fire heavily, thereby preventing cold air from being drawn through the crevices.

## THE SMOKE-STACK.

The ordinary purpose of the smoke-stack to convey the smoke and exhausted gases to the atmosphere. If it is intended to perform its functions in a straightforward manner, it is made several inches' less diameter than the cylinders, and its highest altitude rises from 14 to 15 feet above the rail. The stack is a simple enough article to look at, yet a vast amount of inventive genius has been expended upon attempts to expand its natural functions. Attempts have been made to utilize it as an apparatus for consuming smoke, and hundreds of patents hang upon it as a spark-arrester. Patentees, in pushing their hobby, seem occasionally to forget that a locomotive requires some draught, as a means of generating steam; and stacks are frequently so hampered with patent spark-arresters that the means of making steam are seriously curtailed. Were it not for the danger of raising fires by spark-throwing, it would be more economical to use engines with clear smoke-stacks; and the extended front end, with open stack, is a good move in this direction.

## OBSTRUCTIONS TO DRAUGHT.

Every obstruction to free draught entails the use of strong artificial means to overcome it. The usual resort is contracted nozzles, which induce a sharp blast, and use up more fuel than would be required with an open passage to the atmosphere. Among the obstacles to free steaming, that come under the category of obstructed draught, may be placed a wide cone fast-



ened low, and netting with fine meshes. When the draught-passage is interrupted to a pernicious extent by spark-arresting appliances, their effects can be perceived on the fire when steam is shut off; for the flame and smoke prefer the fire-box door to the stack as a means of exit. Sometimes steam-making is hindered by the netting getting gummed up with spent lubricants and dirt from the cylinders. Cases occur where this gum has to be burnt off before free draught can be obtained. Waste soaked with coal-oil will generally burn off the objectionable coating.

#### THE EXTENDED SMOKE-BOX.

By this arrangement the spark-arresting device is transferred from the smoke-stack to the smoke-box, and the exhaust-steam escapes direct to the atmosphere, without meeting obstruction from a cone or netting. The netting is generally an oblong screen, extending from above the upper row of flues to the top of the extended smoke-box, some distance ahead of the stack. This presents a wide area of netting for the fire-gases to pass through. The draught through the flues is regulated by an apron or diaphragm-plate, extending downwards at an acute angle from the upper part of the flue-sheet. With the long exhaust-pipe used with the extended smoke-box, the tendency of the exhaust is to draw the fire-gases through the upper row of flues. The diaphragm-plate performs the same duties here, of regulating the draught through the flues equally, as the petticoat-pipe does with the diamond-stack. It is of great consequence,

for the successful working of the engine, that the draught should be properly regulated: otherwise there will be trouble for want of steam.

When an engine having an extended smoke-box does not steam properly, experiments should be made with the diaphragm fastened at different angles, till the point is reached where equal draught through the flues is obtained. Closing the nozzles, as a means of improving the steaming of such an engine, is certain to make matters worse.

#### STEAM-PIPES LEAKING.

The blowing of steam-pipe joints in the smoke-box is very disastrous to the steaming qualities of a locomotive. This has a double action against keeping up steam. All that escapes by leaking is so much wasted, and its presence in the smoke-box interrupts the draught.

If the steam-pipe joints are leaking badly, they can be heard when the fire-door is open and the engine working steam. Some experienced engineers can detect the action of leaky steam-pipe joints on the fire; but the safest way to locate this trouble is by opening the smoke-box door, and giving the engine steam.

#### DEFECTS OF GRATES.

Grates that are fitted so close as to curtail the free admission of air below the fire prevent an engine from steaming freely. The effect of this will be most apparent when the fire begins to get dirty. The tendency of locomotive-designers for many years has been

to increase the grate area as much as possible, so that sufficient air might easily be admitted to supply the combustion needs of heavy working engines. In many cases small grates might be made more efficient if they had a greater proportion of air-opening and less solid cast iron. I once knew of an engine's steaming being very seriously impaired by two or three fingers in one section of grate being broken off. The engine steamed well with a light fire, till, in dumping the fire at the end of a journey, the men knocked some of the fingers off. Next trip it seemed a different engine. Nothing but heavy firing would keep up an approach at working-pressure. I experimented with the petticoat-pipe without satisfaction, assured myself that no leaks existed among the pipes; the stack, with its connections, was faultless; and the engineer was puzzled. The defect was discovered by watching the effect of the blast upon the fire. Signs of air-drawing were often to be seen at the point where the broken fingers were. This was where the mischief lay. Too much cold air came through, unless the opening were bedded over by a heavy fire.

A drop-grate that did not close properly had a similar effect upon another engine which came under the author's notice; and a change, which shut the opening, effected a perfect remedy.

#### TEMPORARY CURES FOR LEAKY TUBES.

Leaky tubes or stay-bolts may sometimes be dried up temporarily by putting bran, or any other substance containing starch, in the feed-water. Care

must be taken not to use this remedy too liberally, or it will cause foaming. It is, however, a sort of granger resort, and is seldom tried except to help an engine to the nearest point where calking can be done.

#### GOOD MANAGEMENT MAKES ENGINES STEAM.

No engine steams so freely but that it will get short under mismanagement. The locomotive is designed to generate steam from water kept at a nearly uniform temperature. If an engine is pulling a train which requires the evaporation of 1,500 gallons of water each hour, there will be 25 gallons pumped into the boiler every minute. When this goes on regularly, all goes well; but if the runner shuts the feed for five minutes, and then opens it to allow 50 gallons a minute to pass through the pump, the best engine going will show signs of distress. Where this fluctuating style of feeding is indulged in,—and many careless runners are habitually guilty of such practices,—no locomotive can retain the reputation of doing its work economically.

#### INTERMITTENT BOILER-FEEDING.

The case of Fred Bemis, who still murders locomotives on a road in Indiana, is instructive in this respect. Fred was originally a butcher; and, had he stuck to the cleaver, he might have passed through life as a fairly intelligent man. But he was seized with the ambition to go railroading, and struck a job as fireman. He never displayed any aptitude for the business, and was a poor fireman all his time through

sheer indifference. But he had no specially bad habits; and, in the course of years, he was "set up." He had the aptitude for seeing a thing done a thousand times without learning how to do it. All his movements with an engine were spasmodic. Starting from a station with a roaring fire and full boiler, the next stopping-point loomed ahead; and to get there as soon as possible was his only thought. He would keep the reverse-lever in the neighborhood of the "corner," and pound the engine along. The pump would be shut off to keep the steam from going back too fast, till the water became low: then the feed would be opened wide, and the steam drowned down. In vain a heavy fire would be torn to pieces by vigorous shaking of the grates. The steam would not rally, and he would crawl into the next station at a wagon pace. A laboring blower and shaker-bar would resuscitate the energies of the engine in a few minutes if the flues and fire-box were not leaking too badly, and the injector would provide the water for starting on; but no experience of delay and trouble seemed capable of teaching Bemis the lesson how to work the engine properly. He soon became the terror of trainmen, and the boiler-makers worked incessantly on his fire-box. But he is still there, although he will not make an engineer if he runs for a century.

#### TOO MUCH PISTON CLEARANCE.

On one of our leading railroads a locomotive was rebuilt, and fitted with the extension smoke-box, which was an experiment for that road, and conse-

quently was looked upon with some degree of distrust. When the engine was put on the road, it was found that it did not steam satisfactorily. Of course, it was at once concluded that the draught arrangements were to blame; and experiments were made, with the view of adjusting the flow of gases through the tubes to produce better results. The traveling engineer of the road had charge of the job, and he proceeded industriously to work at locating the trouble. He tried everything in the way of adjusting the smoke-box attachments that could be thought of, but nothing that was done improved the steaming qualities of the engine. He then proceeded to search for trouble in some other direction. The result of his examination was the discovery that the engine was working with three-fourth inch clearance at each end of the cylinders. This, he naturally concluded, entailed a serious waste of steam so he had the clearance reduced to one-fourth inch. When the engine got out after this change, it steamed very satisfactorily, and the extension smoke-box is no longer in disrepute on that road.

This is no uncommon cause for waste of steam. In the last year of the nineteenth century, I knew of engines turned out by a first-class locomotive builder that had nearly one inch piston clearance at each end of the cylinder.

#### BADLY PROPORTIONED SMOKE-STACKS.

Mistakes are frequently made when the open stack is adopted, as is practicable with the extended smoke-box, of making the stack too wide for the exhaust.

This leads to deficiency of draught for the steam that is passing through the stack, because the steam does not fill the stack like a piston creating a clean vacuum behind it. Where an engine with an extended smoke-box fails to steam freely, attention should be directed to the proportion of stack diameter to the size of cylinders.

#### THE EXHAUST NOZZLES.

Locomotives, with their limited heating-surface, require intense artificial draught to produce steam rapidly. Many devices have been tried to stimulate combustion, and generate the necessary heat; but none have proved so effectual and reliable as contracted exhaust orifices. As the intermittent rush of steam from the cylinders to the open atmosphere escapes from the contracted openings of the exhaust-pipe, it leaves a partial vacuum in the smoke-box, into which the gases from the fire-box flow with amazing velocity. As the area of the exhaust nozzles is increased, the pressure of steam passing through becomes lessened, and the height of the vacuum in the smoke-box is decreased. Consequently, with wide nozzles, the velocity of the gases through the flues is slower than with narrow ones; for there is less suction in the smoke-box to draw out the fire products: and, where the gases pass slowly through the flues, there is more time given for the water to abstract the heat. Any change or arrangement which will retain the gases of combustion one-tenth of a second longer in contact with the heat-extracting surfaces, will won-

derfully increase the evaporative service of a ton of coal. Experiments with the pyrometer, an instrument for measuring high temperatures, have shown that the gases passing through the smoke-box vary from 500 degrees up to 1000 degrees Fahrenheit; and they show that increase of smoke-box temperature keeps pace with contracted nozzles. From this, engineers can understand why lead gaskets do not keep blower-joints in a smoke-box tight, the melting-point of lead being 627 degrees.

Inordinately contracted nozzles are objectionable in another way. They cause back pressure in the cylinders, and thereby decrease the effective duty of the steam. Double nozzles are preferable to single ones; because with the latter the steam has a tendency to shoot over into the other cylinder, and cause back-pressure.

Engineers anxious to make a good record, try to run with nozzles as wide as possible. Contracted nozzles destroy power by back pressure: they tear the fire to pieces with the violent blast, and they hurry the heat through the flues so fast that its temperature is but slightly diminished when it passes into the atmosphere. The engineer who, by intelligent care, reduces his smoke-box temperature 100 degrees, is worthy to rank as a master in his calling.

The other day an engineer came into the round-house, and said, "You had better put  $3\frac{1}{2}$ -inch nozzles in my engine: I think she will get along with that increase of size." He had been using  $3\frac{1}{4}$ -inch nozzles. The change was accordingly made. When he re-



turned from the next trip, he expressed a doubt about the advantage of the change. But it happened that his own fireman was off, and a strange man was sent out, who, although a good fireman, failed to keep up steam satisfactorily. On the following trip, however, the fireman who belonged to the engine, returned, and found no difficulty in getting all the steam required. But this fireman is one who would stand far up among a thousand competitors. Considerable practice and intelligent thoughtfulness, combined with unfailing industry, have developed in this man an excellence in fire management seldom attained. He follows a unique system, which seems his own. It is the method of firing light carried to perfection. His coal is all broken down fine, and lies within easy reach. His movements are cool and deliberate, no hurry, no fuss. When he opens the door, his loaded shovel is ready to deposit its cargo over the spot which a glance shows him to be the thinnest portion of the fire. On the parts of the run where the most steam is needed, he fires one shovelful at brief intervals, keeping it up right along. In this way the steam never feels the cooling effect of fresh fire, for the contents of the fire-box are kept nearly uniform. This plan is the nearest possible approach to the work done by the automatic stoker, which has been made an entire success with stationary boilers and is a thorough preventive of smoke.

## CHAPTER IX.

### SHORTNESS OF WATER.

#### TROUBLE DEVELOPS NATURAL ENERGY.

TROUBLE and affliction are known to have a purifying and elevating effect upon human character; difficulties encountered in the execution of work, develop the skill of the true artisan; and trouble on the road, or accidents to locomotives, furnish the engineer with opportunities for developing natural energy, ingenuity, and perseverance, if these attributes are in him, or they publish to his employers his lack of these important qualities.

One of the most serious sources of trouble that an engineer can meet with on the road, is shortness of water.

#### SHORTNESS OF WATER A SERIOUS PREDICAMENT.

Deficiency of steam with a locomotive that is expected to get a train along on time, is a very trying condition for an engineer to endure. But a more trying and more dangerous ordeal, is want of water. Where steam is employed as a means of applying power, water must be kept constantly over the heat-

ing-surfaces while the fire is incandescent, or their destruction is inevitable. With a boiler which evaporates water rapidly, and in such large quantities as that of the locomotive, the most perfect feeding apparatus is necessary. Nearly all locomotives are well supplied in this respect. Good injectors provide the engineer with excellent appliances for feeding the boiler under ordinary circumstances. But conditions sometimes occur where the most reliable of injectors fail to force water into the boiler.

#### HOW TO DEAL WITH SHORTNESS OF WATER.

When from any cause he finds the boiler getting short of water, the engineer should resort to all known methods within his power to overcome the difficulty, by removing the obstacle that is preventing the feeding apparatus from operating. But, while doing so, the safety of his fire-box and flues should not be overlooked for a moment. The utmost care must be taken to quench the fire before the water gets below the crown-sheet. This can be performed most effectually by knocking the fire out; but sometimes the temporary increase of heat, occasioned by the act of drawing the fire, is undesirable; and, in such a case, the safest plan is to dampen the fire by throwing wet earth, or fine coal saturated with water, upon it. Or a more urgent case still may intervene, when drenching the fire with water is the only means of saving the sheets from destruction. This should be a last resort, however; for it is a very clumsy way of saving the fire-box, and is liable to do no small amount of

mischief. Cold water thrown upon hot steel sheets, causes such sudden contraction, that cracks, or even rupture, may ensue.

#### WATCHING THE WATER-GAUGES.

As "burning his engine" is the greatest disgrace that can professionally befall an engineer, every man worthy of the name guards against a possibility of being caught short of water unawares, by frequent testing of the gauge-cocks. It is not enough to have a good-working water-glass. If an engineer is ambitious to avoid trouble, he runs by the gauge-cocks, using the glass as an auxiliary. Careful experiments have demonstrated the fact that the water-glass, working properly, is a more certain indication of the water-level than gauge-cocks; for, when the boiler is dirty, the water rises above its natural level, and rushes at the open gauge-cock. This can be proved when water is just below a gauge-cock level. If the cock is opened slightly, steam alone passes out; but when the full opening is made water comes. But water will not come through a gauge-cock unless the water-level is in its proximity; and an engineer can tell, when his gauge shows a mixture of steam, that the water shown is not to be relied upon. It is not "solid." On the other hand, a water-glass out of order sometimes shows a full head of water when the crown-sheet is red-hot.

WHAT TO DO WHEN THE TENDER IS FOUND  
EMPTY BETWEEN STATIONS.

The most natural cause for injectors ceasing to work is absence of water from the tender. This condition comes round on the road occasionally, where engineers neglect to fill up at water-stations, or where there are long runs between points of water-supply. When an engineer finds himself short of water, and the means of replenishing his tank too distant to reach, even with the empty engine, he should bank or smother the fire, and retain sufficient water in the boiler to raise steam on when he has been assisted to the nearest water tank. This will save tedious delay, especially where an engine has no pumps. Occasionally, from miscalculations or through accidents, the fire has to be quenched, and insufficient water is left in the boiler to start a fire on safely. In this event, buckets can be resorted to, and the boiler filled at the safety-valves, should there be no assistance or means of pumping up. Every possible means should be exhausted to get the engine in steam before a runner requests to have his engine towed in cold.

A TRYING POSITION.

I once knew a case where an engineer inadvertently passed a water-tank without filling his tender. He had a heavy train, and was pushing along with a heavy fire, on a severe, frosty night, when every creek and slough by the wayside was lost in heavy ice. Presently his pump stopped working, and he spent some

time trying to start it before he discovered that the tender was empty. By the time this fact became known, his boiler-water was low, and a heavy fire kept the steam screaming at the safety-valves. He had no dump-grate, and the fire was too heavy to draw. It seemed a clear case of destroying the fire-box and flues. But he was a man of many resources. First, he tried to get water through the gauge-cock—he had only one gauge—to quench the fire, but found the plan would not work. Then he filled up the fire-box nearly to the crown-sheet with the smallest coal on the tender, and partly smothered the fire. He then partly opened the smoke-box door, and started for the water-station. After getting the engine going, he hooked the reverse-lever in the center and kept the throttle wide open, to make the most of the steam-supply. He saved his engine.

#### WATCHING THE STRAINERS.

When the top of a tank is in bad order and permits cinders and small pieces of coal to fall through rivet-holes or through seams, the engineer may look out for grief with his pumps or injectors. On the first signs of the water failing, he should examine the strainers; and he will probably find that these copper perforations, which stand like wardens guarding the safety of the pumps and injectors, have accumulated a mass of cinders that obstructs the flow of the water.

## INJECTORS.

Although the injector is not theoretically so efficient as a good pump, practically it has proved itself the best means of feeding water to locomotive boilers that has ever been tried. When a well-made injector is used regularly, it is more reliable than any form of pump, is more easily examined and repaired when it gets out of order, is less liable to freeze or to sustain damage from accidental causes, and it regulates the quantity of water required as well as the ordinary pump, and better than any pump actuated by the machinery of the engine, when the speed of a train is irregular. The injector also possesses the important advantage that it raises the temperature of the feed-water to approach the temperature of the boiler, thereby avoiding shocks and strains to metal that very cold water is likely to impart.

So long as injectors were imperfectly understood, and were used with no regularity, they retained the name of being unreliable; but so soon as they began to be made the sole feeding medium for locomotive boilers, they had to be worked regularly, and kept in order, which quickly made their merits recognized.

## INVENTION OF THE INJECTOR.

The boiler-feed injector was invented by Henri Giffard, an eminent French scientist and aeronaut. Its successful action was discovered during a series of experiments, made with the view of devising light machinery that might be used to propel balloons.

Although Giffard designed the most perfect balloon that was ever constructed, the injector was not used upon it; and the invention was laid aside and almost forgotten. During the course of a sea-voyage, Giffard happened to meet Stewart of the engineering firm, Sharp, Stewart & Co., of Manchester, England. In the course of a conversation on the feeding of boilers, Giffard remembered his injector, and mentioned its method of action. Stewart was struck with the simplicity of the device, and undertook to bring it out in England, which he shortly afterwards did, representing the interests of the inventor so long as the original patents lasted. By his advice, William Sellers & Co., of Philadelphia, were given control of the American patents. Seldom has an invention caused so much astonishment and wild speculation among mechanics, and even among scientists, as the injector did for the first few years of its use. Scientists were not long in discovering the philosophy of the injector's action, but that knowledge spread more slowly among mechanics. It was regarded as a case of perpetual motion—the means of doing work without power, or, as Americans expressed it, by the same means a man could raise himself by pulling on his boot-straps.

#### PRINCIPLE OF THE INJECTOR'S ACTION.

Although the mechanism of the injector is very simple, the philosophy of its action is not so easily understood as the principles on which a pump raises water and forces it into the boiler. On beginning to investigate the action of the injector, it appears a phys-



ical paradox, the finding that steam at a given pressure leaves a boiler, passes through several tortuous and contracted passages, raises several check-valves, and then forces water into the boiler against a pressure equal to that which the steam had when it first began the operation. At first acquaintance, the operation looks as if it had a strong likeness to perpetual motion, but closer investigation will show that the steam which raises and forces the water by passing through an injector performs mechanical work as truly as the steam that pushes a piston which moves a pump-plunger. A current of any kind, be it steam, air, water, or other matter, has a tendency to induce a movement in the same direction of any body with which it comes in contact. Thus, we are all familiar with the fact that a current of air called wind, passing over the surface of a body of water, sets waves in motion, and dashes the water high up on the shore away above its original level. In the same way a jet of steam moving very rapidly, when injected into a body of water under favorable conditions, imparts a portion of its motion to the water, and starts it with momentum sufficient to overcome a pressure even higher than the original pressure of the steam. The locomotive blast, blowers, steam siphons, steam jets, jet exhausters, vacuum ejectors, and argand burners, are all common instances of the application of the principle of induced currents.

#### VELOCITY OF STEAM AND OF WATER.

At a boiler-pressure of 140 pounds per square inch steam passes into the atmosphere with a velocity of

1920 feet per second. When steam at this speed strikes like a lightning-flash into the tubes of the injector, it becomes the ram which forces the water towards the boiler; but its power is opposed by the tendency of the water inside the boiler to escape through the check-valve. The velocity with which water will flow from a vessel is known to be equal in feet to the square root of the pressure multiplied by 12.19. Accordingly, in the case under consideration, the water inside of the boiler would tend to escape at a speed of 144 feet per second. This represents the resistance at the check-valve. The mechanical problem, then, to be worked out by the injector is to transform the energy of hot steam moving at a high velocity into the momentum possessed by a heavier and colder mass of water. In the operation the steam yields up a portion of its heat and the greater part of its velocity, but it keeps a current of water flowing fast enough to overcome the static resistance at the check-valve.

#### TEMPERATURE OF INJECTED WATER.

A common delivery temperature of the water forced through an injector is 160 degrees Fahr. Taking the feed-water at 55 degrees Fahr., we find that the steam used in operating the injector imparts 105 degrees Fahr. to the feed-water before putting it into the boiler. One pound of steam at 140 pounds boiler-pressure contains 1224 heat units reckoned above zero. When the hot steam speeding at a high velocity

strikes the feed-water, part of the heat is converted into the mechanical work required to put the water in motion, but there still is left heat sufficient to raise about 11 pounds of water to the temperature of 160 degrees. One pound of steam, therefore, communicates to 11 pounds of water the motion required for overcoming the resistance encountered at the check-valve. The steam moving at a speed of 1920 feet per second having imparted motion to a body eleven times its own weight, itself in the meantime having become a portion of the mass, the velocity of the feed-water would be  $1920 \div 12 = 170$  feet per second. When the reduction of speed due to friction of the pipes and other resistances is considered, there still remains momentum enough in the water to raise the check-valve.

Although 160 degrees is about the average heat of the water delivered by lifting injectors, instruments can be designed so that they will heat the water much higher. With non-lifting injectors the feed-water is nearly always delivered at a higher temperature than with the other kind.

#### ELEMENTARY FORM OF INJECTOR.

There are numerous forms of injectors in use, but they are all developments of the elementary arrangement of parts shown in the annexed illustration, Fig. 1. Steam at a high velocity passes from the boiler into the tube *A*, and striking the feed-water at *B*, is itself condensed, but imparts momentum to the water to

send it rushing along into the delivery-pipe *E* with sufficient force to raise the check-valve against the pressure inside and pass into the boiler. As the current of water could not be started into rapid motion against the constant pressure of the check-valve, an

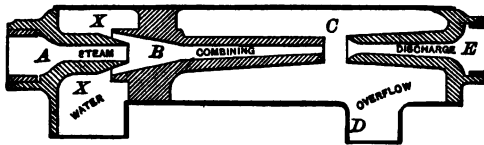

FIG. 1.

overflow opening is provided in the injector, through which the water can flow unchecked till the necessary momentum is obtained, when the overflow-valve is closed.

In a lifting injector the parts are so designed that, in starting, a jet of steam passes through the combining tube *B* at sufficient velocity to create a vacuum in the water-chamber *XX*, and the water is drawn into this place from the feed-pipe as if by the suction of a pump. The steam-jet then striking the water starts it into motion. If too much steam is admitted for the quantity of water passing, air will be drawn in through the overflow opening, mixing with the water and reducing its compactness, while some uncondensed steam will pass through with the water. This will reduce the force of impact of the feed-water upon the boiler check, and when it becomes so light that the momentum of feed-water is no greater than the resistance inside the boiler, the injector will break. On the other hand, when the quantity of water supplied is too great for

the steam to put into high motion, part will escape through the overflow-valve. In some forms of injectors, separate appliances are used for raising the water from the forcing chamber to the source of supply.

As the successful operating of the injector is dependent on the feed-water promptly condensing the steam which supplies the power, water of a very high temperature cannot be fed by an injector. A certain amount of live steam must be condensed by the feed-water to impart the momentum necessary to make the latter overcome the resistance at the check-valve. When the feed-water becomes hotter than 100 degrees Fahr. a point is soon reached where it takes such a large body of water to condense the steam that there is not the required velocity generated to force the feed-water into the boiler.

All deviations from the elementary form of injector shown are made for the purpose of extending the action of the instrument under varied conditions, for making it work automatically under different pressures of steam, and for increasing its capacity for raising the water to be used above its natural level.

#### CARE OF INJECTORS.

When an engineer finds that an injector refuses to work, his first resort should be the strainer. That gets choked with cinders or other impurities so frequently that no time should be lost in examining it. One day when I was running a round-house, an engineer came in breathless, with the information that his engine was

blocked in the yard, and he must dump his fire, as he could not get his injector to work. The thermometer stood at twenty degrees below zero, and an Iowa blizzard was blowing; so the prospect of a dead engine in the yard meant some distressingly cold labor. I asked, the first thing, if he had tried the strainer; and his answer was that the strainer was all right, for the injector primed satisfactorily, but broke every time he put on a head of steam. I went out to the engine, and had the engineer try to work the injector. By watching the overflow stream, I easily perceived that the injector was not getting enough water, although it primed. An examination showed that the strainer was full of cinders, and the injector went to work all right as soon as the obstruction to the water was removed.

#### THE MOST COMMON CAUSES OF DERANGEMENT.

Sand and cinders are the most common causes of failure with injectors, as they are indeed with all water-feeding apparatus. A very common cause of failure of injectors is leakage of steam through throttle-valve or check-valve, keeping the tubes so hot that no vacuum can be formed to make it prime. A great many injector-checks have been turned out too light for ordinary service, while others are made in a shape that will always leave the valve away from the seat when they stop working. Then the engineer has to run forward and pound the check with a hammer to keep the steam from blowing back, and that soon ruins the casting. Check-valves set in a horizontal position are worthless with water that contains grit.

## HOW TO KEEP AN INJECTOR IN GOOD ORDER.

To preserve a good working injector, the engineer should see that the pipes and joints are always perfectly tight. Of course it is difficult to keep them tight when they are subjected to the continual jars a locomotive must stand; but injectors cannot be depended on where there is a possibility of air mixing with the water. Leaky joints or pipes are particularly troublesome to lifting injectors; for air passes in, and keeps the steam-jet from forming a vacuum. At first the injector will merely be difficult to start; but as the leaks get worse there will be no starting it at all. Then, the air mixing with the water is detrimental to the working of all injectors, as its tendency is to decrease the speed of the water. The compact molecules of water form a cohesive body, which the steam can strike upon with telling force to keep it in motion. When the water is mixed with air it lacks the element of compactness, and the steam-jet strikes a semi-elastic body which does not receive momentum readily. This mixture of steam and air does not act solidly on the check-valve, but makes the water pass in with a bubbling sound, as if the valve were moving up and down; and the stream of water breaks very readily when it is working in this way.

## COMMON DEFECTS.

As maintaining unbroken speed on the water put in motion is the first essential in keeping an injector in good working order, anything that has a tendency to

reduce that speed will jeopardize its action. A variety of influences combine to reduce the original efficiency of an injector. Those with fixed nozzles are constructed with the orifices of a certain size, and in the proportion to each other which experiment has demonstrated to be best for feeding with the varied steam-pressures. When these orifices become enlarged by wear the injector will work badly, and nothing will remedy the defect but new tubes. The tubes sometimes get loose inside the shell of the injector, and drop down out of line. The water will then strike against the side of the next tube, or on some point out of the true line, scattering it into spray which contains no energy to force itself into the boiler. A machinist examining a defective injector should always make sure that the tubes are not loose. Injectors suffering from incrustated water-passages will generally work best with the steam low. In districts where the feed-water is heavily charged with lime salts, it is common for injectors to get so incrustated that the passages are almost closed.

Joints about injectors that are kept tight by packing must be closely watched. Many an injector that failed to work satisfactorily has been entirely cured by packing the ram-gland.

#### CARE OF INJECTORS IN WINTER.

During severe frosty weather an injector can be kept in order without danger of freezing; but it needs constant watching and intelligent supervision.

To keep an injector clear of danger from frost, it should be fitted with frost-cocks so that all the pipes



can be thoroughly drained. Bends in the pipes, where water could stand, should be avoided as far as possible; and where they cannot be avoided, the lowest point should contain a drain-cock.

To operate an injector successfully, thoughtful care is requisite on the part of the engineer; and where this is given, the injector will prove itself a very economical boiler-feeder.

The injectors principally used in American locomotives are the Sellers, the Nathan, the Rue Little Giant, and the Metropolitan. All are good reliable boiler-feeders, and all are made to wear well under the rough service met with on locomotives.

#### THE SELLERS INJECTOR.

When the Giffard injector was first introduced into this country by William Sellers & Co., Philadelphia, it was a rather defective boiler-feeder; but that firm effected great improvements and led the way for making the injector the popular boiler-feeder it is to-day. They made the instrument self-adjusting, and improved its design so that it would feed automatically however much the pressure of the boiler varied, and finally they perfected it so that, should anything happen to interrupt its working, it would automatically restart itself. The latest development of the injector is shown by a sectional view in Fig. 2 (see next page).

This instrument will start at the lowest steam-pressures with water flowing to it, and will lift the water promptly even when the suction-pipe is hot. At 10 pounds steam-pressure it will lift the water 2

feet; at 30 pounds, 5 feet; and at all ordinary pressures, say 60 pounds and over, it will lift from 12 to 18 feet. It can be used as a heater for the water supply by simply closing the waste-valve and pulling out the steam-lever.

By reference to the cut it will be seen that this injector consists of a case *A* provided with a steam-inlet *B*, a water-inlet *C*, an outlet *D* through which

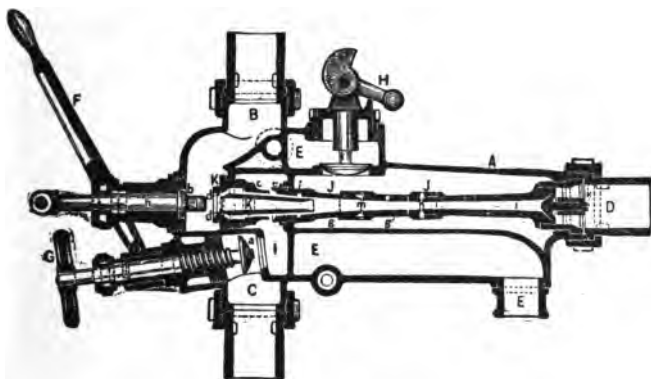

FIG. 2.—SELLERS.

the water is conveyed to the boiler, an overflow opening *E*, a lever *F* by which to admit steam, stop and start its working, a hand-wheel *G* to regulate the supply of water, and an eccentric lever *H* to close the waste-valve when it is desired to make a heater of the injector. Its operation is as follows:

The water-inlet *C* being in communication with water supply, the valve *a* is open to allow the water to enter the chamber *I*. Steam is admitted to the chamber *B*, and the lever *F* is drawn out to lift the valve *b*

from its seat and permit the steam to enter the annular lifting steam-nozzle *c* through the holes *d d*. The steam issuing from this nozzle passes through the annular combining tube *e* and escapes from the instrument partly through the overflow opening *f* and partly through the overflow openings provided in the combining tube *g g'*, through the overflow chamber *J* and passage *E E*, and produces a strong vacuum in the water chamber *I* which lifts the water from the source of supply, and the united jet of steam and water is, by reason of its velocity, discharged into the rear of the receiving end of the combining tube *g*. The further movement of the lever *F* withdraws the spindle *h* until the steam-plug *i* is out of the forcing nozzle *K*, allowing the steam to pass through the forcing nozzle *K* and come in contact with the annular jet of water which is flowing into the combining tube around the nozzle *K*. This jet of water has already a considerable velocity, and the forcing steam jet imparts to it the necessary increment of velocity to enable it to enter the boiler through the delivery tube *j* and boiler check *k*.

If from any cause the jet should be broken—say from a failure in the water supply—the steam issuing from the forcing nozzle *K* into the combining tube *g* will escape through the overflows *m* and *n* and intermediate openings with such freedom that the steam, which will return through the annular space formed between the nozzle *K* and combining tube *g*, and escape into the overflow chamber through the opening *f*, will not have sufficient volume or force to interfere with

the free discharge of the steam issuing from the annular lifting steam-nozzle and escaping through the same overflow  $F$ , and hence the lifting steam-jet will always tend to produce a vacuum in the water-chamber  $I$ , which will again lift the water when the supply is renewed, and the combined annular jet of steam and water will be forced into the combining tube  $g$  against the feeble current of steam returning, when the jet will again be formed and will enter the boiler as before. In actual practice on a locomotive the movement of the lever  $F$  in starting the injector is continuous.

#### NATHAN MFG. CO.'S IMPROVED MONITOR INJECTOR.

One of the most successful and enduring injectors in use is the Monitor, the distinguishing feature of which originally was that the injector is constructed with fixed nozzles, that insure great durability, combined with certainty of action. The injector shown in Fig. 3 is an improvement on the old Monitor, the radical change being that this injector is operated by a single lever. Any one who has studied the operation of the injector already described will have no difficulty in perceiving how the new Monitor works. It will be seen that steam is admitted from the top to the tube that forms the body of the injector, and the water from below. To start the injector, the water-valve  $W$  is opened. The main lever  $S$  is then pulled out a short distance to lift the water; when the water begins to escape through the overflow the lever  $S$  is steadily drawn back, which puts the injector working

at its maximum power. The quantity of feed required is graduated by the valve *W*.

When it is desired to use the injector as a heater, close the valve *H* and pull out the lever *S* all the way, At other times the valve *H* must be kept open.

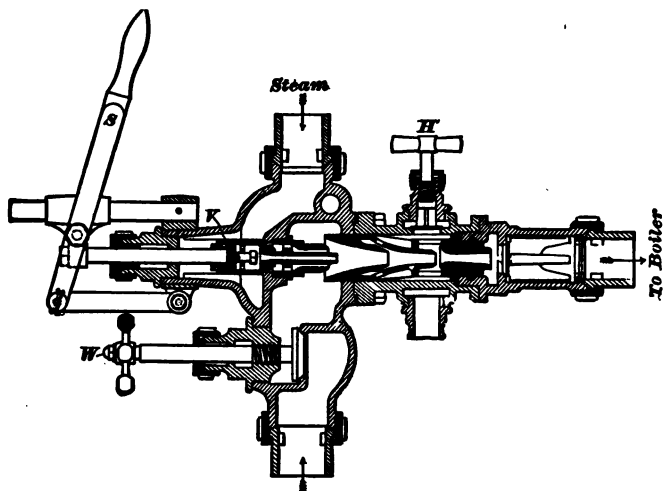

FIG. 3.—NATHAN'S MONITOR.

With a boiler pressure of 30 pounds this injector will lift the water 5 feet, and at ordinary working pressure the steam will have power to lift the water to a height not likely to arise in locomotive practice.

#### LITTLE GIANT INJECTOR.

This injector, made by the Rue Manufacturing Co., is a highly efficient boiler-feeder, and a very simple apparatus. The construction is clearly seen in the engraving. A unique feature about this injector is

the movable combining tube adjusted by a lever, causing the feed to be exactly suited to the service. Moving the lever towards *A* tends to cut off the feed, and moving towards *B* increases it. To work the injector, the combining tube lever is set in position to admit sufficient water to condense the steam from the starting valve. The starting valve is then opened

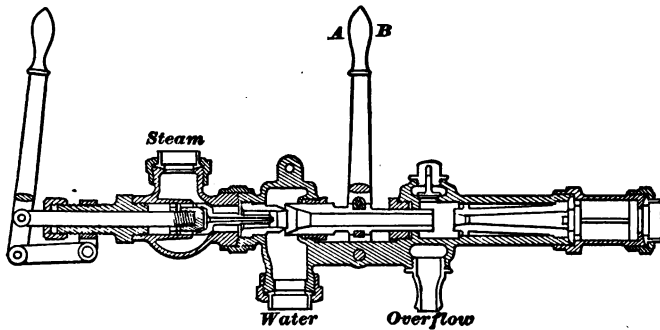

FIG. 4. LITTLE GIANT.

slightly till the water begins to escape from the overflow, when it is opened full. The feed is then regulated by the combining tube lever. To use this injector as a heater, the overflow is closed by the combining tube being moved up against the discharge, and opening the starting valve sufficiently to admit the quantity of steam required.

The Metropolitan 1898 locomotive injector is a double-tube injector, and great care has been taken in designing same to have the chambers and the form of the shell such as to procure the greatest possible steam range. This injector consists of two sets of tubes,—a set of lifting tubes, which lifts the water and delivers it to the forcing set of tubes under pres-

sure, which in turn forces the water into the boiler. The lifting set of tubes act as a governor to the forcing tubes, delivering the proper amount of water required for the condensation of the steam, thus enabling the injector to work *without any adjustment* under a great range of steam pressure, handle very hot water, and

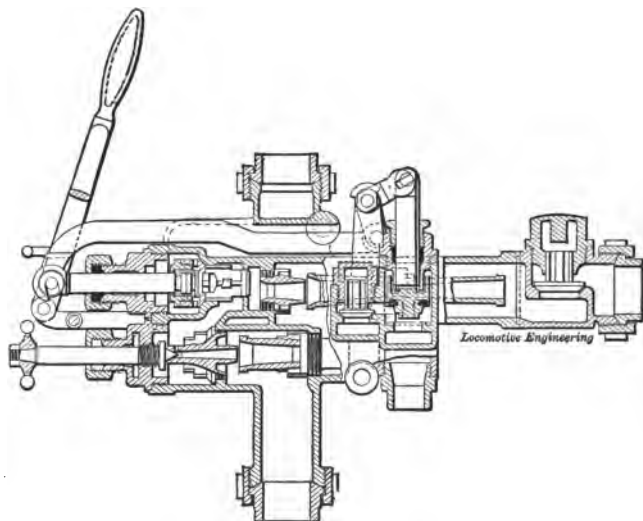

FIG. 5.—METROPOLITAN.

admit of the capacity being regulated for light or heavy service under all conditions.

The Metropolitan 1898 locomotive injector starts with 30 lbs. steam pressure, and without any adjustment of any kind will work at all steam pressures up to 300 lbs.; in fact, at all steam pressures and under all conditions its operation is the same, and it is impossible for part or all of the water to waste at the overflow.

## CHAPTER X.

### BOILERS AND FIRE-BOXES.

#### CARE OF LOCOMOTIVE BOILERS.

THE present tendency of steam engineering, in the effort to increase the work performed in return for every pound of fuel consumed, is to employ steam of very high pressure. The greater the initial pressure of the steam, the greater are the advantages to be derived from its expansive principle. To resist successfully the enormous aggregate of pressure to which locomotive boilers are subjected, a well-constructed, strong boiler is absolutely necessary; and the various railroad companies throughout the country meet the required conditions in an admirable manner, as is evidenced by the remarkable exemption of such boilers from serious accidents. Although the locomotive is the most intensely pressed boiler in common use, that supreme disaster, an explosion, is of rare occurrence, considering the vast number of boilers doing service all over the continent. This result is due to constant care in the construction, in the maintenance, and in the management of the locomotive boiler. Like the conservation of liberty, eternal vigilance is the price of safety.



## FACTOR OF SAFETY.

There is perfect safety in using a boiler so long as a good margin of resisting power is maintained above the tendency within to tear the sheets asunder. This margin is very low for locomotive boilers generally, hence the greater necessity for care in maintenance and management. Years ago the mechanical world established by practice a rule making one-fifth of the ultimate strength of a boiler its safe working-pressure. That is, a boiler carrying 200 pounds working-pressure should be capable of withstanding a tension of 1000 pounds to the square inch before rupture ensues. Locomotive practice in this country does not provide much more than half of that margin of safety. When deterioration or accident reduces this margin, danger begins.

## DIFFERENT FORMS OF LOCOMOTIVE BOILERS.

A great variety of boilers has been tried at various times for locomotives, but the searching tests of experience and the survival of the fittest have led our designers to make use of about four forms. The most popular form is the wagon-top boiler, which has an enlargement of the shell over the fire-box and is sloped gradually to the diameter of the barrel. What makes this form of boiler popular is that it provides liberal space for steam above the fire-box, and this tends to supply the throttle-valve with steam that is dry and free from water.

The straight boiler, which has no wagon-top, is popular among some superintendents of motive power because it is said to be a particularly strong form of boiler.

The Belpaire boiler is a favorite on some roads. Its chief merit is that the fire-box crown and outside shell are made flat and they can be bound together with stay-bolts that are under straight tension.

#### ANTHRACITE-BURNING BOILERS.

Anthracite coal burns so slowly that a large grate area is necessary to burn the fuel fast enough to make the required quantity of steam. That is why the peculiarity of anthracite-burning locomotives is to have huge fire-boxes.

Ever since railroad operating in the State of Pennsylvania began inventors have been laboring to design forms of fire-boxes that would provide greater grate area than was possible with a fire-box curtailed in breadth by the width of frames and in length by the spread of the driving-axes. These contracted conditions were first overcome by Ross Winans, who put a long overhanging fire-box behind the back driving-wheels. The same practice was followed by Zerah Colburn in the designing of locomotives for the Erie; but he went further than Winans and spread the fire-box outside the line of the frames. He was the originator of what is now generally known as the Wootten fire-box. This name originated through patents granted to John E. Wootten of the Philadelphia & Reading for the combination of a wide fire-box ex-

tending outside of the frames, a combustion-chamber and a brick wall therein.

That kind of fire-box has been found very useful for burning anthracite slack. Outside of the Reading system most of the wide fire-boxes, or "Mother Hubbards," as trainmen call them, have no combustion-chamber, and therefore the right name for them would be Colburn fire-boxes.

#### STAY-BOLTS.

A very important thing about a locomotive boiler is getting the fire-box secured in such a way that the least possible stresses are set up to tear the fire-box and the boiler-shell apart. The fire-box must necessarily be made with flat surfaces. The steam-pressure inside tends to push the outside and inside of the fire-box apart, and this has to be resisted by stay-bolts which are generally placed about four inches apart. The continual changes of temperature expands and contracts the inside of the fire-box more than the outside, and this movement is resisted by the stay-bolts. The continual moving action gradually weakens these stay-bolts, until a time comes when they break. Constant vigilance is necessary to detect broken stay-bolts. It is safe to say that ninety per cent of locomotive-boiler explosions are due to broken stay-bolts. This will indicate how important it is that unceasing attention should be devoted to detecting the deterioration of stay-bolts. The only sure preventive of accidents from broken stay-bolts is to have hollow stay-bolts,

or solid ones drilled from the outside deep enough to cause leakage when fracture takes place.

#### BOILER EXPLOSIONS.

Certain mechanical empirics and impractical quasi-scientists have at various times attempted to surround the cause of boiler explosions with a halo of mystery. But our most accomplished scientists who have made the subject a special study, and our best mechanical experts who have devoted years of patient experiment and research to the investigation of boiler explosion, attribute the terrible phenomenon to intelligible causes alone. The conclusions of the practical part of the mechanical world are well summed in one sentence in one of the annual reports of the Master Mechanics' Association. It says, "Explosions originate from over-pressure: it matters not whether the whole boiler, or a portion of it, is too weak to resist the pressure."

#### PRESERVATION OF BOILERS.

The preservation of a boiler depends very much upon the care and attention bestowed upon it by the engineer, and no other person is so much interested in its safety. To prevent undue strains from being put upon the boiler, the engineer should see that the safety-valves and the steam-gauge are kept in proper order. To secure this, the steam-gauge should be tested at least once a month. The rule established on well-conducted roads, prohibiting engineers from

interfering with safety-valves, is a very judicious one; and no persons are more interested in its strict observance than the engineers themselves.

#### CAUSING INJURY TO BOILERS.

Some men are idiotic enough to habitually screw down safety-valves, that the engine may be able to overcome heavy grades without doubling. This is criminal recklessness, and all trainmen are interested in its suppression. Low water has often been blamed falsely as the cause of disaster to boilers; a theory having prevailed that permitting the water to become low led to the generation of an explosive gas which no sheet could withstand. That theory was exploded long ago; but, nevertheless, it is certain that low water paves the way for explosions by deteriorating the fire-box sheets, and destroying stay-bolts. A careful engineer watches to prevent his engine from getting "scorched" even slightly; for the smallest scorching may yield a harvest of trouble, even after many days. The danger of scorching is most imminent when an engine is foaming badly from the effects of impurities in the feed-water or in the boiler. At such a time the water rises so lavishly with the steam, that the gauges are no indication of the true water-level. The steam must be shut off to find the true level of the water. Where this trouble is experienced, the engineer should err on the safe side, even though untold patience is needed to work the engine along with the boiler full of water.

## DANGERS OF MUD AND SCALE.

Mud within the boiler, and scales adhering to the heating-surface, are dangerous enemies to the preservation of boilers; and engineers should strive to prevent their evil effects by rooting them out so far as practicable. Much can be banished by washing out frequently; and scale can, to some extent, be prevented by selecting the softest water on the road. If water in a tank is so hard that it makes soap curdle instead of lather when a man attempts to wash with it, that tank should be avoided as far as possible.

## BLOWING OFF BOILERS.

The sudden cooling down of boilers, by blowing them off while hot, is a most pernicious practice, which is responsible for many cracked sheets and broken stay-bolts. It also tends to make a boiler scale the heating-surfaces rapidly. Every time a boiler is blown out hot, if the water contains calcareous solution, a coat of mud is left on the heating-surfaces, which dries hard while the steel is hot. If a piece of scale taken from a boiler periodically subjected to this blowing-out process be closely examined, it will be found to consist of thin layers, every one representing a period of blowing off just as plainly as the laminæ of our rocks indicate the method of their formation. When a boiler must be cooled down quickly for washing out or other purposes, the steam should be blown off and the boiler gradually filled up with water. Then open the blow-off cock, and keep

water running in about as fast as it runs out until the temperature gets even with the atmosphere. The boiler may now be emptied without injury. Or another good plan is to blow off about two gauges of water under a pressure of forty or fifty pounds of steam, then cool down the boiler gradually, to prepare for washing.

Although the dangers of blowing off hot boilers, and then rushing in cold water to wash out, are well known and acknowledged, yet the practice is still followed on many roads where more intelligent action might be expected.

#### OVER-PRESSURE.

Should it happen from any cause that the safety-valves fail to relieve the boiler, and the steam runs up beyond a safe tension, the situation is critical; but the engineer should not resort to any method of giving sudden relief. To jerk the safety-valve wide open at such a time is a most dangerous proceeding. A disastrous explosion lately occurred to a locomotive boiler from this cause. The safety-valves had been working badly; and, while the engine was standing on a side track, they allowed the steam to rise considerably above the working-pressure. When the engineer perceived this, he threw open the safety-valve by means of a relief-lever, and the boiler instantly went into fragments. Cases have occurred where the quick opening of a throttle-valve has produced a similar result. The proximate cause of such an accident was the violent motion of water and steam within the

boiler, induced by the sudden diminution of pressure at one point; but the real cause of the disaster was a weak boiler,—a boiler with insufficient margin of resisting power. The weakest part of a boiler is its strongest point. This may seem paradoxical, but a moment's reflection will show that the highest strength of a boiler merely reaches to the point where it will give out. Hence engineers should see that a boiler is properly examined for unseen defects so soon as signs of distress appear. Leaky throat-sheets or seams, stay-heads dripping, or incipient cracks, are indications of weakness; and their call should be attended to without delay.

#### RELIEVING OVER-PRESSURE.

When an engineer finds the steam rising beyond a safe pressure, he should reduce it by opening the heaters, starting the injectors, dampening the fire, or even by blowing the whistle. The whistle offers a convenient means of getting rid of superfluous steam, and its noise can be stopped by tying a rag between the bell and the valve-opening.

#### BURST TUBES.

Should any boiler attachment, such as a check-valve or blow-off cock, blow out or break off, no time should be lost in quenching the fire. That is the first consideration. A burst tube will generally save an engineer the labor of extinguishing the fire. In this case an engineer's efforts should be directed to reducing the pressure of steam as quickly as possible, so



that he may be able to plug the flue before the water gets out of the boiler. Tube-plugs and a rod for holding them are very requisite articles; but, in driving tube-plugs, care must be exercised not to hammer too hard, or a broken tube-sheet may result. Plugs are often at hand without a rod to hold them. In such an emergency a hard wooden rail can be used; the plug being fastened to the end by means of nails and wire, or even wet cord. Where no iron plug is available, a wooden plug driven well in, away from the reach of the fire, may prevent a burst tube from leaking, and enable the engine to go along; but wooden plugs are very unreliable for such a purpose. They may hold if the rupture in the tube should be some distance inside; but, should the cause of leaking be close to the tube-sheet, a wooden plug will burn out in a few minutes.

## CHAPTER XI.

### ACCIDENTS TO THE VALVE-MOTION.

#### RUNNING WORN-OUT ENGINES.

SOME of our most successful engineers, the men who pull our most important trains daily on time, attribute their good fortune in avoiding delays, to training they received in youth, while running or firing worn-out engines that could only be kept going by constant attention and labor. In such cases men must resort to innumerable makeshifts to get over the road; they have frequently to dissect the machinery to remedy defects; they learn in the impressive school of experience how a broken-down engine can best be taken home, and how breaking down can best be prevented. Firemen and young engineers generally feel aggrieved at being assigned to run on worn-out engines,—the scrap-heaps, as they are called: but the man who has not passed through this ordeal has missed a Golconda of experience; his potentialities are petrified without reaching action.

#### CARE AND ENERGY DEFY DEFEAT.

Among a certain class of seafaring men the captain of a ship who fails from any cause to bring his vessel

safely into port is regarded as disgraced; and, therefore, a true sailor will use superhuman efforts to prevent his ship from becoming derelict, often preferring to follow it to the bottom rather than abandon his trust. In many instances the sentiments and traditions of seamen teach railroadmen valuable lessons. The sacrifice of life is not desired or expected of engineers in their care of the vessel they command; but every engineer worthy of the name will spare no personal exertion, will shrink from no hardship, that will be necessary to prevent his charge from becoming derelict. Once I heard a hoary engineer, who had become gray on the footboard, make the proud boast, "My engine never was towed in." His calm words conveyed an eloquent sermon on care and perseverance. He had been in many hard straits, he had been in collisions, he had been ditched with engines, but had always managed to get them home without assistance.

#### WATCHING THE EXHAUST.

What the beating pulse is as an aid to the physician in diagnosing diseases, the sound of the exhaust is to the engineer as a means of enabling him to distinguish between perfective and defective working of the locomotive. The ability to detect a slight derangement by the sound of the exhaust, can only be acquired by practice in watching those steam-notes day after day, as they play their tune of labor through the smoke-stack. When the steam-ports are even, and the valves correctly set, with tight piston-packing, and valves free

from leaks, the notes of the exhaust will sound forth in regular succession in sharp, ringing, clear tones, every puff seeming to cut the steam clean off at the top of the stack. There is a long array of defects represented in the journey from this case of apparently perfect steam performance, to that where the exhaust-steam escapes as an unbroken roar mixed with uncertain, wheezy coughs.

THE ATTENTIVE EAR DETECTS DETERIORATION  
OF VALVES.

The deterioration of piston-packing, and the rounding of valve-seats, which produce an asthmatic exhaust, may be followed in their downward course if the engineer gets into the habit of listening to the exhaust, and marking its changes. It is very important that he should do so. The man whose ear from long practice has become sensitive to a false tone of the exhaust, needs not to make experiments, by applying steam to the engine while it stands in various positions, in order to find out where a blow comes from,—whether it is in the pistons or in the valves.

LOCATING THE FOUR EXHAUST SOUNDS.

Leaning out of the cab-window, he watches the crank as it revolves, and compares the noise made by the blowing steam with the crank position. When pulling on a heavy grade is an excellent time for noting imperfections in the working of valves and pistons; for the movements are comparatively slow, while the pressure of steam on the working-parts is so

heavy that any leak sounds prominently forth. The engineer observing perceives that the four sounds of the exhaust, due to each revolution of the drivers, occur a few inches before the crank reaches, first, the forward center, second, the bottom quarter, third, the back center, fourth, the top quarter. The first and third position exhausts emit the steam from the forward and back strokes of the right-hand piston: the second and fourth exhausts are due to discharges of the steam that has been propelling the left-hand piston. With these facts impressed upon his mind, he will understand, that if an intermittent blow occurs during the periods when the crank is traveling from the forward center to the bottom quarter, or from the back center to the top quarter, the chances will be that the right-hand piston needs to be examined. For the greatest pressure of steam follows the piston just after the beginning of each stroke, and that is the time a blow will assert itself. Should the blow occur while the right-hand crank is moving from the bottom quarter to the back center, or from the top quarter to the forward center, it will indicate that the left-hand piston is at fault. For at these periods the left-hand cylinder is receiving its greatest pressure of steam.

#### IDENTIFYING DEFECTS BY SOUND OF THE STEAM.

It is generally understood that an intermittent or recurring blow belongs to the pistons, and that a constant blow comes from the valves. But sometimes the valves blow intermittently, being tight at certain points of the travel, and leaky at other points. To

distinguish between the character of these blows is sometimes a little difficult except to the thoroughly practiced ear. The sound of the blow can be heard best when the fire-box door is open, and the novice should not fail to listen for it under that condition. The valve blow is a sort of wheeze, with the suggestion of a whistle in it: the piston makes a clean, honest blow, which would break into a distinct roar if enough steam could get through. But a whistling sound in the exhaust is, by no means, a certain indication of the valves blowing through; for sometimes the nozzles get clogged up with a gummy substance from the lubricating oils, and a distinct whistling exhaust results therefrom. With a watchful ear, the progress of degeneration in the valves can be noted day after day; for it is a decay which goes on by degrees,—the inevitable slow destruction that friction inflicts upon rubbing surfaces. Pistons are more erratic in their calls for attention. With them it is quite common for a stalwart blow to start out without any warning, the cause generally being broken packing-rings. The various kinds of steam packing seem more liable to have broken rings than the old-fashioned spring packing, but they generally run longer with less attention.

ACCIDENTS PREVENTED BY ATTENDING TO THE  
NOTE OF WARNING FROM THE EXHAUST.

The habit of closely watching the exhaust is likely to prove serviceable in more ways than in keeping the engineer posted on the condition of the steam-

distribution gear. Its sound often acts as a danger alarm, which should never go unheeded. Many an engine has gone home on one side, and not a few have been towed in cold, through accidents to the valve-gear, which could have been prevented had the engineer attended to the warning voice of a false exhaust. The nuts work off an eccentric-strap bolt; and it drops out, letting the strap open far enough to cause an uneven valve-travel. If the engineer hears this, and stops immediately to examine the machinery, he is likely to detect the defect before the strap breaks. Again, one side of a valve-yoke may have snapped, leaving the other side to bear the load; or bolts belonging to different parts of the links or eccentric-straps may be working out,—so that the uniformity of the valve-travel is affected; and the same result may be produced by the eccentrics getting loose. Young engineers, to whom these pages are addressed, should make up their minds that an engine never exhausts an irregular note without something being the matter which does not admit of running to a station before being examined. It may only be an eccentric slipped a little way, a mishap that is not calculated to result disastrously; but, on the other hand, it is probably something of a more dangerous character.

#### NEGLECTING A WARNING.

Engineer Joy of the D. & E. road went in with a broken eccentric-strap. Questioning him about the accident brought out the fact that, in starting from a

station, he heard the engine make two or three curious exhausts; but he was running on a time-order, and did not wish to cause delay by stopping to examine the engine. But he had not gone half a mile when he found it necessary to stop and disconnect the engine, and by doing so held an express train forty minutes.

HOW AN ECCENTRIC-STRAP PUNCHED A HOLE  
IN A FIRE-BOX.

A representative case of neglecting a plain warning happened on an Illinois road some time ago. John Thomas was pulling a freight train up a grade, when, to use his own words, "The engine began to exhaust in the funniest way you ever heard. She would get on to three legs for an engine length or so, then she would work as square and true as she ever did, but only for a few turns, when she got to limping again." This runner knew that something was wrong, and he determined to examine the engine at the next stopping-point. But delays in such a case are full of peril. When he got over the grade and shut off steam, there was a tumultuous rattling of the reverse-lever, succeeded by a fearful pounding about the machinery; a tearing up of road-bed sent a shower of sand and gravel over the train; then a scream from escaping steam and water drowned all other noises, and the engine was enveloped in a cloud of blinding vapor. The forward bolt of one of the eccentric-strap rods had worked out and allowed the end of the rod to drop on the track. Then it doubled up and



tore away the whole side of the motion; and part of a broken eccentric-strap knocked a hole in the fire-box. Here was the progress towards destruction: A small pin got lost, which permitted the nut of an important bolt to unscrew itself; then this bolt, with many a warning jar and jerk, escaped from its place in the link; and the conditions for a first-class breakdown had come round.

#### INTEREST IN THE VALVE-MOTION AMONG ENGINEERS.

Whenever locomotive engineers congregate in the round-house, in the lodge or division-room, a fruitful theme of conversation and discussion is the valve-motion. Curious opinions are often heard expressed upon this complex subject. There are comparatively few men who understand it properly: but it has a fascination which attracts all alike, the wise and the ignorant; and the man who is altogether uncertain about the true meaning of lap and lead, expansion and compression, is generally more loquacious on valve-motion than the engineer who has made the subject an industrious study.

#### TROUBLE WITH THE VALVE-MOTION.

However well each may understand his business, in one respect all engineers are in perfect harmony; that is, in hating to encounter trouble with the valve-gear on the road. The valves being the lungs of the machine, any injury or defect to their connections strikes at a vital organ. With a good valve-motion,

and valves properly set, the steam is distributed so that nearly an equal amount is admitted through each port in regular rotation; the release taking place in even succession. This makes the exhaust-notes uniform in pitch and period. A sudden departure from this uniformity indicates that something is wrong with the valve-motion. It should be the signal to stop and institute a searching examination. In doing so, avoid jumping at conclusions regarding the cause of the irregularity, and coolly examine, separately, each part whose motion influences the valve-travel.

#### A WRONG CONCLUSION.

Fred Bemis missed his luck by jumping too readily at conclusions. Something happened to his engine; and he stopped by compulsion, and found it would not move either way. He felt certain that both eccentrics on one side had slipped; and, considering himself equal to setting any number of eccentrics, he got down and fixed them in what he supposed was the proper position. But, on trying to move the engine, he found it still refused to go. He kept working at those eccentrics without result till his water got low, and he was compelled to dump the fire; the consequence being that the engine went cold, and was towed home. When an examination was made, it was found that a broken valve-yoke was the cause of trouble.

## LOCATING DEFECTS OF THE VALVE-MOTION.

When anything goes wrong with the valve-motion, the first point of investigation is, to find out which side is at fault. This can be ascertained by opening the cylinder-cocks, and giving the engine steam. With the reverse-lever in forward motion, the forward cylinder-cocks should show steam when the crank-pins are traveling below the axle, and the back cocks should blow when the pins make their similar revolution above the axle. Any departure from this method of steam-distribution will make one side work against the other. When the engineer has satisfied himself on which side the defect lies, he will do well to thoroughly examine the eccentrics with their straps and rods, the links with their hangers and saddles, the rocker-box and -arms with all the bolts and pins connecting these articles. What might be regarded as a trifling defect, sometimes makes an engine lame. I have known a loose valve-stem key put an engine badly out of square. Eccentric-rods, slipping, often produce this effect. When the eccentrics are found in the proper position, the rocker-box secure in the shaft, and all the bolts, pins, and keys in good order, and in their proper positions, the fault may be looked for in the steam-chest.

## POSITION OF ECCENTRICS.

With engines where keys are not used to secure the eccentrics to the shaft, their slipping on the road is a common occurrence. Eccentric-strap oil-passages

getting stopped up, or neglect in not oiling these straps or the valves, puts an unnecessary tension on the eccentrics, which often results in their slipping on the shaft. Engineers ought to mark the proper position for eccentrics on the shaft; so that, when slipping happens, it can be adjusted without the delay that often occurs in calculating the right position. When the crank-pin is on the forward center, the body of the go-ahead eccentric is above the axle, and the body of the back-up eccentric is below the axle, each of the eccentrics being advanced about  $\frac{1}{8}$  of the revolution from the right angle position towards the crank-pin; or, to state it more accurately, the center of the eccentric is advanced a horizontal distance to equal the lap and lead of the valve. If the valve had neither lap nor lead, the eccentrics would stand exactly at right angles to the crank. As it is, both of them have a tendency to hug the crank; the eccentric which regulates the distribution of steam following the crank. Every engineer should familiarize himself with the correct position of eccentrics, so that, when trouble happens with the valve-gear on the road, he will experience no difficulty in grappling with the mishap.

#### METHOD OF SETTING SLIPPED ECCENTRICS.

The slipping of one eccentric is a trifling matter, which can be quickly remedied if the set-screws are in a position where they can be reached conveniently. If it is a go-ahead eccentric, set the engine on the center of the disabled side,—no matter which center,

—put the reverse-lever in the back notch of the quadrant, and scratch a line with a knife on the valve-stem close to the gland. Then put the lever in the forward notch, and move the slipped eccentric till the line appears in the point where it was made. Fasten the set-screws, and the engine will be found true enough to proceed with the train. Care must be taken in moving the eccentric to see that the full part is not placed in the same position as the other one, or they will both be set for back motion. A back-up eccentric slipped, while the go-ahead one remains intact, can be adjusted in a similar way; the scratch on the valve-stem being made with the engine in full forward motion, and the adjustment of the eccentric done in full back motion. The philosophy of this method is, that the valve is in nearly the same position at the beginning of the stroke for the forward or back motion; and the position of the eccentric which has not moved is used to find the proper place for the one which slipped.

Should the unusual circumstance of both eccentrics on one side slipping overtake an engineer, he will have to pursue a different method of adjustment. The most systematic plan is to place the engine on the forward center, and set the go-ahead eccentric above the axle, and the back-up eccentric below the axle. With the reverse-lever in the forward notch, advance the top eccentric till the front cylinder-cock shows steam, which can be ascertained by blocking the wheels, and slightly opening the throttle. That will put the go-ahead eccentric near enough to the proper position for

running. For the back-up eccentric, pull the reverse-lever into back-motion, and turn the eccentric towards the crank-pin till steam appears at the front cylinder-cock; and that part of the motion will be right. Or the back-up eccentric can be set by the forward eccentric in the manner described where one eccentric has slipped.

#### SLIPPED ECCENTRIC-RODS.

Where slotted rods are used, they frequently slip, making the engine lame. The cause of trouble in such a case can be identified by moving the engine slowly, with the cylinder-cocks open. The disturbance to the regularity of the valve's motion caused by a slipped rod will admit steam prematurely on one end of the cylinder, while it delays the admission on the other end. The valve is made to travel more on one side of the exhaust center than on the other. Lengthening or shortening the valve-stem has a similar effect, but this makes the engine lame in both gears; while the slipping of an eccentric-rod only makes the engine lame in the motion that the rod belongs to. This is subject to a slight modification, however; for the back-motion eccentric being badly out of square, will affect the correctness of the forward motion, when the engine is working close hooked up. But in full motion it will not be perceptible.

#### DETECTING THE CAUSE OF A LAME EXHAUST.

If in moving the engine ahead slowly, with the cylinder-cocks open, it is found that steam is admitted

to the cylinder before the piston has nearly reached the center or dead point, or that the back cylinder-cock does not show steam till after the piston has passed the back center, the eccentric-rod is too long. The rod being too short produces precisely an opposite effect. The steam arrives late on the back stroke, and ahead of time on the forward stroke. This is different from the action of the steam where an eccentric has slipped. In that case, there will be pre-admission of steam before the beginning of both strokes, or post-admission, that is, late arrival of steam, for both strokes. Take a go-ahead eccentric for example. If it slips backward on the shaft, its effect will be to delay the admission of steam till after the beginning of each stroke; and, if it slips forward, the result will be to accelerate the lead of the valve opening the steam-port before the piston has reached the commencement of each stroke.

#### WHAT TO DO WHEN ECCENTRICS, STRAPS, OR RODS BREAK.

When either of these accidents happens, the safest plan is to take down both straps and rods on the defective side. Some engineers leave the back-up eccentric strap and rod on, when the forward strap or rod has broken; but it is a little risky under certain conditions. After getting the eccentric straps and rods down, drop the link-hanger away from the tumbling-shaft, disconnect the valve-stem, and tie the valve-rod to the hand-rail. Then set the valve in the middle of the seat, so that it will cover both the steam-ports,

and hold it in that position by pinching the stem with the gland, which is done by screwing up the gland obliquely. Take down the main rod, and block the cross-head securely at the back end of the guides. Good hard-wood blocking prepared beforehand should be used for this purpose, and it ought to be fastened with a rope or marline. A neater plan for holding the cross-head in place is described by Frank C. Smith, in the *Torch*. He says, "Have the blacksmith make a hook out of a piece of inch and a half round iron; also a piece about fifteen inches long by one and a half thick, and four inches wide, with a hole through the centre for the shank of the hook to pass through. This shank is threaded for a nut. Now, when it is necessary to block a piston, get it to the back end, pass the hook around the wrist of the cross-head, and the other end through the straight piece which bears against the yoke supporting the back end of the guides; run up a nut on the shank of the hook, hard against the cross-piece, and the piston is secured." The piston being properly fastened, it is a wise supplement to the work to tie the cylinder-cocks open, or to take them out altogether. The engine is now ready to proceed on one side.

Young engineers can not be too strongly impressed with the necessity for having the cross-head properly secured before trying to move the engine. I have repeatedly known of serious damage being caused by placing too much confidence in weak blocking. Taking out the cylinder-cocks is a wise security against accidents of this kind; for, should a little steam be



passing through the valve, it has a port of escape without putting heavy pressure on the piston.

#### DIFFERENT WAYS OF SECURING THE CROSS-HEAD.

In regard to the method of securing the piston when one side of an engine is taken down, there is considerable diversity of opinion among engineers. Some men maintain that the proper and quick plan is, merely to move the piston to one end of the cylinder, pushing the valve in the same direction, so that the steam-port will be open at the end away from the piston. This will keep the cylinder full of steam, and hold the piston from moving. But, if by any accident the valve should be moved to the opposite end of the seat, steam would get to the wrong end of the cylinder, and the piston would certainly smash out the head. Another risky plan, practiced by men economical of work, is to place the valve on the center of the seat, and let the piston go without fastening. These slipshod methods do not pay.

When it is decided to push the piston to the back end of the cylinder it should not be pushed far enough to permit the packing-rings to drop into the counter-bore. It should not be forced back of its ordinary travel. This can be identified by the travel of the cross-head on the guides. A small block that will cover the extent of the counter-bore should be inserted between the cross-head and the back of the guides.

BROKEN TUMBLING-SHAFT.

This accident is very serious; but it need not disable the engine, although it will lessen the engineer's power to manage it freely. To get the engine going, calculate the position the links must stand in to pull the train, and cut pieces of wood to fit between the block and the top and bottom of the links, so that the latter may be kept in the required position. For forward motion, there will be short pieces in the top, and long pieces in the bottom. When back motion is needed, reverse the pieces of wood. A common plan is to use one piece of wood, working the engine in full gear.

The same treatment will keep an engine going when the tumbling-shaft arms, the reach-rod, the link-hanger, or the saddle-pin breaks. The failure of a link-hanger or saddle-pin will only necessitate the blocking of one side.

BROKEN VALVE-STEM, OR VALVE-YOKE.

For a valve-stem broken, the eccentric-strap or link need not be interfered with. If the break is outside the steam-chest, take down the valve-stem rod, and set the valve on the middle of the seat; take down the main rod, and secure the piston as previously directed. With a valve-stem broken inside the chest, or a valve-yoke broken, a little additional work is necessary. The steam-chest cover must now come up, and the valve be secured in its proper place by pieces of wood, or any other material that will keep it from moving; and the stuffing-box must be closed, to

prevent escape of steam through the space vacated by the valve-stem.

#### TO SECURE A BROKEN VALVE-STEM.

When metallic packing is used in valve-stem, the best way to hold it from moving when that side is disconnected is to remove the oil-cup and screw in a set-screw that will pinch the stem and hold it tight. A better way is to carry a bracket that will fit the gland-studs at one end and the keyhole at the other, and use that to prevent the valve-stem from moving.

#### WHEN A ROCKER-SHAFT OR LOWER ROCKER-ARM BREAKS.

A broken rocker-shaft, or the fracture of the lower arm, entails the taking down of both eccentrics and the link, besides the main rod, and the securing of the valves and piston. The breaking of an upper rocker-arm is equivalent to a broken valve-stem, and requires the same treatment.

#### MISCELLANEOUS ACCIDENTS TO VALVE-MOTION.

Accidents to the valve-seat, such as the breaking of a bridge, can be fixed for running the engine home on one side, by covering the ports, and stripping that side of the engine, just as had to be done for a broken valve-yoke. If a serious break in a bridge occurs, it is indicated by a tremendous blow through the exhaust port, out by the stack. A mishap of much less consequence than a broken bridge is a "cocked" valve, and the small mishap is very liable to be mistaken for the greater one. Where the yoke is tight-

fitted, or out of true with the line of the stem, some engines have a trick of raising the valve away from the seat, and holding it there. This generally happens going into a station; and, when steam is applied in starting out, an empty roar sounds through the stack. Moving the valve with the reverse-lever by quick jerks will generally reseat a cocked valve, but sometimes it gets stuck so fast that it has to be hammered out of the yoke.

When a locomotive shows the symptoms which indicate a broken valve, a broken bridge, or a cocked valve, the engineer should exhaust every means of testing the matter from the outside before he begins an interior inspection by raising the steam-chest cover. If jerking the valve with the reverse-lever, or moving the engine a little, will not stop the blow, he should disconnect the valve-stem, and shake the valve by that means.

When a valve breaks, disabling its side of the engine so badly that it cannot be used, the valve should be taken out, and a piece of strong pine-plank secured over the ports.

#### BROKEN STEAM-CHEST COVER.

A very serious and troublesome accident, which may come under the head of steam-distribution gear, is the breaking of a steam-chest or of a steam-chest cover. It takes skillful management to get an engine along when this has happened. The most effectual way to restrain loss of steam when a chest or cover has broken, is to slack up the steam-pipe, and slip a piece of iron plate, lined with sheet-rubber, leather, canvas, or any other

substance that will help to make a steam-tight joint, into the lower joint of the steam-pipe. If this is properly done, it ends the trouble, when the joints are tightened up. But the difficulties in the way of loosening steam-pipe joints in a hot smoke-box are often insurmountable, especially when the nuts and bolts are solid from corrosion, which is generally the case where they have not been touched for months. In such a case it is better to resort to the more clumsy contrivance of fitting pieces of wood into the openings to the steam-passage, and bracing them in place by means of the steam-chest bolts. A man of any ingenuity can generally, by this means, save himself the humiliation of being towed home, and yet avoid spending much time over the operation. When the engineer has succeeded in securing means for preventing the escape of steam, the main rod must be taken down, and the valve-stem rod disconnected from the rocker-arm. In this instance the piston needs no further attention, after the main rod has been disconnected; for there will be no ingress of steam to the cylinder to endanger its safety.

#### STEAM-PIPE BURST.

The breaking of a steam-pipe in the smoke-box is even a more harassing mishap than a burst steam-chest or cover. The only remedy for this is the fastening of an iron plate to the top joint of the steam-pipe, thereby closing up the opening. A heavy plug of hard wood may be driven into the opening, and braced there for a short run; but such a stopper is

hard to keep in place, owing to the shrinkage caused by the intense heat of the smoke-box.

#### TESTING THE VALVES.

An experienced engineer will most easily determine the existence of leaks between the valves and their seats when the engine is working, and the indications of that weakness have already be noticed. But it sometimes happens that a man wishes to test the condition of the valves when the engine is at rest. This can be most readily accomplished by placing the engine so that the rocker-arm stands in the vertical position. Open the smoke-box door so that the exhaust nozzles can be seen. Now block the wheels, and give the engine steam. If the valve blows, the steam will be seen issuing from the nozzle on the side under examination. As the tendency of a slide-valve is to wear the seat concave, it sometimes happens that a valve is tight on the centre, yet leaky in other positions. Moving the valve with the reverse-lever as far as can be done without opening the steam-port, will sometimes demonstrate this. The cranks should be placed on the eighths positions when the valves are being tested.

#### TO IDENTIFY BLOW FROM BALANCING-STRIPS.

When balancing-strips on top of valve leak, the easiest way to find out which side is at fault is to place the valve in the middle of the seat aud open the throttle lightly. That position puts the hole in the valve over the exhaust port and the escaping steam has an open road to the atmosphere.

## CHAPTER XII.

### ACCIDENTS TO CYLINDERS AND STEAM CONNECTIONS.

#### IMPORTANCE OF THE PISTON IN THE TRAIN OF MECHANISM.

THE piston is an autocratic member of the machine. For thousands of miles it toils to push the engine ahead, everything going smoothly so long as it is confined to its recurring journey; but let any attachment break, or a key fly out that will increase the piston's travel, and away the piston goes, right through a cylinder-head.

#### CAUSES THAT LEAD TO BROKEN CYLINDER-HEADS.

The causes which most commonly lead the piston to smash out cylinder-heads, are broken cross-heads, broken piston-rods, and broken main-rods. A main crank-pin or wrist-pin breaking, is almost certain to leave one end of the cylinder a wreck. These may be termed the major causes for breaking out cylinder-heads; but there are numerous minor causes, which are scarcely less destructive. A piston-rod key begins to work loose. It is hammered down occasion-

ally, which does not improve its fit; and some day it jumps out altogether, letting the piston go on a voyage of discovery. A machinist of the careless sort has been examining a piston's packing, and, in screwing up the follower-bolts, one of them gets a twist too much. Drilling out a follower-bolt is a troublesome operation, so Mr. Careless lets it go. On the road this head drops out, and a broken cylinder-head is the consequence. One of the worst causes of breakage to a cylinder that I have ever seen, was caused by the packing-ring of the piston catching in the steam-passage. Part of the ring broke off, and wedged itself between the advancing piston and the cylinder. The wedge split the cylinder open, and the remainder of the piston acted like a pulverizer upon the fragment of the cylinder.

#### BROKEN CYLINDER-HEADS OFTEN PREVENTABLE.

The causes which eventually lead to broken cylinder-heads often originate from preventable strains. Thus, cross-heads are frequently fractured by main-rod connections pounding; and weaknesses, that ultimately bring crank-pins to disaster, originate in a similar way. A loose piston-key is liable to crack the piston-rod, if it does not give trouble by jumping out. Loose guides have a tendency to spring piston-rods, and throw unnecessary strain upon them. Pistons lined out of true are dangerous for the same reason. And so the list of potential accidents grows. Like the steady water-drop that wears into the adamant rock, tri-



fling defects, assisted by time's action, prove stronger than the most massive machine.

When anything happens to permit the piston to break out a cylinder-head the engine can be put in running trim by taking off the valve-rod and the main-rod, and setting the valve on the center of the valve-seat. Blocking the cross-head is unnecessary, if the break will allow the escaping steam to pass through; for then no further tension can be put upon the piston to cause further damage. If, by an extraordinary freak of good luck, a piston-rod breaks without causing other damage, the cylinder-head must be taken off, and the piston removed. Then cover the ports, and take down the main-rod on that side. Or, if the cross-head is all right, the main-rod may be left untouched. When the cross-head breaks, it generally entails taking out the piston, centering the valve, and taking down the main-rod on that side.

#### WHEN A MAIN-ROD BREAKS.

With a broken main-rod which does not knock out the cylinder-head, the main-rod and valve-rod should be taken down, the valve secured on the center of the seat, and the cross-head blocked with the piston at the back end of the cylinder.

#### CRANK-PIN BROKEN.

For a broken main crank-pin, the above method of stripping the engine will do with the addition of taking down both side-rods. An accident which disables one side-rod, requires that the other one shall be taken

down also, or there will be trouble when the engine is attempted to be run with one side-rod. The rod might go all right so long as no slipping happened. But, if the engine began to slip while passing over the center, the side-rod would have no leverage on the back-crank to slip its wheel; and a broken rod or crank-pin would almost certainly ensue.

#### BROKEN SIDE-ROD.

A broken side-rod, that is not accompanied by other damage, requires both side-rods to be taken down. All the inconvenience arising from this is, that the engine is more liable to slip. But, with dry rails, the ordinary eight-wheel engine can get along very well without its side-rods.

With six- or eight-wheel connected engines different treatment is necessary. In case the back section of a side-rod of a six- or eight-wheel connected locomotive should break it would be necessary to take down the same section on the other side. If the front side-rod of a six connected or consolidation engine broke, it would be all right to take down the same section on the other side. In case the middle section side-rod of a consolidation engine it is generally necessary to take down all the side-rods.

#### THROTTLE DISCONNECTED.

Any accident to the throttle-valve or its attachments, which deprives the engineer of power to shut off steam, is very dangerous, and calls for prompt action. Lose no time in reducing the head of steam to fifty or sixty

pounds, or to the pressure where the engine can easily be managed with the reverse-lever.

With the aid of a power-brake, an engineer can get along fairly with a light train, after an accident has happened which prevents the closing of the steam from the cylinders; but constant vigilance and thoughtful labor are needed.

#### WHAT CAUSES A DISCONNECTED THROTTLE.

The most common causes of trouble with the throttle are the breaking or working out of one of the bolts that operate the valve within the dome, the breaking of a valve-rod, or working off of nuts that should secure the connection. Where the throttle fails with the valve closed, and the engineer finds it necessary to take the dome-cover off to prevent his engine from being hauled in, he will generally find the trouble to lie with the connections mentioned, or with the bolts belonging to the bell-crank, that is located near the bottom of the stand-pipe. Sometimes the nuts on the top of the throttle-valve stem work off: but, in such a case, there is no difficulty in opening the valve; it is when the engineer wants to close it, that the discomfiture comes in. Some steam-pipes are provided with a release-valve near the throttle, to relieve the pipe from intense back-pressure when the engine is reversed. The sudden reversing of an engine sometimes jerks this valve out of its seat, leaving an open passage between the boiler and steam-chest. This acts like a mild case of unshipped throttle, and must be controlled in a similar way.

## BURSTING A DRY PIPE.

The bursting of a dry pipe is similar in effect to the action of a throttle becoming disconnected while open; and it may ever prove harder to control, according to the size of the opening. Engineer Halliday had a trying time with a case of this kind. While swinging along the E., F. & G. road, with a heavy train of freight, a herd of horses ran in from an open crossing-gate, and started up the track just in front of the engine. As there was a bridge a short distance ahead, Halliday reversed the engine in his anxiety to prevent an accident. The train stopped for an instant, when the engine began to push it back. Halliday tried to throw the lever to the center, but never before had he felt such a pressure acting upon it. Again and again he tried to throw the lever over; but every time it proved too formidable a struggle, and the catch found its way into the full-back notch. Meanwhile the train was gaining speed in the wrong direction, and a passenger train was not many miles behind. Beginning to realize the true state of affairs, Halliday called for brakes, opened the fire-box door, closed the dampers, and started the injector. Then he directed the fireman to throw some bucketfuls of water upon the fire, while he tied down the whistle-lever, letting the steam blow. The promptest means for reducing the pressure of steam were now in operation, and his next move was to try the reverse-lever again. Both men grasped the lever and, by a combined effort, forced it past the center; and Samson's hair was cut. It was afterwards found

that a long rent had opened in the dry pipe, letting the full boiler-pressure upon the valves, which moved hard through being dry; the hot gases pumped through them in reverse motion, having licked off every trace of lubricating unguent.

#### OTHER THROTTLE ACCIDENTS.

Cases of serious trouble resulting from accidents to throttle-connections would be easy to multiply. Two incidents with similar originating conditions, but with very different results, will suffice. Engineer Phelps was pulling a full train of coal over rails that were neither wet nor dry, and had just enough frost upon them to be wicked. He was having a bad time slipping, but was working patiently along, when the throttle became disconnected with the valve open. The engine at once started on a whirl of slipping that threatened disaster, but it was immediately controlled by the engineer pulling the reverse-lever to the center notch. Engineer Cook of the F., G., & H. road, was not so fortunate when the stem of his throttle-valve broke on a slippery day. As the wheels began spinning round, Cook lost his head, and kept working at the throttle-lever to try to stop. Seeing this was of no avail, he grasped the sand-lever, and tugged vigorously at the valves. A season of tumult succeeded; and, when the engine stopped presently, it was found to be a deplorable wreck. It was hard to tell, from the look of the ruin, what part of the locomotive broke first; but the crank-pins on one side were cleaned off, and the piston was out through the cylinder-head. The side-rod on the

other side broke close to the strap, and was twisted up like a spiral spring.

#### POUNDING OF THE WORKING-PARTS.

It is good for an ambitious young engineer, who desires to thoroughly master his calling, to walk occasionally into the room where a well-managed automatic cut-off engine is at work, and watch its smooth, noiseless movements. There he may find an ideal of how an engine should run. The nature of the work performed by a locomotive engine prevents it from being operated noiselessly, and the smoothness of its action must always compare unfavorably with a well-constructed stationary engine; but the connections which transmit the power of a locomotive should be free from knock or jar, if they are properly proportioned, and skillfully put together.

#### SOME CAUSES OF POUNDING.

To an engineer with a well-regulated mind, a pound about the engine is a source of continual irritation. If a pound arises from a cause which can be remedied by an engineer, the careful man will soon perform the necessary work to end the noise. Sometimes the origin of a pound is hard to discover: very often it is beyond the power of the engineer to stop it. Some makes of locomotives always pound when working in full gear. With such an engine, a nervous engineer will fuss, pushing up wedges until they stick fast, and cause no end of grief to get them down again. He will key up the main-rod connections till they run hot,

and he will prophesy that the engine is going to pieces. But the engine hangs together all the same, and is only suffering from want of lead, or want of compression. Where an engine is deficient in the cushioning to the piston, due to compression or lead, the momentum of the piston and connecting-rod is suddenly checked at the end of each stroke. The concussion to these working-parts is so great that pounding will be produced. As the engine gets hooked towards the center, this pounding will cease, because compression and the lead opening increase as the motion is notched back. The most common causes for pounding with locomotives are worn main-rod connections, and driving-boxes too loose in the jaws, or the brasses loose in the driving-boxes. If side-rods are out of tram, or have the brasses badly worn, they sometimes pound when passing the centers. A cross-head will pound when the guides are worn very open. This last defect is liable to cause a bent piston-rod. A piston makes a tremendous pound when a badly connected rod allows it to touch a cylinder-head, and a very ominous pound is produced when the spider gets loose on the piston-rod, and a piston-rod loose in the cross-head will make itself heard all over the engine.

#### LOCATING A MYSTERIOUS POUND.

Several years ago a very troublesome and mysterious pound caused the writer a great deal of annoyance. He was running an old engine, with cylinders that had been bored out until no counter-bore was left. The piston had worn a seat leaving a small ridge at the end

of its back travel. The main rod was taken down one day; and, in putting it up again, the travel of the piston was slightly altered. The engine started out with a pound, and kept it up. If any of my readers have been working an engine that seemed to hang together merely by luck, away on construction work on the wild prairies, with no machine-shops in the rear to appeal to for aid or counsel, with all his own repairing to do without tools or skilled assistance, they will understand the difficulty experienced in locating that pound at the back end of the cylinder.

A cylinder loose on the frame, or a broken frame, will jar the whole machine; and both of these defects are serious, and demand increased care in taking the engine along with the train. Loose driving-box brasses produce a pound which is sometimes difficult to locate. In searching for the cause of a pound, it is a good plan to place the engine with one of the cranks on the quarter, block the wheels, and have the fireman open the throttle a little, and reverse the engine with the steam on. By closely watching in turn each connection, as the steam through the piston gives a pull or a thrust to the cross-head, the defect which causes the pound may be located. Never run with a serious pound inside of a cylinder. It is an almost certain indication that a smash is imminent.



## CHAPTER XIV.

### OFF THE TRACK.—ACCIDENTS TO RUNNING-GEAR.

#### GETTING DITCHED.

THERE is something pathetic in the spectacle of a noble locomotive, whose speed capabilities are so wonderful, lying with its wheels in the air, or sunk to the hubs in mud or gravel. Kindred sights are, a ship thrown high and dry upon the beach, away from the element that gives it power and beauty; or a monster whale, the leviathan of the deep, lying stranded and helpless upon the shore.

Few engineers have run many years without getting their engine off the track in some way,—over the ends of switches, by jumping bad track, or getting into the ditch through some serious accident, collision or otherwise. Most of them have felt that shock of the engine thumping over the ties, and momentarily wondered in what position it was going to stop; doing all in their power, meanwhile, to stop, and prevent damage.

#### DEALING WITH SUDDEN EMERGENCIES.

Of course, an engineer's first duty is to conduct his engine in a way that will avoid accident so far as

human foresight can aid in doing so; but, when an accident is inevitable, his next duty is to use every exertion towards reducing its severity. The most common form of serious accident occurring on our railroads is a collision. Rear-end collisions occur most frequently, although head-to-head collisions annually claim many victims. When an accident of this kind is impending, the engineer generally has but a few seconds of warning; but these brief seconds well utilized often save many lives, and impress the principal actor with the stamp of true heroism. Rounding a curve at a high speed, an engineer perceives another train approaching. Quick as thought he shuts off steam, applies the brake, and opens the sand-valves. This will take about ten seconds' time; and, if the engine is running thirty miles an hour, the train will pass over forty-four feet each second. Assuming that no reduction of speed has taken place till all the appliances for stopping are in operation, four hundred and forty feet will be passed over as a preliminary to stopping. With the automatic Westinghouse brake, application and retarding power are almost simultaneous. To reverse the engine when driver-brakes are in use is to cause sliding of wheels without helping to stop the train quickly. Until he has applied all means of reducing speed, an engineer rarely or never consults his own safety, however certain death may be staring him in the face. But after the brakes are known to be doing their work, aided by sanded rails, personal safety is considered. A glance at the position of the two trains tells if they are coming violently together; and the

engineer jumps off, or remains on the engine, as he deems best. This applies to trains equipped with continuous brakes.

#### STOPPING A FREIGHT TRAIN IN CASE OF DANGER.

With freight trains where the means of stopping are not immediately under the hand of the engineer, he must call for brakes on the first indication of danger, and do all that a reversed engine can achieve to aid in stopping the train. Where a driver-brake is used, the engineer will have to watch the reversed engine; because the wheels will soon begin sliding, even on thick sand, and their retarding power will be seriously diminished. To prevent this, the engineer should let off the driver-brake, and open the cylinder-cocks, till the wheels begin to revolve, when the brake may be applied again. Working and watching in this way greatly assist in stopping a train, and preventing the flattening of wheels.

#### SAVING THE HEATING-SURFACES.

Should the engine get into the ditch, the engineer's first duty is to save the engine from getting burned, unless saving of life, or protecting the train, demands his attention. If the engine is in a position where the flues or fire-box crown will be left without water, the fire should be quenched as quickly as possible. Sand or gravel thrown over the fire, and then saturated with water, is a good and prompt way of extinguishing the fire.

## GETTING THE ENGINE ON THE TRACK.

It can be understood in a few minutes after derailment whether or not the engine can be put back on the track without assistance. Sometimes a pull from another engine is all that is required: again, nothing can be done without the aid of heavy tools to raise it up. In this case, no time should be lost in sending for the wrecking outfit. It often happens that an engine gets off the track while switching among sidings, and sinks down in the road-bed so as to be helpless. In an event of this kind, jacking up a few inches will often enable the engine to work back to the rails. Before beginning to hoist with the screw-jacks, some labor can generally be saved by putting pieces of iron between the bottom of the driving-boxes and the pedestal-braces. As the wheels begin to rise out of the gravel, pieces of plank or wooden wedges should be driven under them to hold good every inch raised. Where the attempt is made to work an engine on the rails by means of wrecking-frogs, wooden filling should be laid down crosswise to prevent the wheels from sinking between the ties, should they slip off the frogs. Where jacking up has to be resorted to, there is often difficulty experienced in getting up the engine-truck; as raising the frame usually leaves the truck behind in the mire. The best plan is to jack up the front of the engine to the desired level, then with a rail well manned pry up the truck, and hold it in position by driving shims under the wheels. An engine

will generally go on the rails easiest the way it comes off.

When a derailed engine is being pulled on the track by another engine, the work should be done carefully, and with proper deliberation. When everything is made ready for a pull, some men act as if the best plan was to start both engines off with full throttle; and this often leaves the situation worse than it was at first. When truck-wheels stand at an angle to the track, it is often necessary to jerk them in line by attaching a chain or rope to one side. A wrecking-frog should be laid in front of the wheel outside the rail, and blocking before the inside wheel, sufficient to raise the tread of the wheel above the level of the rail. Then move ahead slowly, and the chances are that the wheels will go on the rails. Sometimes the easiest way is to open the track at a joint, move it aside to the line of the wheels, and spike it there, then draw or run the engine on.

Having an engine off the track is a position where good judgment is more potent than a volume of written directions.

#### UNDERSTANDING THE RUNNING-GEAR.

The driving-wheels, axles, boxes, frames, with the trucks and all their attachments, are somewhat dirty articles to handle. The examination of how they are put together, and how they are hanging together, is pursued under soiling circumstances. Perhaps this is the reason these things are studied less than they ought to be. To creep under a greasy locomotive to

examine wheels, axles, and truck-boxes is not a dignified proceeding by any means; but it is a very useful one. The running-gear is the fundamental part of the machine, and its whole make-up should be thoroughly understood. The builds of trucks are so multifarious that no specified directions can be given respecting accidents happening to them. There is, therefore, the greater need for an engineer's familiarizing himself with the make-up of his running-gear, so that when an accident happens he will know exactly what to do. Disraeli said: "There is nothing so likely to happen as the unexpected." This applies very aptly to railroad engineering. Industrious accumulation of knowledge respecting every part of the machine is the proper way to defy the unexpected.

#### BROKEN DRIVING-SPRING.

The running-gear of some engines is so arranged that, in case a driving-spring breaks on the road, it can readily be replaced if a spare spring is carried. With the average run of engines, however, and the accumulating complication of brake-gear attached to the frames, the replacing of a driving-spring is a tedious operation, that would involve too much delay with an engine attached to a train. Consequently engineers seldom attempt to change a broken spring. They merely remove the attachments likely to shake out of place, and block the engine up so as to get home safely. When a forward driving-spring breaks, it is generally best to take the spring out with its saddle and hangers. Then run the back drivers up on wedges

to take the weight off the forward drivers, and put a piece of hard wood or a rubber spring between the top of the box and the frame. Now run the forward drivers on the wedges, which will take the weight off the back drivers, and with a pinch-bar pry up the end of the equalizer till that lever stands level, and block it in that position by jamming a piece of wood between it and the frame. For a back driving-spring, this order of procedure should be reversed. A back driving-spring is often hard to get out of its position; and it sometimes can be left in place, as it is not very liable to cause mischief.

Where a spring drops its load through a hanger breaking, the mishap can occasionally be remedied by chaining the spring to the frame. Should this prove impracticable, the same process must be followed as that which was made necessary by a broken spring.

#### EQUALIZER BROKEN.

For a broken equalizer, all the pieces likely to shake off, or to be caught by the revolving wheels, must come out; and both driving-boxes on that side must be blocked on top with wood or rubber. Where good screw-jacks are carried, it will often prove time-saving to raise the engine by jacking up at the back end of the frame instead of running it up on wedges. Where the wedge plan is likely to prove easiest, it must be adopted only on a straight track; and then too much care cannot be used to prevent the wheels from leaving the rails.

## ACCIDENTS TO TRUCKS.

The breaking of an engine-truck spring which transmits the weight to the boxes by means of an equalizer, requires that the equalizer should be taken out, and the frame blocked above the boxes. This blocking above the boxes is necessary to prevent the two unyielding iron surfaces, which would otherwise come together, from hammering each other to pieces. Wood or rubber has more elasticity, and acts as a spring. Whatever may be the form of truck used, if the breaking of a spring allows the rigid frame to drop upon the top of one or more boxes, it must be raised, and a yielding substance inserted, if the engine is to be run even at a moderate speed, and the engineer wishes to avoid further breakage. Sometimes truck-springs, especially with tanks, are so arranged that the removal of one will take away the support of the frame at that point. In such a case, a cross-tie or other suitable piece of wood must be fitted into the place to support the weight which the spring held up.

## BROKEN PONY-TRUCK CENTER PIN.

When the center pin of a pony-truck breaks the best remedy is to put in a new one. If that is not at hand, jack up the front of the engine and block down the cross equalizer at back of long equalizer enough to prevent forward end from striking pony-axle.



## BROKEN FRAME.

A broken truck-frame can generally be held together by means of a chain, and a piece of broken rail or wooden beam to act as a "splice." Should a truck-wheel or axle break, it can be chained up to enable the engine to reach the nearest side track where new wheels may be procured, or the broken parts fastened so that the engine may proceed carefully home. The back wheel of an engine-truck can be chained up securely to a rail or cross-tie placed across the top of the engine-frame. If an accident happens to the front wheels, and it proves impracticable to get a sound pair, the truck should be turned round when a side track is reached. An accident to the wheels or axle of a tender-truck can be managed in the same way as an engine-truck, but the cross-beam to support the chained weight must be placed across the top of the tender. A bent axle or broken wheel that prevents a truck from following the rail, can be run to the nearest side track by fastening the wheels so that they will slide on the rails.

## BROKEN DRIVING AXLES, WHEELS, AND TIRES.

Accidents of this nature often disable the engine entirely; but sometimes the breakage occurs in such a way that the engine can run itself home, or into a side track, by good and careful management. Driving-axles generally break in the box, or between the box and the wheel. When this happens to a main driving-axle, or when any thing happens to the forward driving-

wheel or tire of such a serious nature that the engine can not be moved until the wheel is raised away from the rail, the engineer's first duty is to take down the main rod on that side, and secure the piston, then to take down both of the side rods. Cases could be cited where engineers have brought in engines with broken axles without disconnecting any thing, but these men did not take the safe side by a long way.

The rods being disconnected, run the disabled wheel up on a wedge or block of wood, and secure it in the raised position by driving blocking between the axle-box and the pedestal-brace. To get the box high enough in the jaws, it is sometimes necessary to remove the spring and saddle from the top of the box. A wheel may break and not fall to pieces, but still be dangerous to use, except for moving along slowly. A tire may break, and yet remain on the wheel, only requiring the most careful handling. On the other hand, the breaking of a wheel or tire may render the wheel useless, when it must be raised from the rail the same way as was recommended for a broken axle, and the same precautions in regard to stripping that side of the engine must all be taken. In the event of an accident happening which disables both forward drivers, they must both be raised from the rails, and the engine pulled in, the truck and hind drivers supporting the weight. Both side-rods must come down.

The breaking of back driving-axles, or accidents to wheels or tires, is very difficult to manage; because the weight must be supported in some way. The first act when such a mishap occurs, is to take down both

side-rods. If the engine can be moved to the nearest side track without further change, take it there; now jack up the back part of the engine, and fasten two pieces of rail by chaining or otherwise to the frames of the engine, their ends resting on the tank-deck, so that, when the jacks are lowered, the tank will help to support the hind part of the engine.

I have seen a case where one piece of rail was pushed into the draw-bar casting, and it held the engine up through a journey of seventy miles. If one of the back driving-wheels can be used, it lessens the weight that has to be borne by any lever contrivance. When one wheel is disabled, it must be blocked up in the jaws; and, should both wheels be rendered useless, they must both be held up, so that as much as possible of the weight may be thrown upon the forward drivers.

## CHAPTER XIV.

### CONNECTING-RODS, SIDE-RODS, AND WEDGES.

#### CARE OF LOCOMOTIVE RODS.

WHEN it is found that an engineer runs his engine for months on arduous train service, and has no trouble with his rods, he may safely be credited with knowing his business, and attending to it skillfully. In regard to the keeping of the machinery in working-order, the engineer's duties are mostly of a supervisory nature. When piston-rings get blowing, when guides need closing, or when injectors get working badly, he reports the matter; and the work is done so that the defect is remedied. With the rods it is different. Although he does not file the brasses himself, he exerts great influence, for good or evil, in the way he manipulates the keys, and by the care he takes of the rods. Injudicious keying of rods is responsible for more accidents than the mistakes in any other one direction, with, perhaps, the exception of the current mistake of the hind brakeman, who supposes there is no use in going back to flag when his train has stopped between stations.

## FUNCTIONS OF CONNECTING-RODS.

The functions of rods being to transmit the motion of the pistons to the running-gear, they have very heavy duty to perform. The conflicting strains and shocks to which a locomotive is subjected while running over a rough track at high speed, are, in many instances, sustained by the rods: hence it is of special importance that this portion of the motion should be kept in good order. Main rods convey the power developed in the cylinders to the crank-pins by a succession of pulls and thrusts equal in vigor to the aggregate of steam-pressure exerted on the piston. To endure this alternating tension and compression without injury to the working-parts, it is of the utmost importance that the connections should be close fitted, yet free enough to prevent unnecessary friction. In fitting up main-rod brasses, it does not matter in what position the crank stands, so long as it is convenient for doing the work. But, if the engine has been in service since the pins were turned, they should be calipered through their horizontal diameter when the crank is on the center; since it is well known that the pins have a tendency to wear flat on the sides at right angles to the crank's length. The back ends of the main-rod brasses should be fitted brass to brass; for that form of doing the work makes the most secure job, and gives the connection all the advantages of a solid box, preventing the straps and brasses from being knocked out of shape by hammering each other,—a result that surely follows the open brasses method of

fitting back ends of main-rods. Leaving the forward end brasses a little open is not injurious to that connection, because the line of strain is not so varied as that of the back end.

#### EFFECTS OF BAD FITTING.

When the work of fitting a set of back-end brasses is completed, they should be put in the strap, and tried on the pin. If, after being keyed close together, they revolve on the pin without pinching, the fit is not too tight. It is of the greatest consequence, in fitting rod-brasses, to ascertain, beyond doubt, that the brasses have been bored out true, and that they fit in the strap so that the line of strain shall be in line with the cross-head and crank-pins. It occasionally happens, through bad workmanship, that when the back end of a rod is keyed up, and the front end not connected, the rod does not point straight to the cross-head pin, but in a line some distance to the right or left. The distance may be very small, yet sufficient to cause no small amount of trouble. By some pinching and jamming, a rod in this condition can be connected up; but it is almost sure to run hot. And a rod in this condition will never run satisfactorily till it is taken down and fitted by a competent machinist. The back end may be all right, and the forward end suffering from oblique fitting. This is even more common than the first case, and the effect is the same. A rod in this condition, besides displaying a tendency to run hot, will keep jerking the cross-head from side to side on the guides, and will probably make the cross-head

chafe the guides at certain points. Rods never run cool, and free from jar, unless they are fitted to transmit the power in a direct line between the pins.

#### STRIKING POINTS AND CLEARANCE.

Before putting up main rods, the striking points of the pistons should be located and marked on the guides. Then, when the rods are put up, the clearance should be divided equally between the two ends. The identification of these points is of greater interest to the engineer who is running the engine than to any other person; for upon their correctness the success of his running may, to some extent, depend. An engine may go out with the clearance badly divided, and run all right for a few days, and the driving of a key may then cause the piston to strike the head. A forcible instance of this kind once came under my observation. A careless machinist, in working on main-rod brasses, had mixed the liners, and shortened the rod, till the piston began to touch the back head. When the engine was working light, there was just a slight jar; but, when the load was heavy, the jar became a distinct pound. The engineer could not locate the knock, and was disposed to think it was in the driving-box. One day that he slipped the engine badly, steam began to issue from the back cylinder-head, which was cracked by a blow from the piston. The cause of the pound was then discovered. When by a blunder of this kind the piston is permitted to lap over the counter-bore it will nearly always result in the packing-rings getting torn so that they break.

## WATCHING RODS ON THE ROAD.

When an engineer starts out with an engine after the rod-brasses have been filed, he should make them a special object of attention. If he cannot shake the connection laterally with his hands when there is room for movement within the collars, he should slack up the key till he can do so; for some one has made a mistake in fitting. So long as the rod passes the center without jar when the engine is working hard in full gear, the brasses are tight enough. After running a few miles with newly fitted brasses, the rod will generally need keying up; for liners that were comparatively loose when put up, get driven compactly together, leaving lost motion. Although a connection may be put together brass to brass, there is still some work left for the engineer to do in the way of keying. To do keying correctly needs considerable sagacity, especially in the case of side-rods. In the case of back ends of main rods, the key should be got down as soon as possible, to hold the brasses immovably in the strap; but, after this point is reached, there should be no more hammering on the key. Some men persist in pounding down keys that are already snug, and the effect of their blows is to spring the brass out of shape. A key acts as a wedge, which it is; and, when the taper is slight, the blow imparted by a hammer roughly used, exerts an immense force in driving it down. Something must yield; and the brass gets sprung towards the pin, presenting a ridge for a rubbing surface, which heats, and causes delay. After



the key is once driven tight home, its work is finished. If the pin then indicates lost motion, the rod should be taken down, and the brasses reduced. In the case of main rods, this should be done at the first signs of pound; for lost motion entails heavy shock upon the moving parts. The front end of main rods requires to be very carefully watched, and the connection kept free from jar. Where this part is kept regularly oiled, and free from lost motion, it gives scarcely any trouble; but let the wrist-pin of the common cross-head once get cut through neglect, and it is a difficult matter getting it in good running-order again. The style of cross-head where the pin is part of the casting, although greatly used, is a most awkward article to fit up and keep in shape. The form of cross-head which works between two guide bars, and has its axis in line with the piston-rod, is becoming deservedly popular.

#### SIDE-RODS.

Many attempts have been made to dispense with side-rods, and they certainly are a troublesome part of the machinery to keep right; but no better means of connecting driving-wheels has yet been devised. The first method of coupling driving-wheels together, so that more than one pair might be available for adhesion, was by means of cogs and gearing. This was improved on by an endless chain working over pocketed pulleys; but even this was an extremely crude device, —working with tumultuous jerks, and a noise like a stamping-mill. One of the first real improvements, which George Stephenson effected on the locomotive,

was the inventing of side-rods. An essential element in locomotive construction needed to make side-rods run with safety, is, that all the wheels connected shall be of the same circumference. There is a practice on some roads of putting new tires on wheels just as they come from the rolling-mill, without putting them in the lathe. Such tires are seldom accurate in size; and they cause no end of trouble, especially to side-rods. This is one of the economical practices that does not pay.

#### ADJUSTMENT OF SIDE-RODS.

To connect driving-wheels so that they will run together in perfect harmony, after ascertaining that they are the same size, the next point is to secure the crank-pins at an equal distance from the centers of the wheels. When this is done, and the wheels are trammed parallel to the line of motion, the rods will move on a plane with the centers of the crank-pins exactly the same distance apart as are the centers of the driving-axles. The rods can be adjusted to the greatest advantage with the steam raised, so that the heat of the boiler will make the frames about the same length as when the engine is at work. The expansion due to the heat of the boiler is short when measured by a foot-rule, but it affects the smooth action of the side-rods to a remarkable extent.

Before tramping for the side-rods, it is necessary to have the driving-box wedges set up just tight enough to let the driving-boxes move vertically in the jaws without sticking. The distance between the centers

of the driving-axles and the centers of the crank-pins having now been found equal, the rods are fitted up; each connection being secured a close fit to the pin, with the brasses held brass to brass. With the brasses bored out exactly to the size of the crank-pins, and the rods accurately fitted, a connection could be made which would bind the two sets of drivers to move as an unbroken unit, were it not for the disturbing element which appears in the shape of rough track. With uneven track and worn wheel-tires, a tremendous tension is put on the rods where the connections are closely fitted. Provision is made for this source of danger by leaving the brasses of the back pins loosely fitted. A yielding space is left between the brass and the pin, not between the brass and the key or strap. The latter connections must be perfectly snug, or the strap will soon be pounded out of shape.

In the case of ten-wheel and consolidation engines, the brasses of all wheels behind the leading pair should be bored out one-sixty-fourth larger than the pins, which will generally be sufficient. In case a pin is sprung,—which is no rare circumstance,—room enough must be left in the brass to let the pin pass over its tightest point without pinching. The center is the proper position to put up side-rods on. Some men like to fit side-rods with the cranks on the eighths position; holding that there the greatest strain comes on, and, consequently, that there fitting up should be done. That is a mistaken idea; for rods may be put together on the eighths, and yet bind the pins badly in passing the centers. On the other hand, if they

pass the centers easily, they will go round the remainder of the circle without danger.

#### KEYING SIDE-RODS.

When it is necessary for an engineer to key up side-rods, he should select a place where the track is straight, and as even as possible. Then he should put the cranks on the center, and take care that he can move the connections laterally after the job is done. If he now moves the engine so that the cranks are on the other center, and finds that the rod connections can still be moved, that side is all right. If the other side be treated in a similar manner, his rods are not likely to give trouble. With a worn-out engine and rough road-bed, it is a difficult matter to preserve the true mean between loose and tight side-rod connections. But, in a case of doubt, the loose side is the safe side. Yet most engineers are inclined to err on the side of danger, for they will generally tighten up the rods to prevent them from rattling. On a Western road, where solid-ended brasses were adopted, it was often amusing to hear the engineers protesting against the noise the side-rods made when the brasses began to get worn. They would rattle from one end of the division to the other; but they would not break pins, or fracture themselves, and tear the cab to pieces, or ditch a train, as happens so often from other rods being keyed to prevent noise. Sprung crank-pins and broken side-rods are very often the result of injudicious keying.

## DIFFICULTY IN LOCATING DEFECTS.

A locomotive has so many parts that bear a close relation to each other, and that are so sympathetic when one of the parts becomes disordered, that it is sometimes a difficult matter to immediately locate a complaint. One of the signs of a defect, in many of the parts, or one of the consequences of it, is a "pound,"—a complaint that we hear of in a locomotive about as frequently, and with the same feeling, as we do of malaria in the individual.

## POUNDING IN DRIVING-BOXES AND WEDGES.

But we will deal now with the pounds in a locomotive, and will take the location in which we find the most and serious ones,—namely, in the driving-boxes and wedges,—and see why they pound, and what will prevent them from doing so. The cause we will find, if in the wedges, is due to a rocking of the box in them, or from causes arising from imperfect fitting when they were put up, or lined up when the engine was in the shop. This fitting of wedges on a locomotive that has done service is a matter of importance in the immediate present and future working of the parts themselves, and of other parts of the locomotive as well. On stripping a locomotive that has done much service, it will be found that the working of the wedges on the face of the pedestal has worn it hollow, or pounded furrows on it, or has done both. This occurs so frequently on the "live" wedge side, that it may be taken as the rule, rather than the exception, to find

the pedestal in this condition. While it does not happen so frequently on the "dead" wedge side as on the other, it will be found there also if the wedge has not been held by a fastening to the pedestal, or securely fitted between the top of the frame and the pedestal binder brace. These defects will be found on the back of the wedge also, and are produced by the same cause and same motion as those on the pedestal face. These defects are the most frequent cause of the driving-box pounding, or of the wedges rocking; since thereby the wedges get thrown out of parallel to each other, when it becomes necessary to adjust them during the service of the locomotive.

In refitting wedges, these defects should be removed, the pedestal face carefully straightened its entire length, and the wedge-back fitted to it. It is not only necessary that the pedestal face should be smooth, but that it should be straight its entire length. If not, when it becomes necessary to adjust the wedge, if the pedestal is high on the top end, the wedge is thrown out at the top, binding the box at that point, and allowing it to swing at the bottom.

#### IMPORTANCE OF HAVING WEDGES PROPERLY FITTED.

With the pedestal face in a proper condition to avoid displacement of the wedge, when moved to different positions on it, we should consider what will be the method of lining the wedges, and what duty they have to perform. This duty is merely to take up the lost motion between the pedestal and boxes; and that, from their shape, they readily do from time to

time. While this duty is simple, the wedges ought to do it without affecting any of the other parts of the locomotive,—a condition of perfection that can be reached only by having all the wedges perfectly parallel with the pedestals and with each other. If the first condition is not complied with, the result, as stated, will be the box swinging in the wedges. If the latter, then with the varying position of the boxes in the pedestal due to the engine settling on the springs, or to the change of position from the motion of the springs when the locomotive is running, we will have a varying distance between the centers of the wheels and length for the side-rods.

Many of the complaints we hear of rods not working properly are owing to this defect in wedges not being parallel, by which the distances are varied, and a strain thrown upon the rods that not only affects them, but causes them in turn to bind the boxes against the wedges by trying to compress or extend to a length varying as often as the motion of the springs. While the motion of the springs is not much in proportion to the length of the wedges, and the varying distance between centers of wheels is in ratio to that proportion, if the wedges are not parallel, we must remember how often the motion is occurring, and that, no matter how slight the strain upon the rods may be, we are putting it on a part of the locomotive that requires the minutest adjustment to enable it to do its work properly and safely.

## INFLUENCE OF HALF-ROUND BRASSES.

Driving-boxes fitted with a half-round brass have a tendency to close at the bottom. This tendency is continuous, and becomes most marked as the brass wears down, relieving the box of the strain put upon it by the tight-fitting brass. With a properly fitted brass, and a collar put up in good shape, the box can not close much: still, there will be enough looseness to cause a slight pounding. During the first few days' service of a locomotive after new driving-brasses of this shape are put in, the compression on the brass, resulting from the weight of the engine, tends to close the bottom of the box, and permits the box to rock. This evil may be, to some extent, prevented by fitting the wedges slightly closer at the bottom. This closing of the box at the bottom is not only an evil and annoyance in itself by causing pounding, but is a further source of trouble by hastening the forming of a shoulder on the top of the wedge. The tendency at all times is for the axle-box to wear a shoulder at the top and bottom of its travel, even when the box retains its proper shape; but, when it is distorted by closing at the bottom, the rubbing surfaces are put out of the true plane, and wear takes place much more rapidly. While the springs retain their position, and impart to the axle-box a fixed range of motion, no serious effect is felt from the worn wedges. But when the locomotive is passing over rough frogs or bad rail-joints, where the motion of the spring is increased, the frame pounds down upon the box, which for a moment



becomes fastened in the narrow space between the shoulders of the wedges; and an effort is needed for the box to relieve itself, and allow the spring to resume its motion. This causes the engine to ride hard in some instances, where the condition of the track makes the box catch frequently. Sometimes the box will be unable to relieve itself without assistance, and much loss of time and annoyance result when the wedge has to be pulled down to relieve the box.

The forming of the shoulder on top and bottom of the wedge may be anticipated and prevented by planing the part where the ridges form, leaving a face just the length of the box plus the space covered by the motion of the springs. Not only does this aid in preventing the box from forming a shoulder, but it also reduces the first cost of fitting the wedges by reducing the surface to be squared and finished true.

#### POSITION OF BOXES WHILE SETTING UP WEDGES.

With the wedges in a proper condition when the locomotive enters service, we yet must care for them and adjust them from time to time, when it is necessary to take up the lost motion between the pedestals and boxes. When doing this work, it is important that the position and condition of the driving-box should be considered. The position of the box should be such that the wedge may be set up to the proper degree of tightness with certainty and without much labor. It is important that a wheel position be found where the box would not be moved by the wedge when the latter is being adjusted. This position will

be found where the box is up against the dead wedge, since the lost motion will then be between the box and the wedge to be moved. To get all the driving-boxes in that position at one time is a difficult matter, if it is to be done by pinching the wheels. The position of the rods decides the direction of their action on the wheel by the thrust or pull upon the crank-pin. If the rod is above the wheel center, pinching behind the back wheel will force both the wheels and boxes on that side up against the dead wedge; but, should the rod be below the wheel center, similar work with the pinch-bar will draw the forward box away from the dead wedge, the side rod doing this by pulling on the crank-pin,—this is always supposing the dead wedge to be in the front pedestals. The best position, therefore, to get an engine into for setting up all the wedges, is with the side-rods on the upper eighths; for then pinching behind the back wheels will push all the boxes up to the dead wedges. The work can then be done without putting unnecessary strain upon the wedge-bolts, which are often found with the corners of the heads rounded off, and the thread injured to such an extent that it will not screw through the binder-brace,—a condition of matters nearly always caused by trying to force up wedges without putting the engine in the proper position. If the wedge-bolt, from faulty construction, or through injury, is unable to move up the wedge, driving is resorted to, by which means it is battered on the end; and the jarring of each blow causes the ashes and dirt on top to fall behind the wedge, throwing it out of parallel, and intro-

ducing material that will cause the wedge to cut. The ashes and dirt that accumulate so readily on the top of wedges and boxes cause no end of trouble, although the fact is not generally recognized; and it will generally be fruitful labor to have these parts well cleaned off before beginning to set up wedges. Many complaints that are made of wedges not being properly adjusted, proceed from the disturbance that follows grit introduced between the wedge and box.

#### NECESSITY FOR KEEPING BOXES AND WEDGES CLEAN.

The growing practice of close and stated inspection of locomotives to detect defects, before waiting for them to develop into breakages that cause trouble and delay to trains, will give especially good results if applied to boxes and wedges. If the wedges are taken down and examined at regular intervals, the ridges that appear so readily on the face, when oil-grooves are cut on the sides of the driving-box, can be smoothed off before they cause distortion of the surface. This is also a good time for a thorough cleaning of the pedestals and box, and the oil-holes can be examined and opened out properly. Work of this kind often prevents boxes getting hot on the road, with all the entailed delay and expense, which frequently include changing engines if the train must be pushed on. One turn of a hot box will often wear a brass more than the daily running for two years.

## TEMPERATURE OF THE BOX TO BE CONSIDERED.

One condition of the box to be considered, when adjusting wedges, is its temperature at the time the work is done, and what that will be when the engine is in service. Adjusting wedges is often done as a preliminary step in lining and adjusting side-rods; and this is done on many roads on the shop-day when the locomotive is in for washing-out and periodical repairs. At that time, the engine being cold, the boxes will be at their lowest temperature, and, consequently, at their smallest dimensions. Allowance should then be made with the wedges for some expansion of the boxes. Another condition that should be considered, is how the box has been running. A box that has been running hot or warm, generally compels the wedge to be lowered to allow for extra expansion. When this box has been repacked, or otherwise cared for, the wedge is again set up. While doing this, it should be remembered that a box that has been running hot is liable to be distorted, and its journal bearing injured, so that it is likely to run warm for some time, till the brass comes to a smooth bearing. If the wedge will not permit the box to expand, it binds the journal, and is likely to run still hotter, and is liable to stick in the jaws.

## SMALL DISORDERS THAT CAUSE ROUGH RIDING.

Many complaints are made about pounds in driving-boxes and wedges, when the trouble really exists elsewhere. Boxes with driving-spring saddles whose foot

is but the width of the top or spring-band, will oft-times, if the band is not rounded where it rides on the saddle, or is not fitted with a pin or other center bearing, tip on the box with each motion of the spring. Or, if the saddle is moved from its worn seat on the top of the box, it will rock and pound. Again, obstructions in the bearing of the spring equalizer that will prevent the full motion of the springs, and bring them to a sudden stop, will produce a motion resembling that caused by a stuck box. Attention to details that are sometimes considered the crude parts of a locomotive, will often prove highly beneficial to the working of the locomotive; and especially is this the case with the parts that transmit the motion of the springs.

## CHAPTER XV.

### THE VALVE-MOTION.

#### THE LOCOMOTIVE SLIDE-VALVE.

THE nature of the service required of locomotive engines, especially those employed on fast-train service, makes it necessary that the steam-distribution gear shall be free from complication; and, for convenience in working the engine, it is essential that means should be provided for reversing the motion promptly without endangering the working-parts. The valve-gear should also be capable of regulating the admission and exhaust of steam, so that the engine shall be able to maintain a high rate of speed, or to exert a great tractive force. These features are admirably combined in the valve-gear of the ordinary locomotive. Designers of this form of engine have given great consideration to the merit of simplicity. Numerous attempts have been made to displace the common D slide-valve, but every move in that direction has ended in failure.

#### INVENTION AND APPLICATION OF THE SLIDE-VALVE.

The slide-valve, in a crude form, was invented by Matthew Murray of Leeds, England, towards the end

of last century; and it was subsequently improved by Watt to the D form. It received but little application in England till the locomotive era. Oliver Evans of Philadelphia appears to have perceived the advantages possessed by the slide-valve, for he used it on engines he designed years before locomotives came into service. The D slide-valve was better adapted for high-speed engines than anything tried during our early engineering days, but it was on locomotives where it first properly demonstrated its real value. The period of necessity brought the slide-valve into prominence; and the galaxy of mechanical genius that heralded the locomotive into successful operation recognized its most valuable features, and it soon obtained exclusive possession of that form of engine. Through good and evil report, and against many attempts to displace it, the slide-valve has retained a monopoly of high-speed reversible engines.

#### DESCRIPTION OF THE SLIDE-VALVE.

The slide-valve in common use is practically an oblong cast-iron box, which rests and moves on the valve-seat. In the valve-seat, separated by partitions called bridges, are three ports, those at the ends being the openings of the passages for conveying steam to and from the cylinders, while the middle port is in communication with the blast-pipe, which conveys the exhausted steam to the atmosphere. On the under side of the valve is a semicircular cavity, which spans the exhaust-port and the bridges when

the valve stands in its central position. When the steam within the cylinder has performed its duty of pushing the piston towards the end of the stroke, the valve cavity moves over the steam-port, and allows the steam to pass into the exhaust-port, thence into the exhaust-pipe. The cavity under the valve thus acts as a door for the escape of the exhaust steam. This is a very convenient and simple method of educting the steam; and the process helps to balance the valve, since the rush of escaping steam striking the under part of the valve tends to counteract the pressure that the steam in the steam-chest continually exerts on the top of the valve.

## PRIMITIVE SLIDE-VALVE.

In its primitive form the slide-valve was made merely long enough to cover the steam-ports when placed in the central position, as shown in Fig. 6.

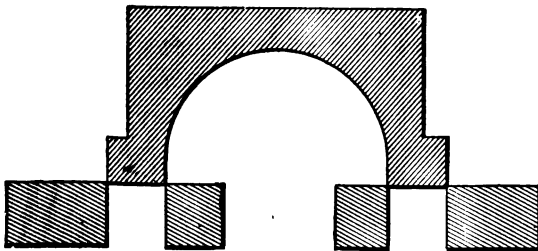

Quarter Sise.

FIG. 6.

With a valve of this form, the slightest movement had the effect of opening one end so that steam would be admitted to the cylinder, while the other



end opened the exhaust. By such an arrangement steam was necessarily admitted to the cylinder during the whole length of the stroke; since closing at one end meant opening at the other. There were several serious objections to this system. It was very difficult to give the engine cushion enough to help the cranks over the centers without pounding, and a small degree of lost motion was sufficient to make the steam obstruct the piston during a portion of the stroke. But the most serious drawback to the short valve was that it permitted no advantage to be taken of the expansive power of steam. For several years after the advent of the locomotive the boiler-pressure used seldom exceeded fifty pounds to the square inch. With this tension of steam there was little work to be got from expansion with the conditions under which locomotives were worked; but, so soon as higher pressures began to be introduced, the loss of heat entailed by permitting the full-pressure steam to follow the piston to the end of the stroke became too great to continue without an attempted remedy. A very simple change served to remedy this defect and to render the slide-valve worthy of a prominent place among mechanical appliances for saving power.

#### OUTSIDE LAP.

The change referred to, which so greatly enhanced the efficiency of the slide-valve, consisted in lengthening the valve-face, so that, when the valve stood in the center of the seat, the edges of the valve extended a certain distance over the induction ports, as

in Fig. 7. This extension of the valve is called outside lap, or simply lap. The effect of lap is to close the steam-port before the piston reaches the end of the stroke, and the point at which the steam-port is closed is known as the point of cut-off. When the steam is cut off and confined within the cylinder, it pushes the piston along by its expansive energy, doing work with heat that would be lost were the cylinder left in communication with the steam-chest till the end of the stroke.

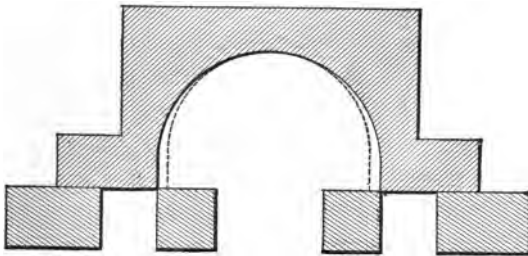

Quarter Size

FIG. 7.

When a slide-valve is actuated by an eccentric connected directly with the rocker-arm or valve-stem, the point of cut-off caused by the extent of lap, remains the same till a change is made on the valve, or on the throw of the eccentric, unless an independent cut-off valve be employed. Locomotives having the old hook motion worked under this disadvantage; because the hook could not vary the travel of the valve, which is the method usually resorted to for producing a variable cut-off. The link and other simple expansion gears perform their office of varying the cut-off in this way.

## SOME EFFECTS OF LAP.

In addition to cutting off admission of steam before the end of the stroke, lap requires the valve to be set in such a way that it has also the effect of leading to the exhaust-port being opened before the end of the stroke. The point where the exhaust is opened is usually known as the point of release. The change which causes release to happen before the piston completes its stroke, leads to the closure of the exhaust-port before the end of the return-stroke is reached, which imprisons the steam remaining in the cylinder, causing compression. Where a valve has no inside lap, release and compression happen simultaneously; that is, the port at one end of the cylinder is opened to release the steam, and that at the other end is closed, letting the piston compress any steam remaining in the cylinder into the space left as piston clearance.

## INSIDE LAP.

In some cases the inside edges of the valve cavity do not reach the edges of the steam-ports when the valve is on the middle of the seat, but lap over on the bridge a certain distance, as shown by the dotted lines in Fig. 7. This is called inside lap, and its effect upon the distribution of steam is to delay the release. By this means it prolongs the period of expansion, and hastens compression on the return stroke. Inside lap is an advantage only with slow-working engines. When high speed is attempted with engines having

much inside lap, the steam does not have enough time to escape from the cylinders, and the back pressure and compression become so great as to be very detrimental to the working of the engine. As locomotive engineers have it, the engine is "logy."

#### THE EXTENT OF LAP USUALLY ADOPTED.

In locomotive practice, the extent of lap varies according to the character of service the engine is intended to perform. With American standard gauge engines, the lap varies from  $\frac{1}{8}$  inch to  $1\frac{1}{4}$  inch. For high-speed engines, the extent of lap ranges from  $\frac{1}{8}$  to  $1\frac{1}{4}$ . Freight engines commonly get  $\frac{5}{8}$  to  $\frac{3}{4}$  outside lap, and from  $\frac{1}{8}$  to  $\frac{1}{4}$  inside lap. With a given travel, the greater the lap the longer will the period for expansion be.

#### FIRST APPLICATION OF LAP.

Lap was applied to the slide-valve in this country before its advantage as an element of economy was understood in Europe. As early as 1829, James of New York used lap on the valves of an engine used to run a steam-carriage; and in 1832 Mr. Charles W. Copeland put a lap-valve on a steamboat engine, and his father understood that its advantage was in providing for expansion of the steam. Within a decade after our first steam-operated railroad was opened, the lap-valve became a recognized feature of the American locomotive; but the cause of the saving of fuel, effected by its use, was not well comprehended. Many enlightened engineers attributed the saving to

the early opening of the exhaust, brought about where outside lap was used, which they theorized reduced back pressure on the piston; and in that way they accounted for the enhanced economy resulting from the application of lap. It was not till Colburn applied the indicator to the locomotive, that the true cause of economy was demonstrated to be in the additional work taken from the steam by using it expansively.

#### THE ALLEN VALVE.

An improvement on the plain *D* slide-valve has been effected in a simple and ingenious manner in the Allen valve, which is receiving considerable favor for high-speed locomotives. This valve is shown in Fig. 8. The valve has a supplementary steam-passage, *A*,

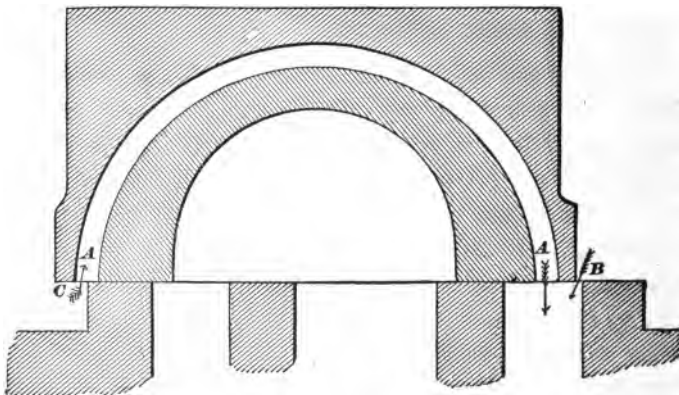

FIG. 8.

*A*, cast above the exhaust cavity. The valve and seat are so arranged, that, so soon as the outside edge of

the valve begins to uncover the steam-port at *B*, the supplementary passage begins receiving steam at *C*; and this gives a double opening for the admission of steam to the port when the travel is short. As the travel of the valve is always short when an engine is running at high speed, the advantage of this double opening is very great; for it has the effect of admitting the steam promptly at the beginning of the stroke, and maintaining a full pressure on the piston till the point of cut-off.

#### ADVANTAGES OF THE ALLEN VALVE.

With an ordinary valve cutting off at six inches, and having five inches eccentric throw, the port opening seldom exceeds  $\frac{3}{8}$  inch. It is a hard matter getting the full pressure of steam through such a small opening in the instant given for admission. If an Allen valve is used with that motion, the opening will be double, making  $\frac{3}{4}$  inch, which makes an important difference. The practical effect of a change of this kind is that an engine will take a train along, cutting off at six inches with the Allen valve, when, with the ordinary valve, the links would have to be dropped to eight or nine inches. The valve can be designed to work on any valve-seat, but the dimensions given in Fig. 8 are those that have been found most satisfactory with our large passenger engines. In designing an Allen valve for an old seat, it is sometimes advisable to widen the steam-ports a quarter of an inch or more, by chamfering off the outside edges that amount. Care must be taken to prevent the valve

from traveling so far as to put the supplementary port over the exhaust-port, for that would allow live steam to pass through. The proper dimensions can best be schemed out on paper before making the required change on the seat.

#### DISADVANTAGES OF THE ALLEN VALVE.

The disadvantages of the Allen valve are that it requires care and attention in setting and adjustment. The valve gives practically double-lead opening; but through the blunder of having the opening at *C* too great at the beginning of the stroke many locomotives have suffered so much from excessive lead that the Allen valve has been abandoned as a failure. In other cases there was no opening at *C* when the piston was beginning the stroke. Failures of a device because those in charge were deficient in common sense is an old story.

#### CASE WHERE THE ALLEN VALVE PROVED ITS VALUE.

On one of the leading railroads in this country, an engineer was running a locomotive on a fast train where it was a hard matter making the card-time. A few minutes could be saved by passing a water-station; but this was done at serious risk, for the tender would nearly always be empty by the time the next water-station was reached. The master mechanic of the road determined to equip this engine with the Allen valve: and, after the change was made, there was no risk in passing the water station; for there always was a good margin of water in the tank when the next

watering-place was reached. The engine seemed to steam better, because the work was done with less steam; and there was a decided saving of fuel. The change made the engine smarter, and there seems to be no limit to the speed it can make. This valve can be applied to any locomotive with trifling expense. When an engine is designed specially for the Allen valve, the steam ports and bridges are usually made a little wider than for the ordinary valve. The only real difficulty in adopting the valve is getting the casting properly made, so that the supplementary port will not be too rough for the passage of steam, and the thin shell will be strong enough to stand the pressure.

#### INSIDE CLEARANCE.

For high-speed locomotives, where there is great necessity for getting rid of the exhaust steam quickly, the valves are sometimes cut away at the edges of the cavity, so that, when the valve is placed in the middle of the seat, it does not entirely cover the inside of either of the steam-ports. This is called inside clearance. In many instances inside clearance has been adopted in an effort to rectify mistakes made in designing the valve-motion, principally to overcome defects caused by deficiency of valve-travel. The fastest locomotives throughout the country do not require inside clearance, because their valve-motion is so designed that it is not necessary. Inside clearance induces premature release, and diminishes the period of



expansion. Consequently inside clearance wastes steam, and ought to be avoided.

#### LEAD.

There are certain advantages gained, in the working of a locomotive, by having the valves set so that the steam-port will be open a small distance for admission of steam, when the piston is at the beginning of the stroke. This opening is called lead. On the steam side of the valve the opening is called steam-lead: on the exhaust side it is called exhaust-lead. Lead is generally produced by advancing the eccentric on the shaft, its effect being to accelerate every event of the valve's movement; viz., admission, cut-off, release, and compression. In the most perfectly constructed engines, there soon comes to be lost motion in the rod connections and in the boxes. The effect of this lost motion is to delay the movement of the valves; and, unless they are set with a lead opening, the stroke of the piston would in some instances be commenced before steam got into the cylinder. It is also found, in practice, that this lost motion would cause a pounding at each change in the direction of the piston's travel, unless there is the necessary cushion to bring the cranks smoothly over the centers. Without cushion, the change of direction of the piston's travel is effected by a series of jerks that are hard on the working-parts. So long as the lead opening at the beginning of the stroke is not advanced enough to produce injurious counter-pressure upon the piston, it improves the working of the engine by causing a prompt opening

for steam admission at the beginning of the stroke. This is the time that a full steam-pressure is wanted in the cylinder, if economical working be a consideration. A judiciously arranged lead opening is therefore an advantage; since it increases the port opening at the proper time for admitting steam, tending to give nearly boiler-pressure in the cylinder at the beginning of the stroke. With the shifting link-motion, the amount of lead opening increases as the links are hooked back towards the center notch; the magnitude of the increase, in most cases, being in direct proportion to the shortness of the eccentric-rods. A common lead opening in full gear with the shifting link is  $\frac{1}{16}$  inch, which often increases to  $\frac{3}{8}$  inch in the center notch. The tendency of wear and lost motion is to neutralize the lead, so that when a locomotive motion gets worn, increasing the lead will generally improve the working of the engine.

#### NEGATIVE LEAD.

Lead opening, however, has its disadvantages. When the eccentric-rods are short the lead opening increases so rapidly, as the links are notched up towards the center, that it has become the custom on some roads to set the valves of high-speed engines lapping all over the port at the beginning of the stroke. This practice is called setting the valves with negative lead, and it increases the efficiency and power of the engine when running very fast. It is very common to find the valves set with  $\frac{1}{16}$  inch negative lead.

## OPERATION OF THE STEAM IN THE CYLINDERS.

As the work performed by a steam-engine is in direct proportion to the pressure exerted by the steam on the side of the piston which is pulling or pushing on the crank-pin, it is important that the steam should press only on one side of the piston at once. Hence, good engines have the valves operated so that, by the time a stroke is completed, the steam, which was pushing the piston, shall escape and not obstruct the piston during the return stroke, and so neutralize the steam pressing upon the other side. When an engine is working properly, the steam is admitted alternately to each side of the piston; and its work is done against a pressure on the other side not much higher than that of the atmosphere.

## BACK PRESSURE IN THE CYLINDERS.

When, from any cause, the steam is not permitted to escape promptly and freely from the cylinder at the end of the piston stroke, a pressure higher than that of the atmosphere remains in the cylinder, obstructing the piston during the return stroke, and causing what is known as back pressure. There is seldom trouble for want of sufficient opening to admit steam to the cylinders, for the pressure is so great that the steam rushes in through a very limited space; but, when the steam has expanded two or three times, its pressure is comparatively weak, and needs a wide opening to get out in the short time allowed. This is one reason why the exhaust-port is made larger than the admis-

sion-ports. Nearly all engines with short ports suffer more or less from back pressure, but the most fruitful cause of loss of power through this source is the use of extremely contracted exhaust nozzles. Were it not for the necessity of making a strong artificial draught in the smoke-stack, so that an intense heat shall be created in the fire-box, quite a saving of power, now lost by back pressure, would be effected by having the exhaust opening as large as the exhaust-pipe. This not being practicable with locomotives, engineers should endeavor to have their nozzles as large as possible consistent with steam-making.

Engines with very limited eccentric throw will often cause back pressure when hooked up, through the valve not opening the port wide enough for free exhaust.

Locomotives suffering from excessive back pressure are nearly always logy. The engine can not be urged into more than moderate speed under any circumstances; and all work is done at the expense of lavish waste of fuel, for a serious percentage of the steam-pressure on the right side of the piston is lost by pressure on the wrong side. It is like the useless labor a man has to do turning a grindstone with one crank, while a boy is holding back on the other side. The weight of obstruction done by the boy must be subtracted from the power exerted by the man to find the net useful energy exerted in turning the grindstone. In the same way, every pound of back pressure on a piston takes away a pound of useful work done by the steam on the other side.

Excessive lead opening acts in the same way, since it lets steam into the cylinder to obstruct the piston before it reaches the end of the stroke.

#### EFFECT OF TOO MUCH INSIDE LAP.

Engines that have much inside lap to the valves are likely to suffer from back pressure when high speed is attempted. The inside lap delays the release of the steam; and, where the piston's velocity is high, the steam does not escape from the cylinder in time to prevent back pressure.

#### RUNNING INTO A HILL.

Most of engineers are familiar with the tendency of some engines to "run into a hill." That is, so soon as a hill is struck, they suddenly slow down till a certain speed is reached, when they will keep going. This is generally produced by back pressure, its obstructing effect being reduced when the engine is moving slow. The cause is nearly always too much lead-opening.

#### COMPRESSION.

The necessity which requires lap to be put on a slide-valve to produce an early cut-off, in its turn causes compression, by the valve passing over the steam-port, and closing it entirely for a limited period towards the end of the return stroke. As the cylinder contains some steam which did not pass out while the exhaust-port was open, this is now squeezed into a diminishing space by the advancing piston. In cases

where too much steam was left in the cylinders through contracted nozzles or other causes, or where, through mistaken designing of the valve-motion, the port is closed during a protracted period, the steam in the cylinder gets compressed above boiler tension, and loss of useful effect is the result. Under proper limits, the closing of the port before the end of the stroke, and the consequent compression of the steam remaining in the cylinder, have a useful effect on the working of the engine by providing an elastic cushion, which absorbs the momentum of the piston and its connections, leading the crank smoothly over the centre. Where it can be so arranged, the amount of compression desirable for any engine is the degree that, along with the lead, will raise the pressure of the cylinder up to that of the boiler at the beginning of the stroke. When this can be regulated, the compression performs desirable service by cushioning the working-parts, thereby preventing pounding, and by filling up the clearance space and steam passages, by that means saving live steam. Compression probably does some economical service by reheating the cylinder, which has a tendency to get cooled down during the period of release, and by re-evaporating the water, which forms by condensation of steam in the cool cylinder.

Engines that are running fast require more cushioning than those that run slow, or at moderate speeds. The link-motion, by its peculiarity of hastening compression when the links are hooked up, tends to make compression a useful service in fast running.

## DEFINITION OF AN ECCENTRIC.

The reciprocating motion which causes the valves to open and close the steam-ports at the proper periods, is, with most locomotives, imparted from eccentrics fastened upon the driving-axle. An eccentric is a circular plate, or disk, which is secured to the axle in such a position that it will turn round on an axis which is not in the center of the disk. The distance from the center of the disk to the point round which it revolves is called its eccentricity, and is half the throw of the eccentric. Thus, if the throw of an eccentric requires to be 5 inches, the distance between the center of the driving-axle and the center of the eccentric will be  $2\frac{1}{2}$  inches. The movement of an eccentric is the same as that of a crank of the same stroke, and the eccentric is preferred merely because it is more convenient for the purposes to which it is applied than a crank would be.

## EARLY APPLICATION OF THE ECCENTRIC.

On the early forms of locomotives, a single eccentric was used to operate the valve for forward and back motion. The eccentric was made with a half circular slot, on which it could be turned to the position needed for forward or back motion. It was held in the required position by a stop-stud fastened on the axle. Several forms of movable eccentrics were invented, and received considerable application during the first decade of railroad operating; but the best of them provided an extremely defective revers-

ing motion. The first engineer to apply two fixed eccentrics as a reversible gear was William T. James of New York, who made a steam carriage in 1829, and worked the engine with four eccentrics,—two for each side. The eccentrics were connected with a link, but the merits of that form of connection were not then recognized here; for it was not applied to locomotives till it became popular in England, and was reintroduced to this country by Rogers. The advantage of the double fixed eccentrics seemed, however, to be recognized from the time James used them; for the plan was adopted by our first locomotive builders. The first locomotive built by Long, who started in 1833 what was afterwards known as the Norris Locomotive Works, Philadelphia, had four fixed eccentrics.

#### RELATIVE MOTION OF PISTON AND CRANK, SLIDE-VALVE, AND ECCENTRICS.

When a locomotive is running, the wheels turn with something near a uniform speed; but any part which receives a reciprocating motion from a crank or eccentric travels at an irregular velocity. Fig. 9 shows the relative motion of the crank-pin and piston during a half revolution. The points in the path of the crank-pin marked *A*, 1, 2, *B*, 3, 4, *C*, are at equal distances apart. The vertical lines run from them to the points *a*, *b*, *c*, *d*, *e*, represent the position of the piston in relation to the position of the crank-pin. That is, while the crank-pin traverses the half-circle, *A B C*, to make a half revolution, the piston, guided by the cross-head,



travels a distance within the cylinder equal to the straight line  $AC$ . The crank-pin travels at nearly uniform speed during the whole of its revolution, but the piston travels with an irregular motion. Thus, while the crank-pin travels from  $A$  to  $I$ , the piston travels a distance equal to the space between  $A$  and  $a$ .

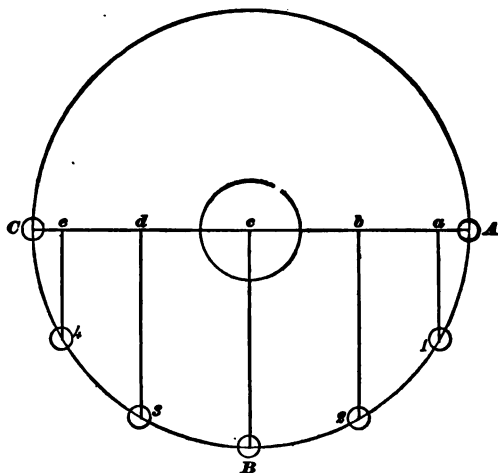

FIG. 9.

By the space between the lines, it will be seen that the piston travels slowly at the beginning of the stroke, gets faster as it moves along, reaches its highest velocity about half stroke, then slows down towards the end till it stops, and is ready for the return stroke.

#### ATTEMPTS TO ABOLISH THE CRANK.

Certain mechanics and inventors have been terribly harassed over this irregular motion of the piston, and

numerous devices have been produced for the purpose of securing a uniform motion to the power transmitted. These inventions have usually taken the shape of rotary engines. Probably the fault these people find with the reciprocating engine is one of its greatest merits, for the piston stopping at the end of each stroke permits an element of time for the steam to get in and out of the cylinder.

#### VALVE MOVEMENT.

The valve travels in a manner similar to the piston; although its stroke is much shorter, and its slow movement is towards the limit of travel. The small circle in the figure shows the orbit of the eccentric's center, and the valve-travel is equal to the rectilinear line across the circle. If the valve opened the steam-ports at the outside of its travel, the slow movement at that point would be an objection, since the operation of opening would be slow: but the valve opens the ports towards the middle of its travel, when its velocity is greatest; and, the nearer to the mid travel the act of opening is done, the more promptly it will be performed. This has a good deal to do with making an engine "smart" in getting away from a station.

#### EFFECT OF LAP ON THE ECCENTRIC'S POSITION.

With the short valve without lap used on the earliest forms of locomotives, the eccentric was set at right angles to the crank or "square" on the dotted line  $e$ , Fig. 10. The least movement of the eccentric from its middle position had the effect of opening the steam-

ports. One advantage about an eccentric set in this position, was that it opened and closed the ports when moving the valve at its greatest velocity. Lengthening the valve-face by providing lap entails a change in the location of the eccentric; for, were it left in the right-angle position, the steam-port would remain covered till the eccentric had moved the valve a distance equal to the extent of the lap on one end, and the piston would begin its stroke without steam.

#### ANGULAR ADVANCE OF ECCENTRICS.

The change made on the eccentric location is to advance it from  $e$  to  $F$ , being a horizontal distance equal

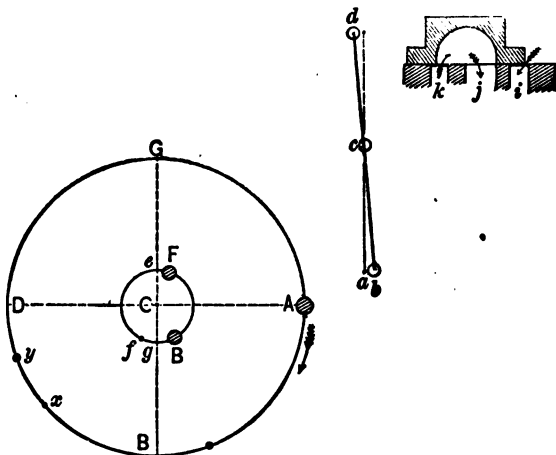

FIG. 10.

to the extent of lap and lead, and known as the angular advance of the eccentric. The centers  $F$  and  $B$  represent the full part, or "belly," of the forward and

back eccentrics in the position they should occupy, where a rocker is employed, when the piston is at the beginning of the backward stroke. It will be perceived that the eccentrics both incline towards the crank-pin, and the eccentric which is controlling the valve follows the crank-pin. Thus, when the engine is running forward, *F* follows the crank: when she is backing, *B* follows.

It is a good plan for an engineer to make himself familiar with the proper position of the eccentrics in relation to the crank, for the knowledge is likely to save time and trouble when anything goes wrong with the valve-motion. With this knowledge properly digested, a minute's inspection is always sufficient to decide whether or not anything is wrong with the eccentrics.

#### ANGULARITY OF CONNECTING-ROD.

In following out the relative motion of the piston and crank, we discover a disturbing factor in what is called the angularity of the connecting-rod, which has a curiously distorting effect on the harmony of the motion. When the piston stands exactly in the mid-travel point, the true length of the main rod will be measured from the center of the wrist-pin to the center of the driving-axle. If a tram of this length be extended between these points, this will be found correct, as every machinist accustomed to working on rods knows. Now, if the back end of the tram should be raised or lowered towards the points where the center of the crank-pin must be when the crank stands

on the top or bottom quarter, it will be found that the tram point will not reach the crank-pin center, but will fall short a distance in proportion to the length of the main rod. The dotted lines  $a'$  and  $b'$  in Fig. 11 show

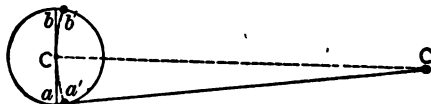

FIG. 11.

how far a rod  $7\frac{1}{2}$  times the length of the crank falls short. A shorter rod will magnify this obliquity, while a longer rod will reduce it.

#### EFFECT ON THE VALVE-MOTION OF CONNECTING-ROD ANGULARITY.

As the opening and closing of the steam-ports by the valves are regulated by the eccentrics, which are subject to the same motion as the crank, following it at an unvarying distance, it is evident that their tendency will be to admit and cut off steam at a certain position of the crank's movement. If the motion is planned to cut off at half stroke, it will be apparent, that, in the backward stroke, the piston will be past its mid-travel before the crank-pin reaches the quarter, so that end of the cylinder will receive steam during more than half the stroke. On the forward stroke of the piston, however, the crank-pin will reach the quarter before the piston has attained half travel; the consequence being, that in this case steam is cut off too early. The disturbing effect of the angularity of the connecting-rod on the steam distribution thus tends

to make the cut-off later in the backward stroke than in the forward stroke, resulting in giving the forward end of the cylinder more steam than what is admitted in the back end. The link-motion provides a convenient means of correcting the inequality of valve opening due to the connecting-rod angularity, the details of which will be explained farther on.

#### AIDS TO THE STUDY OF VALVE-MOTION.

An engineer or machinist who wishes to study out this peculiarity of connecting-rod angularity, will find that the use of a tram or long dividers will help him to comprehend it better than any letter-type description. All through the study of the valve-motion, there are numerous difficult problems encountered. The use of a good model will be found an invaluable aid to the study of the valve-motion, and every division of engineers or firemen should make a combined effort to furnish their meeting-room with a model of a locomotive valve-motion. In no way can the spare time of the men connected with locomotive running be better employed than in the wide range for study presented by a well-devised model. Great aid can be obtained in the study of the valve-motion from good books devoted to the subject, and they will impart more information than can be obtained by mere contact with the locomotive. The valve and its movements are surrounded with so many complicated influences, that an intelligent man may work for years about a locomotive, doing valve setting occasionally, and other gang-boss work, yet, unless he

studies the valve-motion by the aid of the drawing-board, or by models, which admit of changing sizes and dimensions, he may know less about the cause of certain movements than the bright lad who has been a couple of years in the drawing-office. The man who thinks he can study the valve-motion, and understand its philosophy, by merely running the engine, deceives himself. The engineer who never looks at a book or a paper in search of information about his engine, knows very little about anything not visible to the eye. Yet many men of this stamp, by looking wise, and by exercising a judicious use of silence, pass among their fellows as remarkably profound. But let a fireman, in quest of locomotive knowledge, put a question to such a man, and he is immediately silenced with a "You ought to know better" answer.

Where the use of a model cannot be obtained, any one beginning the study of the valve-motion can assist himself by making a cross-section of the valve and its seat, similar to those published, on a strip of thin wood or thick paper. By slipping the valve on the seat, its position at different parts of the stroke can be comprehended more clearly than by a mere description. With a pair of dividers to represent the motion of the eccentric, and strips of wood to act as eccentric, and valve rod and rocker, and some tacks to fasten them together, a helpful model can be improvised on a table or board. By the time a student gets a rig of this kind going, he will see his way to contrive other methods of self-help.

## EVENTS OF THE PISTON STROKE.

By the aid of Fig. 10, we will trace the relative movements of the crank and eccentric connections. For the sake of simplicity, the eccentric is represented as connecting directly with the rocker-arm.

The crank-pin being at the point *A*, or the forward center, the piston must be in the front of the cylinder, or at the beginning of the backward stroke. Owing to the angular advance already referred to, the eccentric center is at *F*; and, being a certain distance ahead of the middle position, it has pushed the lower arm of the rocker from *a* to *b*, drawing back the top arm, which, in its turn, has moved the valve so that it is just beginning to admit steam at the forward port, *i*. As the crank-pin goes round, the eccentric follows it, opening the steam-port wider till the eccentric reaches the point of its travel nearest *A*, the limit of the throw. When the eccentric is at this point of its throw, the valve must be at the outside of its travel; and therefore the steam-port is wide open. By this time the crank-pin is getting close up towards the quarter. After passing this point, the forward eccentric begins to draw the bottom rocker-pin towards the axle, and to push the valve ahead, this being the point where the valve changes its direction of motion, just as the piston returns when the crank-pin passes the center. When *F* reaches the point *B*, the valve is in the same position it occupied at the beginning of the stroke; but, as it is traveling in the opposite direction, a very small movement more closes the port, cutting off steam.



When this happens, the crank-pin has reached the point  $x$ . When  $F$  gets to  $g$ , it is on the central point of its throw; so the valve must then be on the middle point of its travel, with the exhaust cavity just covering the outside edges of the bridges, the forward edge being ready to put the steam-port,  $i$ , in communication with the exhaust cavity. This releases the steam from the forward end of the cylinder; and at the same moment the inside edge of the valve covers the back port,  $k$ , causing the piston-head to compress any steam left in the back part of the cylinder. When the piston reaches the beginning of the forward stroke, the eccentric  $F$  has got to the point  $f$ , and the valve is beginning to admit steam for the return stroke, the events of which are similar to those described.

In actual practice, the steam distribution is a little different from the manner that has been followed; for the link-motion provides the means of equalizing the cut-off, making it uniform for both strokes. This changes the events of the strokes a little; but the student who engraves in his mind the movements as they are represented in the diagram, will not be far astray.

#### WHAT HAPPENS INSIDE THE CYLINDERS WHEN AN ENGINE IS REVERSED.

Many men who have a fair understanding of the action of steam in an engine's cylinders during ordinary working, have no idea of the operations performed in the cylinders when a locomotive is running in reverse motion. All men who have had anything to do with

train service know, that, when an engine is reversed, the action works to stop the train, even if the locomotive should have no steam on the boiler; but just in what way this result comes round they can not clearly perceive. In hopes of throwing light upon this subject for those who have not studied it out, we will follow the events of a stroke in reversed motion, as we did in the ordinary working.

#### EVENTS OF THE STROKE IN REVERSED MOTION.

Supposing an engine to be running ahead, and the necessity arises for stopping suddenly, and the reverse-lever is pulled into the back notch. When the crank-pin is on the forward center, and therefore the piston at the forward end of the cylinder, about to begin its backward stroke, the valve has the forward port open a distance equal to the amount of lead, as in Fig. 10. But, as the back-up eccentric has control of the valve, the latter is being pushed forward; and it closes the forward port just as the piston begins to move back. This shuts off all communication with the forward end of the cylinder; and the receding piston creates a vacuum behind it, just as a pump-plunger does under similar circumstances. At this time the back end of the cylinder is open to the exhaust, and the piston pushes out the air freely to the atmosphere. By the time the piston travels about two inches, the valve gets to its middle position; and, immediately after passing that point, it opens the forward end of the cylinder to the exhaust, and closes the back port. When this event happens, the vacuum in the forward

end of the cylinder gets filled with hot gases, that rush in from the smoke-box; and the receding piston keeps drawing air into the cylinder in this way during the remainder of the stroke, and air from that quarter seldom gets in without bringing a sprinkling of cinders. The back steam-port is closed only during about two inches of the stroke, while the lap of the valve is traveling over it. About the time the piston reaches four inches of its travel, the back steam-port is open to the steam-chest, and the piston forces the air through the steam-pipes into the boiler during the remainder of the stroke. The forward stroke is merely a repetition of the backward stroke described.

When it is necessary to reverse a locomotive, it is a better plan to hook the lever clear back than to have it a notch or two past the center, as some men persist in doing, under the mistaken belief that they are in some way saving their engine from harsh usage. When the link is reversed full, the cylinders are merely turned into air-pumps. When the links are put near the center, the travel of the valve is reduced; and the periods when the piston is creating a vacuum in one end of the cylinder, and compressing the air in the other, are prolonged. The result is, that, when the exhaust is opened in the first case, the gases rush in violently from the smoke-box, carrying a heavy load of cinders: in the other case, the piston compresses the air in the cylinder so high that it jerks the valve away from its seat in trying to find outlet. This causes the clattering noise in the steam-chest, so well known in cases

where engines are run without steam while the reverse-lever is near the center.

A locomotive with the piston-packing in bad order will not hold well running in reverse-motion. Some kinds of piston-packing do not seem to act properly when the engine is reversed, especially at low speed. Where a valve has much inside lap, there will be a vacuum in one end of the cylinder, and compressed air in the other end. With piston-packing that requires pressure to expand it, the void at one end of the cylinder may neutralize the pressure at the other by drawing the air through the piston. This would be most liable to happen where the lever was kept near the center.

#### PURPOSE OF RELIEF-VALVE ON DRY PIPE.

Should the throttle-valve close so tight that the compressed air from the cylinders cannot pass into the boiler, there is danger of bursting the steam-chest or some part of the steam-pipes. The compressed air will lift most of the throttle-valves far enough to prevent any great danger from this source. In some engines a relief-valve is secured in the dry pipe, which provides a passage for this compressed air. When the cylinder-cocks of an engine are opened when the motion is reversed, they form an outlet to the compressed air, and also admit air to the sucking end without letting the piston draw air so freely through the nozzles. Many cylinder-cocks are now made so

that they will open automatically to permit the piston to draw air through them. The reversed engine will stop nearly as well with the cylinder-cocks opened as when they are closed, and it is much more easily handled with the cocks opened. Where the cocks are kept closed, the rush of hot air from the smoke-box laps every trace of oil from the valve-seat, and a heavy pressure—frequently above that of the boiler—is present in the steam-chest. When the engine stops under these circumstances, its tendency is to fly back; and an engineer has some difficulty in controlling it with the reverse-lever till a few turns empty the chest and pipes.

#### USING REVERSE-MOTION AS A BRAKE.

Numerous attempts have been made to utilize the reversed engine as a brake for stopping the train, and even by this means to save some of the power lost in stopping. Chatelier, a French engineer, experimented for many years on this mechanical problem. He injected a jet of water into the exhaust-pipe, which supplied low-tension steam to the cylinder, instead of hot gas or air coming through the smoke-box. This was pumped back into the boiler on the return stroke. Thus the act of stopping a train was used to compress a quantity of steam, converting the work of stopping into heat, which was forced into the boiler and retained to aid in getting the train into speed again. Modifications of this idea produce the car-starters that pass so frequently through our Patent Office.

As a means of conserving mechanical energy, the Chatelier brake was not a success; but, in the absence of better power brakes, it met with some applications in Europe. Some of our mountain railroads use it, under the name of the water-brake, as an auxiliary to the Westinghouse automatic brake.

## CHAPTER XVI.

### THE SHIFTING LINK.

#### EARLY REVERSING MOTIONS.

IN the engineering practice of the world, before the locomotive and marine engines came into use, there was no need for devices to make engines rotate in more than one direction. When the need for a reversible engine first arose, it was met by very crude appliances. Locomotives were kept at work, earning money for their owners, which were reversed by the man in charge stopping the engine, and by means of a wrench changing the position of the eccentric by hand. A decided improvement on the wrench was the movable eccentric, which was held in forward or back gear by stops; the operation of reversing being done by a treadle or other attachment located near the engineer's position. A serious objection to this form of reversing gear was, that the abrasion of work enlarged the slot ends, and wore out the stops, leading to inaccuracy and frequent breakage. A somewhat better form of reversing motion was a fixed eccentric, with the means at the end of the eccentric-rod for engaging with the top or bottom of a rocker-shaft, which operated the valve-stem. This was the form of reversing motion

used on the early Baldwin engines. Numerous other appliances, more or less defective, were experimented with before the double fixed eccentrics were introduced. Till the link was applied to valve-motion, the double eccentrics—an American invention—were the most important improvement that had been made on the locomotive valve-motion since the incipency of the engine. The V-hook, in connection with the double eccentrics, made a fair reversing motion in comparison to anything that had preceded it. The objection to the hook was, that, when the necessity arose for reversing the engine while in motion, much difficulty was experienced in getting the hook to catch the pin. As a simple, prompt, and certain reversing motion, the link was readily acknowledged to be far superior to anything that had previously been tried.

#### INVENTION OF THE LINK.

There is no doubt but the link was first applied to a steam engine by William T. James of New York, a most ingenious mechanic, who also invented the double eccentrics. James experimented a great deal about the period from 1830 to 1840, with steam carriages for common roads; and it was in this connection that he invented the link. His work having proved a commercial failure, the improvements on the valve-motion were not recognized at the time; although the probability is that Long, who started the Norris Locomotive Works of Philadelphia, and brought out the double eccentrics upon the locomotives built there.



was indebted to James for the idea of a separate eccentric for each direction of engine movement.

The credit of inventing the ordinary shifting link is due to William Howe of Newcastle, England. This inventor was a pattern-maker in the works of Robert Stephenson & Co., and he invented the link in 1842 in practically its present form. The idea of Howe was to get out an improved reversing motion; and he made a pencil sketch of the link, to explain his views to his employers. The superintendent of the works was favorably disposed to the invention, and ordered Howe to make a pattern of the motion, which was done; and this was submitted to Stephenson, who approved of the link, and directed that one should be tried on a locomotive. Although Stephenson gave Howe the means of applying his invention, he does not seem to have perceived its actual value, for the link was not patented; and Stephenson never failed to patent any device which he thought worth protecting.

The link-motion was applied to a locomotive constructed for the Midland Railway Company, and proved a success from the day it was put on. Seeing how satisfactorily the invention worked, Robert Stephenson paid Howe twenty guineas (one hundred and five dollars) for the device, and adopted the link as the valve-gear for his locomotives. This is how the shifting link comes to be called the "Stephenson link" and the credit for this invention was not extravagantly paid for.

The capability which the link possesses of varying

the steam admission and release, did not appear to be understood by the inventor; nor was the mechanical world aware, for some time after the link was brought into use, that it could be employed to adjust the inequality of steam distribution, due to the angularity of the connecting rod.

#### CONSTRUCTION OF THE SHIFTING LINK.

As usually constructed for American locomotives, the link is a slotted block curved to the arc of a circle, with a radius about equal to the distance between the center of the driving-axle and the center of the rocker-pin. The general plan of the link-motion is shown in Fig. 12. Fitted to slide in the link-slot is the block which encircles the rocker-pin. The eccentric-rods are pinned to the back of the link; the forward eccentric-rod connecting with the top, and the back-up eccentric-rod with the bottom, of the link. Bolted to the side and near the middle of the link is the saddle, which holds the stud to which the hanger is attached; this, in its turn, connecting with the lifting arm, which is operated by the reversing rod that enables the engineer to place the link in any desired position.

#### ACTION OF THE LINK.

Regarded in its simplest form, the action of the link in full gear is the same upon the valve movement as a single eccentric. When the motion is working, as in the figure, with the eccentric-rod pin in line with the rocker-pin, it will be perceived that the movement can not differ much from what it would be were the eccen-

tric-rod attached to the rocker. Here the forward eccentric appears as controlling the movement of the

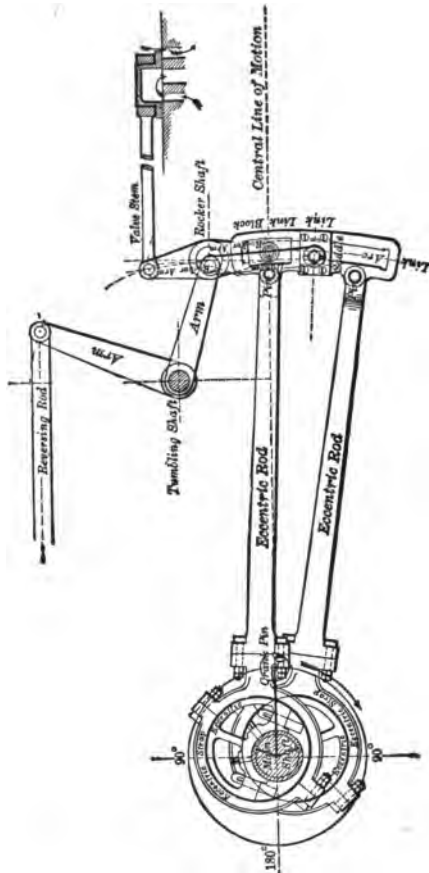

FIG. 12.

valve. Putting the link in back motion brings the end of the backing eccentric-rod opposite the rocker-pin,

the effect being that the back-up eccentric then operates the valve. When the link-block is shifted toward the center of the link, the horizontal travel of the rocker-pin is decreased; consequently, the travel of the valve is reduced; for, with ordinary engines, the travel of the valve in full gear equals the throw of the eccentrics, the top and bottom rocker-arm being of the same length. The motion transmitted from the eccentrics, and their means of connection with the link, make the latter swing as if it were pivoted on a center which had a horizontal movement equal to the lap and lead of the valve. The extremities of the link, or rather the points opposite the eccentric-rods, swing a distance equal to the full throw of the eccentric. The variation of valve-travel that can be effected by the link, is from that of the eccentric throw in full gear down to a distance in mid gear which agrees with the extent of lap and lead. The method of obtaining these various degrees of travel is by moving the link so that the block which encircles the rocker-pin shall approach the middle of the link.

When an engine is run with the lever in the center notch, the supply of steam is admitted by the lead-opening alone. In full gear the eccentric, whose rod-end is in line with the rocker-pin, exerts almost exclusive control over the valve movement; but, as the link-block gets hooked towards the center, it comes to some extent under the influence of both eccentrics.

A thoughtful examination of Fig. 12 will throw light on the reason why the proper position of a slipped eccentric can be determined by the other eccentric

when the engine is on the center. In the cut, the crank-pin is represented on the forward center; and in that position the eccentric centers are both an equal distance in advance of the main shaft center. It will be evident now that the valve must occupy practically the same position for forward or back gear, as each of the eccentric-rods reaches the same distance forward. Putting the motion in back gear would bring the back-up eccentric-rod pin to the position now occupied by the pin belonging to the forward eccentric-rod.

#### VALVE-MOTION OF A FAST PASSENGER LOCOMOTIVE.

Reducing the travel of the valve by drawing the reverse-lever towards the centre of the quadrant, and consequently the link-block towards the middle of the link-slot, not only hastens the steam cut-off, but it accelerates in a like degree every other event of steam distribution throughout the stroke. To explain this point, let us take the motion of a well-designed engine in actual service, which has done good economical work on fast train running. The valve-travel is five inches, lap one inch, no inside lap, lead in full gear  $\frac{1}{16}$  inch, point of suspension  $\frac{9}{16}$  inch back of center of link.

#### EFFECT OF CHANGING VALVE-TRAVEL.

When this engine is working in full gear, the steam will be freely admitted behind the piston till about eighteen inches of the stroke, when cut-off takes place; and the release or exhaust opening will begin

at about twenty-two inches of the stroke, giving four inches for expansion of steam. Now, if the links of this engine are hooked up so that the cut-off takes place at six inches of the stroke, the steam will be released at sixteen inches of the stroke; and at that point compression will begin at the other end of the cylinder.

#### WEAK POINTS OF THE LINK-MOTION.

This attribute which the link-motion possesses, of accelerating the release and compression along with the cut-off, is detrimental to the economical operating of locomotives that run slow. High-speed engines need the pre-release to give time for the escape of the steam before the beginning of the return stroke; and the compression is economically utilized in receiving the heavy blow from the fast-moving, reciprocating parts, whose direction of motion has to be suddenly changed at the end of each stroke, and in helping to raise the pressure promptly in the cylinder at the beginning of the stroke. A locomotive, on the other hand, that does most of its work with a low-piston speed, would not suffer from back pressure if the steam were permitted to follow the piston close to the end of the stroke; and a very short period of compression would suffice. If the engine, whose motion we have been considering, instead of releasing at sixteen inches, could allow the steam to follow the piston to twenty-two inches of the stroke, after cutting off at six inches, a very substantial gain of power would ensue. And this would be well supplemented by avoid-

ing loss of power, did compression not begin till within two inches of the return stroke.

WHY DECREASING THE VALVE-TRAVEL INCREASES  
THE PERIOD OF EXPANSION.

Increase of expansion follows reduced valve-travel, from a similar cause to that which produces expansion when lap is added to the edge of a slide-valve. When the valve is made with the face merely long enough to cover the steam-ports, there can be no expansion of the steam; for, so soon as the valve ceases to admit steam, it opens the steam-port to the exhaust. When lap is added, however, the steam is inclosed in the cylinder, without egress for the time that it takes the lap to travel over the steam-port. An arrangement of motion which will make the valve travel quickly over the port, has a tendency to shorten the period for expansion; while making the valve travel slowly over the port, has the opposite effect, and protracts expansion. A valve with, say, five inches travel, has a comparatively long journey to make during the stroke of the piston; and the lap-edges will pass quickly over the steam-ports,—much more quickly than they will when the travel is reduced to three inches. In a case of this kind, there is more than the mere reduction of travel to be considered. Suppose the valve has one inch lap at each end. When it stands on the middle of the seat, it has a reciprocating motion of two and one-half inches at each side of that point to make. At the beginning of the stroke, it has been drawn aside one inch (we will ignore the lead), but still has one and

one-half inch to travel before it begins to return. On the other hand, when the travel is reduced to three inches, the valve has only one and one-half inch to travel away from the center; and, one inch being moved to draw the lap over the port, there only remains one-half inch for the valve to move before it must begin returning. This entails an early cut-off; for the valve must pass over the ports with its slow motion, and be ready to open the port on the other end, before the return stroke. Thus a travel of five inches draws the outside edge of the valve one and one-half inch away from the outside of the steam-ports, three inches travel only draws it one-half inch away, and a greater reduction of travel decreases the opening in like proportion.

#### INFLUENCE OF ECCENTRIC THROW ON THE VALVE.

As reducing the travel of the valve diminishes the port opening, a point is reached in cutting off early in the stroke where the port opening is hardly any more than the port opening due to the lead. This is what makes long-steam-ports essential for a successful high-speed locomotive. The best-designed engines give an exceedingly limited port opening at short cut-offs, and badly planned motion sometimes seriously detracts from the efficiency of the engine, by curtailing the opening at the point where a very brief time is given for the admission of steam. The magnitude of the eccentric throw exerts a direct influence on the port opening when cutting off early. A long throw tends to increase the opening, while a short throw reduces



it. The long-throw eccentric will draw the valve farther away from the edge of the steam-port, when admitting steam for the same point of cut-off, than a short-throw eccentric will move its valve. For an ordinary  $17 \times 24$  inch locomotive, the throw of eccentric should not be less than five inches, unless the engine is intended entirely for slow running. There are many engines running with eccentric throw less than five inches, but they are invariably slow unless the valve lap is very short. With an ordinary lap, an engine having an eccentric throw of  $4\frac{1}{2}$  inches needs so much angular advance to overcome the lap, and provide lead, that the rectilinear motion of the eccentric is very meagre at the beginning of the stroke. That is, the center of the eccentric is traveling downward in its circular path, which gives little motion to the valve, just as the crank gives decreased motion to the cross-head when near the centers.

#### HARMONY OF WORKING-PARTS.

Hitherto we have regarded the link as merely performing the functions of transmitting the motion of the eccentrics to the valves, with the additional capability of reducing the travel at the will of the engineer. Otherwise, the motion of the link is intensely complex; and its movements are susceptible to a multitude of influences, which improve or disturb its action on the valve. A good valve-motion is planned according to certain dimensions of all the working-parts; and any change in their arrangement will almost invariably entail irregularities upon the link's movement,

which will radically affect the distribution of steam. A link-motion schemed for an eccentric throw of  $4\frac{1}{2}$  inches will not work properly if the throw be increased to five inches; a link with a radius of 57 inches can not be changed with impunity for one of 60 inches. Any change in the position of the tumbling-shaft or rocker-arms distorts the whole motion, and any alteration in the length of the rods or hangers has a similar effect. That the link may perform its functions properly, all its connections must remain in harmony.

#### ADJUSTMENT OF LINK.

A very important feature of the link is its property of adjustability, which serves to neutralize the distorting effect of the connecting-rod's angularity. As has already been explained, the angularity of the main rod tends to delay the cut-off during the backward stroke, while it is accelerated in the forward stroke. With the ordinary length of connections, this irregularity would seriously affect the working of the engine. But it is almost entirely overcome by the link, which can be suspended in a way that will produce equality for the period of admission and point of cut-off for both strokes in one gear. Perfect equalization of admission and cut-off for both gears has been found impossible with the link-motion; and designers are generally satisfied to adjust the forward motion, and permit the back motion to remain untrue. The point about the link which exercises the most potent influence on adjusting the cut-off, is the position of the saddle, or of its stud for connecting the hanger. This stud is called

the point of suspension. Raising the saddle away from the center of the link will effect adjustment of steam admission; but in locomotive practice the saddle is nearly always located in the middle of the link, there being practical objections against raising it. Equalization of steam distribution is produced by placing the hanger-stud or point of suspension some distance back of the center line of the link-slot, the distance varying from 0 to  $\frac{7}{8}$  inch.

Moving the hanger-stud affects the link's movement in a way that is equivalent to temporarily lengthening the eccentric-rod during a portion of the piston-stroke. The length of the tumbling-shaft arms, the length of hanger, the location of the rockers and tumbling-shaft, the radius of link, and length of rods, all exercise influence on the accurate adjustment of the valve-motion.

#### SLIP OF THE LINK.

In equalizing the valve-motion, and overcoming the discrepancy of steam admission, due to the angularity of the connecting-rod by moving the link-hanger stud away from the center of the slot, a new distortion is introduced. The link-block being securely fastened to the bottom of the rocker-pin, moves in the fixed arc traversed by that pin, which is nearly horizontal. The action of the eccentric-rods on the link, on the other hand, forces the latter to move with a sort of vertical motion at certain parts of the stroke, making it slip on the block. Moving the hanger-stud back tends to increase this slip, which will become excess-

ive enough to seriously impair the efficiency of the motion if not kept within bounds by the designer. Where the slip is very great, the motion will not be serviceable, a consideration which can never be overlooked; for the block will wear rapidly, producing lost motion, a very undesirable defect about any part of a link-gear. With the long rods which prevail in locomotive practice, designers have no difficulty in keeping the slip within practical bounds; but with marine engines it is sometimes necessary to sacrifice equality of steam admission to the reduction of the slip. The greatest amount of slip is in full gear, and it diminishes as the link-block is moved towards the center.

Placing the eccentric-rod pins back of the link-arc, as is almost universally done in this country, has a tendency to make the link slip on the block; and care has to be taken not to locate these pins farther back than is actually necessary for other requirements of the link-motion's adjustment. Auchincloss, who is a recognized authority for designing of link-motion, gives four varieties of alterations capable of reducing the slip when it is found too great for practicable motion. His resorts are, either to increase the angular advance, reduce the travel, increase the length of link, or shorten the eccentric-rods. One or a combination of these methods may be adopted, as the designer finds most convenient.

## RADIUS OF LINK.

Among the constructing engineers who plan link motion, there is considerable diversity of opinion about what radius of link helps to produce the best valve-motion. The distance between the center of axle and center of lower rocker-pin may be accepted as approximately correct, although some designers slightly increase beyond these points. On the other hand, the locomotives sent out from a leading building establishment have the radius of link drawn  $\frac{1}{4}$  inch per foot short of the distance between the axle and rocker; and the claim has been made, that the arrangement produces an excellent motion.

A committee of the American Master Mechanics' Association have placed themselves on record on this subject by asserting that the distance between the centers of axle and rocker-pin is the proper radius for the link. That same committee recommended that the link-motion should be planned to give as long a link-radius as possible, subject to the first-mentioned conditions.

It must be noted that the middle of the link-slot is the radius arc. I knew of a case where the links for an altered locomotive were finished out of the true radius through the edge of the slot being taken as the radius-curve.

## INCREASE OF LEAD.

Most of the men who are at all familiar with the valve-motion are aware of the fact that, with the shift-

ing link, the lead increases as the link is notched towards the center. Where the valve has  $\frac{1}{8}$ -inch lead in full gear, it is no unusual thing to find it increase to  $\frac{1}{4}$ -inch lead opening at mid gear. The phenomenon is better known than its cause is understood.

The relative positions of link and eccentric centers of an engine, when the crank is on the forward center, are shown in Fig. 13; the link being represented with

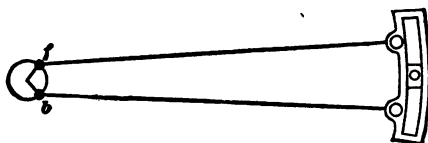

FIG. 13.

the block in the center, which represents mid gear. It will be observed that the centers of the eccentrics *f* and *b*, from which the rods receive direct influence, are both some distance ahead of the center of the axle, the one above, the other below. The eccentric-straps to which the rods are connected sweep round the eccentric circles, and are controlled thereby. When the link is moved up or down, each eccentric-rod pin, where it attaches to the link, describes the arc of a circle with a radius drawn from its own eccentric. If both rods were worked with a radius from the axle-center, the link could be raised and lowered when the engine stands on the dead center without moving the rocker-pin at all; but, under the existing arrangement, the link is influenced directly by one or other of the eccentrics, whatever position in the link.

the block may stand. When the engine is standing on the forward center, with the link in mid gear, as shown in Fig. 13, it will be readily perceived that the block stands at its farthest point away from the axle; for the rods are so placed to reach their greatest horizontal distance ahead, and consequently in this position the lead opening is greatest. If the link be now lowered, the backing eccentric-rod will immediately begin to pull the link back: and, as the pin of the forward eccentric-rod approaches the central line of motion, it will also keep drawing the link back; so that, by the time the link is in full gear, the lead opening will be considerably reduced.

When the engine stands on the back dead center, as shown in Fig. 14, the eccentric centers will be on

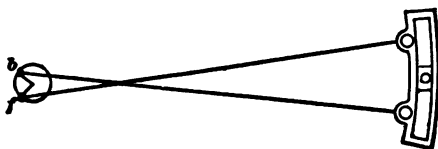

FIG. 14.

the other side of the axle, and the eccentric-rods will be crossed. While in mid gear, the link-block is drawn closer to the axle than it would be in any other position of the link; and consequently the lead opening is greatest. If the link be now lowered, the forward eccentric-rod will approach its horizontal position, and consequently reaches farther on the central line of motion, so it will push the link-block away from the axle, thereby decreasing the lead. Pulling the link into back gear has a similar effect.

The tendency of a link-motion to increase the lead towards the center is made greater by shortening the eccentric-rods. Increasing the throw of eccentric inclines to accelerate the lead towards the center, since it throws the eccentric centers farther apart. For slow running, hard-pulling locomotives, where increase of lead is a disadvantage, the tendency to increase the lead is sometimes restrained in forward gear by reducing the angular advance of the backing eccentric. This expedient is, however, not necessary where proper care and intelligence have been bestowed in the original design of the motion.

In studying this part of the valve-motion, a young machinist or engineer will obtain valuable assistance by cutting a link template out of a piece of paste-board, and using strips of wood as eccentric-rods. With these he can test on a drawing-board or table the various positions of the link, and note, in a way that is easily understood, the effect of changing the link into different positions.



## CHAPTER XVII.

### SETTING THE VALVES.

#### THE MEN WHO LEARN VALVE-SETTING.

MOST of intelligent machinists engaged on engine-work make it an object of ambition to learn to set valves; and the operation is mastered as soon as the opportunity offers. It has been a practice in numerous shops for those who have the work of valve-setting to do, to invest the operation with fictitious mystery, to patiently disseminate the belief that valve-setting is an exceedingly difficult matter. Cases sometimes arise where the squaring of an engine's valves is really an arduous task, requiring intimate familiarity with delicate methods of adjustment; but valve-setting, as it is usually practiced in building establishments, in repairing-shops, and in round-houses, is merely a matter of plain measurement.

A man may be a first-class engineer without knowing how to set valves, and familiar acquaintance with the operation will not increase his ability in managing his engine when merely getting a train over the road on time is the consideration; but the method of valve-setting is so closely associated with an intelligent ap-

preciation of the valve-motion's philosophy, that most of engineers who take an extended interest in their business, wish to acquire the knowledge of how the valves are set.

#### BEST WAY TO LEARN VALVE-SETTING.

The best way to learn valve-setting is by taking part in the work. Whatever can be said in books on a subject of this kind, provides but an indifferent substitute for going through the actual operations. But a man's ambition to learn may exceed his opportunities; so, for those who cannot get a gang boss to direct them into the art of valve-setting, this description will be made as plain as possible.

When an engine's valve-motion is designed, the sizes of the different parts are arranged; and, if this business is done by a competent engineer, there will only be trifling changes necessary in valve-setting.

#### PRELIMINARY OPERATIONS.

Let us suppose the engine to be an ordinary eight-wheel locomotive, with cylinders  $17 \times 24$  inches. Let us assume that the top and bottom rocker-arms are straight, of equal length, and that the eccentric-rods are connected to the link so as to be opposite the block in full gear. This will make the extreme travel of valve equal the eccentric's throw. We will now look round to see that everything connected with the motion is ready for valve-setting.

First, it is necessary to see that the wedges are properly set up to hold the driving-boxes in about the

same position they will occupy when the engine is at work.

#### CONNECTING ECCENTRIC-RODS TO LINK.

In looking over the motion, it is well to note that the eccentric-rods are properly connected,—the forward eccentric-rod with the top, the backward eccentric-rod with the bottom, of the link. When the crank-pin is on the forward center, the eccentrics will occupy the position they appear in, in Fig. 15, where the rods

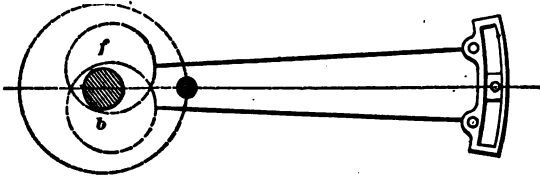

FIG. 15.

are open, and nearly horizontal. The full parts of both eccentrics are advanced towards the crank-pin, so that the centers of the eccentrics are advanced from a perpendicular line drawn through center of axle, a horizontal distance equal to the lap and lead. When the crank-pin is on the back center, the eccentric

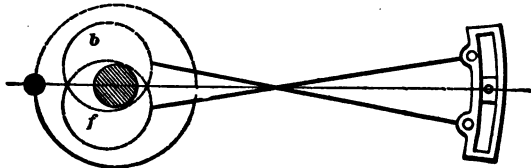

FIG. 16.

centers will be behind the axle, and the rods will be crossed as they are seen in Fig. 16. The reason why

the rods must be crossed when the crank is in this position, is, that the forward eccentric center is below the axle, and the backward eccentric center is above. As the forward eccentric-rod maintains its connection with the top of the link, and the backward eccentric-rod is at the opposite end, crossing of the rods is inevitable. This fact is worth imprinting on the memory, for I have known of several cases where men got the rods up wrong by putting them open when the engine stood with the crank on the back center.

#### MARKING THE VALVE-STEM.

In ordinary practice, valves are set with the steam-chest cover down, and the position of the valve on the seat is identified by marks on the valve-stem. Before the cover is put down, the valve is placed as in Fig. 17, just beginning to open the forward steam-port; a

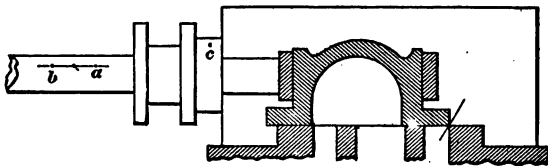

FIG. 17.

thin piece of tin being generally used to gauge the opening. When the valve stands in this position, a tram is extended from a center punch-mark *c*, on the stuffing-box, straight along the valve-stem as far as it will reach; and the point, here located at *a*, is marked. The valve is then moved forward till it begins to uncover the back port, when another measurement is

made with the tram, which locates the point *b* on the valve-stem. Whatever position the valve may stand on, it may now be identified by the tram. When the tram cuts the space half-way between *a* and *b*, the valve stands in the middle of the seat.

Some machinists do not believe in tramping from the stuffing-box, as the point is liable to be moved in tightening down the steam-chest cover. These generally measure from a point on the cylinder casting, but that practice has its drawbacks.

#### LENGTH OF THE VALVE-ROD.

To prove the correct length of the valve-rod, the rocker-arm is set at right angles to the valve-seat, which is its middle position. The valve must now stand on the middle of the seat, which will be indicated by the tram point reaching the dividing point between *a* and *b*. Should the valve not be right when the rocker is in its middle position, the rod must be altered to put it right.

#### ACCURACY ESSENTIAL IN LOCATING THE DEAD-CENTER POINTS.

Before proceeding to set the valves, a machinist can not be too careful in locating the exact dead centers. Some men conclude, because there is little motion to the cross-head close to the end of the stroke, that a slight movement of the wheel to one side or the other is of little consequence, and makes no perceptible difference in the relative positions of piston and valve. This is a serious mistake; for, although the piston is

moving slowly, the eccentric is proceeding at its ordinary speed, and the valve is moving fast. The loose, quick methods of finding dead-centers followed occasionally are not conducive to exactness, and nothing but accuracy is permissible in valve-setting.

#### FINDING THE DEAD-CENTERS.

The best way of finding the true center is by moving the cross-head a measured distance round its extreme travel, recording the extent of movement on the driving-wheel tire, whose motion is uniform; then bisecting the distance between the marks on the tire, when the dividing-line will indicate the true center.

Thus: Turn the wheels forward till the cross-head reaches within one-half inch of its extreme travel, as shown in Fig. 18. From a point *a* on the guide-block

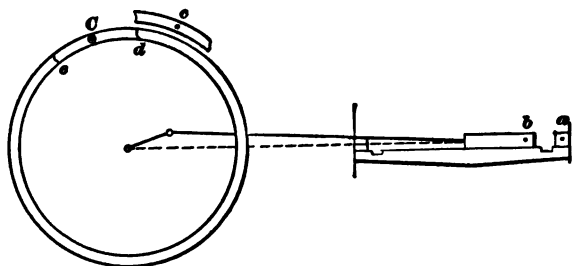

FIG. 18.

extend a tram on the cross-head, and mark the extreme point reached *b*. Put a center-punch mark *c* on the wheel-cover, or other convenient fixed point, and from it extend a tram on the edge of the tire, and scratch an arc *d*. Now, with tram in hand, watch the

cross-head, and have the wheels moved forward slowly. When the cross-head passes the center, and moves back till the tram extending from  $a$  will reach the point  $b$ , stop the motion. Again tram from the wheel-cover point, and describe a second arc on the tire, which will be at  $e$ , now moved to the position which  $d$  occupied when the previous measurement was taken. With a pair of dividers bisect the distance between  $d$  and  $e$ . Mark the dividing-point  $C$  with a center-punch, and put a chalk-ring round it. When the wheel stands so that the tram will extend from  $c$  to  $C$ , the engine will be on the forward dead-center.

All the other centers must be found by a similar process.

#### TURNING WHEELS AND MOVING ECCENTRICS.

When a measurement is going to be made for fore gear, the wheels must be turned forward; and, when it is for the back gear, they must be turned backward. Enough movement of the wheel must be given to take up the lost motion every time the direction of movement is changed. In moving an eccentric, it should also be turned far enough in the opposite direction to take up the lost motion.

#### SETTING BY THE LEAD-OPENING.

Put the reverse-lever in the full forward notch, and place the engine on the forward center. If the lead-opening in full gear is to be  $\frac{1}{8}$  inch, advance the forward eccentric till the point  $a$  (Fig. 17) on the valve-

stem is that distance away from the tram-point. Throw the reverse-lever into the full backward notch, turn the wheels forward enough to take up the lost motion, then turn them back to the forward center. Move the backward eccentric (if it needs moving) till the tram, extended on the valve-stem, strikes the same point that it reached for the forward motion. It will be noted here that the valve occupies the same position for fore and back gear when the engine is on the center. Put the reverse-lever in the forward notch again, and turn the wheels ahead till the back center point is reached. Now tram the valve-stem again, and, if the lead-opening be the same for both gears as it was on the forward center, that part of the setting is right. It is a good plan to go over the points a second time to prove their correctness. But it is not likely that the lead-opening at the back end will be right on the first trial. Instead of having the correct lead, the valve will probably lap over the port, being what workmen call "blind," or it will have too much lead. Let us assume that our valve is  $\frac{1}{16}$  inch blind. This indicates that the eccentric-rod is too long. We shorten the rod till the valve is at the opening-point, and, on turning the engine to the forward center again, we will find that the valve there has lost its lead. But our change has adjusted the valve movement, so that on each center the valve is just beginning to open the steam-port. Advancing the eccentric to give one end  $\frac{1}{16}$  inch lead will now have the same effect upon the other end; and, assuming that the back motion has been subjected to similar treatment with a like result,



the lead-opening on that side is right. This process must now be repeated with the other side of the engine.

#### ASCERTAINING THE POINT OF CUT-OFF.

The lead openings being properly arranged, we will proceed to examine how the valves cut off the steam; for it is important that about the same supply of steam should be furnished to each cylinder and to each end of the cylinders. The angularity of the connecting-rod tends to give a greater supply of steam to the forward than to the back end of the cylinder; but this inequality is, as has already been explained, usually rectified by locating the hanger-stud a certain distance back of the link arc.

To prove the cut-off, we will try the full gear first. Put the reverse-lever in the full forward notch, starting from the forward center, and turn the wheels ahead. The motion of our engine has been designed so that the cut-off in full gear shall happen at 18 inches of the stroke. With tram in hand, watch the movement of the valve as indicated by the stem marks. As the piston moves away from the forward end of the cylinder, the valve will keep opening till nearly half stroke is reached, when it will begin to return, slowly at first, but with increasing velocity as the point of cut-off is reached. When the point *a*, Fig. 17, gets so that it will be reached by the tram extended from *c*, the motion must be stopped; as that indicates the point of cut-off. Now measure on the guide how far the cross-head has traveled from the beginning of the stroke, and mark it down with chalk.

Then turn the wheels in the same direction past the back center, and obtain the cut-off for the forward stroke in the same manner. The cut-off for the other cylinder will be found in precisely the method described.

In addition to trying the cut-off in full gear, it is usually tested at half stroke and at 6 inches, or with the reverse-lever in the notches nearest to these points. Some men begin at the first notch, and follow the point of cut-off in every notch till the center is reached, and do the same for back gear.

#### ADJUSTMENT OF CUT-OFF.

From various causes, it often happens that the cut-off is unequal in the two strokes, or one cylinder may be getting more steam than the other. Suppose, that, on one side of the engine, the valve is cutting off at  $18\frac{1}{2}$  inches in forward gear, while at the other side it is cutting off at  $17\frac{1}{2}$  inches of the stroke. The most ready way to adjust that inequality is by shortening one link-hanger and lengthening the other till a mean is struck. Where the discrepancy is smaller, it is adjusted by lengthening the hanger at the short side.

A harder inequality to adjust is where the valve cuts off earlier for one end of the cylinder than for the other. In new work this is readily overcome by the saddle-stud, but such a change is seldom admissible in old work. When the points of cut-off have been noted down, it will frequently happen, that, instead of both ends cutting off at 18 inches, one end will show the cut at 17 inches, while the other goes to 19 inches.

This indicates something wrong, and demands a search for the origin of the unequal motion. First ascertain if the rocker-arm is not sprung. If that is all right, examine the link, which is probably sprung out of its true radius. To straighten the rocker-arm is an easy matter, but not so with case-hardened links; although some men are very successful in springing them back. Where it is impracticable to remedy an unequal cut-off by correcting the origin of the defect, several plans may be resorted to for obtaining the required adjustment. One of the most common resorts is to equalize the forward motion by throwing out the back motion. Putting the rocker-arm away from its vertical position when the valve is in the middle of the seat, by shortening or lengthening the valve-rod, provides a means of adjustment. Sometimes the equality of lead opening is sacrificed to obtain equality of cut-off. The changes necessary to obtain adjustment of a distorted motion can only be successfully arranged by one who has experience in valve-setting or in valve-motion designing.

In many shops the cut-off is adjusted for the point where the engine does most of the work,—say at from  $\frac{1}{4}$  to  $\frac{1}{3}$  of stroke. Other master mechanics direct the equalization to be made for half stroke, while some take the mean between the half stroke and the ordinary working notch.

The final adjustments in valve-setting ought to be made when the engine is hot.

## CHAPTER XVIII.

### THE WALSCHAERT VALVE GEAR.

#### INVENTING RADIAL MOTIONS.

DURING the first two decades of general railway operating, from 1830 to 1850, one of the most important problems worked on by locomotive engineers was striving to produce a reversing and valve actuating mechanism that would distribute the steam evenly and give fair durability in service. Many wonderful contrivances were produced that received application through influential friends and were kept in operation long enough to show dreadful examples concerning the evils of complicated valve gear.

#### MELLING'S RADIAL MOTION.

When the agitation devoted to improving valve mechanism was almost in its infancy, the first of what afterwards became known as "radial" motions first appeared. About 1832 a Mr. Melling connected with the Liverpool and Manchester Railway devised the motion shown in Fig. 19. The principle most claimed for this species of valve motion was, that the use of eccentrics was dispensed

with. The inventor secured a pin on the middle of the connecting-rod, which, by the nature of connecting-rod motion, describes a species of elliptic curve, since

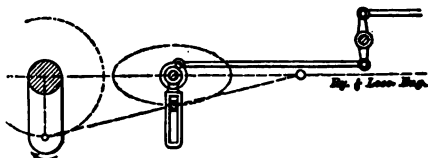

FIG. 19.

become familiar to engineers through the action of Joy's motion, developed years afterwards. The pin worked in a slotted lever, of which the axis was placed in the centre of the ellipse.

The motion did not become popular, probably on account of its novelty, although it appeared to be a decided improvement over the labyrinth of rods, levers, pins, slots, and hooks used as valve motion by many early locomotive builders.

#### HAWTHORNE'S RADIAL MOTION.

Five years after Melling's Motion was first introduced

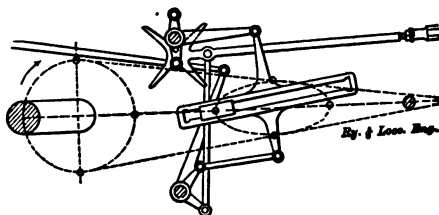

FIG. 20.

the Hawthornes, a noted firm of locomotive builders, introduced the radial gear, shown in Fig. 20. It was

a decidedly complex gear, its only small merit being that no eccentrics were necessary. This gear, like Melling's, was actuated by a pin on the connecting-rod which worked in a long slotted link that transmitted only the vertical motion of the pin to the valve-levers. The lap and lead were obtained by adjustment of the slotted link.

The motion was applied to engines for several years, but never attained popularity.

A variety of radial valve-motions gradually worked their way into favor on continental European railways, but American railway master mechanics displayed no tendency to depart from the well-tried eccentric, although improving valve-motion was a hobby with many of them. The first radial motion used in the United States was on some locomotives built by the Niles Locomotive Works of Cincinnati, for the Beaver Meadow Railroad. The motion, practically Walschaert's, was designed by John L. Whetstone, superintendent of the works.

#### THE WALSCHAERT VALVE GEAR.

The Walschaert valve gear was invented by Egide Walschaert, a Belgian engineer, in 1844. It was applied to a few locomotives shortly after being invented, but grew into popularity very slowly. About 1860 this gear began to find patronage among the locomotive engineers of Continental Europe, and it gradually pushed the link motion to the background.

## MASON'S WALSCHAERT GEAR.

The first American locomotive builder to appreciate the merit of the Walschaert motion was William Mason, who, in 1875, applied it to a locomotive which was exhibited the following year at the Centennial Exhibition. The motion was afterwards applied to many narrow gauge locomotives in the form shown in Fig. 21.

The main link *N* was worked from a crank in the main crank-pin, which was several inches outside of the center

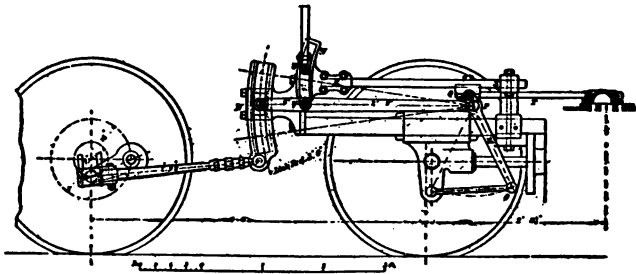

FIG. 21.

line of the valve-seats inside of the center of the cylinders, lever *PO* worked from the cross-head, and to which the radius arm *NP* was coupled, was connected to the block *Q*, which was bolted to the guide-bar *RS*. The lever *PO* was connected to the outside of the block *Q*, which was fastened to the guide-bar, and the valve-stem *T* was attached to it on the inside. By this means the motion of the lever *PO* was transferred to the centre of the valve-stem and valve-seat, which was  $3\frac{1}{2}$  inches inside of the center of the cylinder.

As the point of suspension of the radius arm *NP* has

a great influence on the motion of the valve, the upper end of the link *UV*, to which the radius arm was hung, was attached to a block which worked in the slot of a stationary link or guide *W*. By that means the point of suspension *U* conformed to the curve of the slot, producing nearly uniform distribution of steam at both ends of the cylinder.

In introducing the Walschaert valve gear William Mason was in advance of current progress. The motion was decidedly unpopular among railroad men, principally because it was not understood.

Time brought revenge for the neglect heaped upon the Walschaert valve gear when it was first urged upon American railroad master mechanics. During the year 1904 several railroad companies consented to use the Walschaert motion on heavy multi-coupled locomotives, because being located outside of the running gear, it was much more convenient to reach than link motion placed between the wheels. Those who used the motion were highly satisfied with its performance. The motion is considerably lighter than the link with its connections, and its use enables the frames to be braced more securely than what is possible with motion located inside the wheels. These advantages have made the Walschaert valve gear highly popular, and it is coming rapidly into use.

#### MODERN WALSCHAERT VALVE GEAR.

The following particulars about the Walschaert valve gear, abridged from a paper contributed by Mr. C. J. Mellen to the American Railway Master Mechanics



Association, will make the action of the motion clear to all intelligent readers:

The motion of the valve is derived from two sources, namely, the main crank by connection to the cross-head and from an eccentric placed approximately at right angles to the main crank. The cross-head connection imparts the motion of the lap and lead at the extremities of the stroke of the piston, at which moment the link is in its central position. Therefore in the mid-gear with the reverse lever in its center notch this will be all the motion imparted to the valve and the radius bar becomes stationary. The link is curved to a radius equal to the length of the radius bar. By moving the reverse lever forward the eccentric motion is brought into combination with the motion from the cross-head, producing a valve opening for the forward motion of the engine, and by moving the reverse lever backward the link block is brought to the opposite side of the link fulcrum, resulting in a valve opening governing the backward motion of the engine. The action of this one eccentric is therefore the same as if it was two eccentrics, one for forward and one for backward motion, placed diametrically opposite each other, and the angle of advance is taken care of by the main crank in the cross-head connection. The latter motion being constant, it follows that the lead remains constant at all points of cut-off.

The proportions of the various parts of the Walschaert gear cannot be determined experimentally, nor should any change in setting the valves be made unless the effect of the change is known in advance. It is therefore important that the different parts should be made and

set correctly from the beginning and there will then be no need for changes when the original dimensions are maintained. The difference in this gear for outside and inside admission-valves must be considered in setting

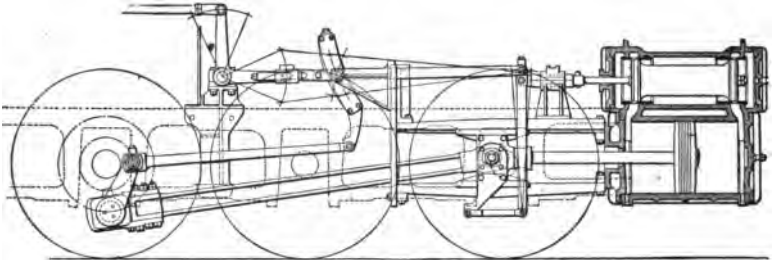

FIG. 22.

the eccentric crank, and as the forward motion of the engine should preferably be taken from the lower end of the link when the eccentric crank will follow the main

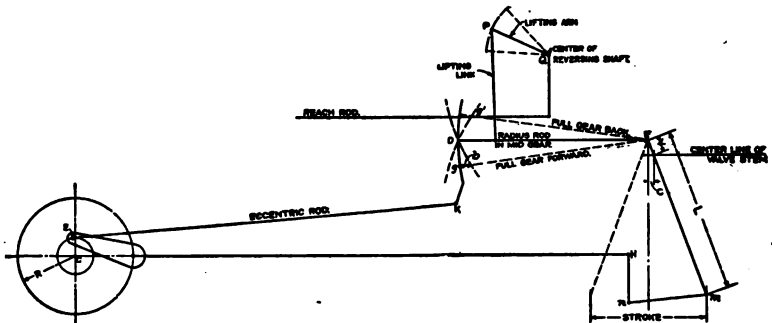

FIG. 22a,

crank for inside admission-valve, Figs. 22 and 22a, and lead the main crank for outside admission-valve, Fig. 23. The connecting point of the radius bar to the combination

lever is above that of the valve-stem connection for inside admission and below the valve-stem connection for outside admission-valves, Figs. 22, 22*a*, and 23. The desired maximum cut-off, lead, and valve travel determines the size of the lap, and thereby the lap and lead motion obtained by the corresponding proportioning of the combination lever, and is found from the following formula:

$$R:C=L:V.$$

$R$ =radius of the main crank.

$C$ =lap and lead (one side).

$L$ =distance between radius bar and cross-head connection, from  $F$  to  $M$ , Fig. 22*a*, on the combination lever.

$V$ =distance between the radius bar and valve-stem connections.

The length of the combination lever must be taken to suit the conditions under consideration in each case,

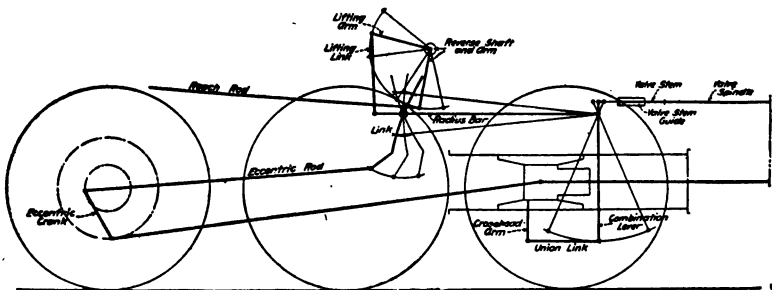

FIG. 23.

so that the angle through which it oscillates will not exceed  $60^\circ$ , but less is preferable. The required horizontal movement or travel of the connecting point  $F$  of

the radius bar to the combination lever for a given maximum valve travel must now be ascertained and is found by the following formula, in which  $R$  and  $C$  are the same as above, namely:

$R$  = radius of main crank.

$C$  = lap and lead.

$a$  = half of the travel of the valve.

$b$  = half of the travel of point  $F$ .

$b = \frac{R\sqrt{a^2 - C^2}}{R + C}$  for outside admission, and

$b = \frac{R\sqrt{a^2 - C^2}}{R - C}$  for inside admission-valve.

These may also be laid out graphically as per Fig. 24 for outside, and Fig. 25 for inside admission-valves, by

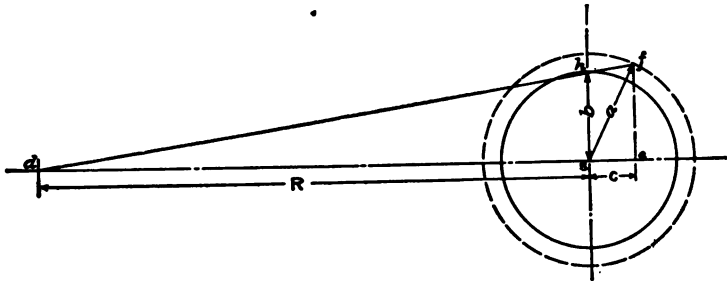

FIG. 24.

drawing a circle with  $S$  as a center and  $a$  radius (shown dotted in the figure). Lay out crank radius  $R$  to the left from  $S = Sd$  and the lap and lead dimension  $C = se$  on same side of  $S$  for inside admission, Fig. 25, and on opposite side of  $S$  for outside admission, Fig. 24. Draw  $ef$  and  $Sh$  perpendicular to  $Sd$ , when  $f$  becomes the inter-

secting point between the valve travel circle and the line  $ef$ . Draw the line  $df$  where this intersects the line  $Sh$ , which point we will call  $h$ , found by extending  $df$  in Fig. 25;  $Sh$  is then the desired dimension,  $b$  in the formula, or one-half the required movement of point  $F$ , the total of which is represented by the full drawn circle in the figures.

This is a most important function of the gear upon which practically all the others depend, and, is rather complicated to find by plotting. With a correct suspension of the link block it will have the same horizontal movement as the point  $F$ , and by limiting the angle of the swing of the link to  $45^\circ$  as a maximum, we get the rise or depression of the link block on either side of the

link fulcrum the distance  $Og = \frac{b}{\tan d}$ , Fig. 22a, where  $O$  is the link fulcrum,  $d$  = one-half of the swing of the link in degrees, and  $b$  = half the travel of point  $F$  in the previous formula.

The vertical location of the link fulcrum  $O$  should be, when practicable, on a line drawn through point  $F$  parallel with the valve-stem, and the eccentric-rod connecting pin  $K$  to the link should be as nearly as practicable on the same level as the main axle in order to minimize the effect of the vertical play of the axle on the valve events, but on large engines it may be found necessary to lower fulcrum  $O$  and raise connection  $K$  to avoid excessive throw of the eccentric crank.

In locating the longitudinal position of the link fulcrum, consideration must be given to the lengths of the eccentric and radius bars, so that both may be of approximately

the same length. When these lengths fall below three and one-half times the total vertical sweep of the link block, the radius bar should be favored in preference to the eccentric rod. The exact position of the eccentric crank must be plotted as well as the longitudinal location

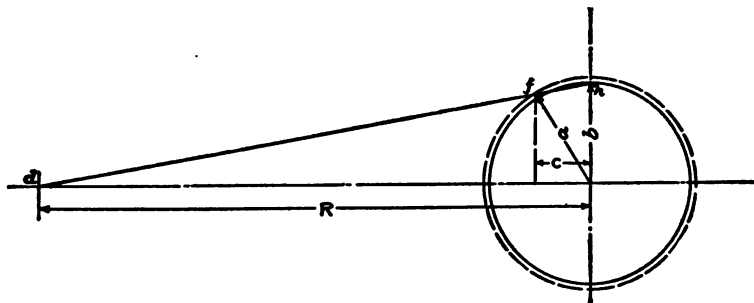

FIG. 25.

of point  $K$ . The former must bear such relation to the main crank that it brings the link in its middle position when the main crank is on either of its dead centers and the connecting point  $K$  must be so located that it swings the link in the required angle  $d$  on either side of the middle position of the link; that is, in other words, the point  $K$  should be so located on the curve it must follow with fulcrum  $O$  as a center that its deviation from the tangent of the eccentric-rod to this curve is such that it as near as practicable compensates for the irregularities brought about by the angularities of the main and eccentric rods which in ordinary cases brings it from 2 inches to 5 inches in the rear of the tangent to the link drawn through the fulcrum  $O$ .

The locus of the suspension point of the radius bar lifting link must also be plotted so that the link block

is at the same point of the link in its extreme positions at all cut-offs. This locus is a curve with its center in the vicinity of the point  $F$  when in its mid-gear position. It would be impracticable, however, to have a lift arm of this length, and a curve of smaller radius must be substituted and so applied that it intersects with the former curve at points giving the least possible distortion to the motion favoring the position of the link block in which it is mostly used in service.

The sliding-lifter, shown in Fig. 22, meets these conditions better than any other method of suspension, but, due to wheel arrangements of various designs of engines, this is not always applicable, but must be substituted by swinging lifters, as per Figs. 22*a* and 23, which, when properly plotted, give for all practical purposes equally good results.

The vertical height of lower connection  $m$  of the combination lever in relation to the cross-head connection has a slight influence on the port opening and should, therefore, in the center position of the lever, be about in the same level as the cross-head connecting point  $n$ , Fig. 23.

#### GENERAL NOTES FOR ADJUSTING WALSCHAERT GEAR.

1. Ascertain by the following method the position of the eccentric crank: Mark the position of the link relative to its middle position on both of the dead centers of the main crank. If the position of the link is the same in both cases the eccentric crank position is correct; if not, the eccentric crank should be shifted until this occurs, or as near so as possible.

2. After the eccentric crank has been correctly set the eccentric-rod should be lengthened or shortened as

may be required, to bring the link in its middle position, so that the link block can be moved from its extreme forward to its extreme backward position without imparting any motion to the valve. It may be noted that the link position may be observed by the usual tram-marks on the valve-stem, or direct by marks on the link-pin, as may be found most convenient, with the link blocks in full gear, preferably ahead.

3. The difference between the two positions of the valve on the forward and backward centers of the engine is the lap and lead doubled; it is the same in any position of the link block, and cannot be changed by changing the leverage relations of the combination lever.

4. The tram-marks of the opening moments at both ends of the valve should be marked on the valve-stem, and the latter lengthened or shortened until equal leads at both ends are obtained.

5. With certain limits this lengthening or shortening may be made on the radius bar, if it should prove more convenient, but it is desirable that its length should be so nearly equal to the radius of the link that no apparent change in the lead should occur in moving the link block, as stated in note No. 2.

6. The lead may be increased by reducing the lap, and the cut-off points will then be slightly advanced. Increasing the lap produces the opposite effect on the cut-off and reduces the lead the same amount. With good judgment these quantities may be varied to offset the irregularities inherent in transforming rotary into lineal motions.

7. The valve events are to a great extent dependent on the location of the suspension point of lifter of the rear



end of the radius bar, when swinging lifter is used, which requires that this point should be properly laid out by careful plotting, or, if convenient, it is preferably determined by a model, as irregularities due to incorrect locus of this point cannot be corrected by the other parts of the gear without more or less distortion of same. When this point is so fixed that a change of same is impracticable, it may be better, however, to modify other elements, if thereby the motion in general can be improved.

#### VALVE SETTING.

The Walschaert valve gear is so designed in the drawing office that very little valve setting or adjustment is necessary, but some minor changes have generally to be made on the new parts. This is done principally by the return crank and the valve-stem. When the engine is erected, the return crank is not permanently secured to the pin, but is left ready for adjustment. The valve-stem can be lengthened or shortened by means of a nut that acts like a turn-buckle. When the exact length of the valve-stem is determined, a hole is drilled through the adjusting-nut, and the valve-stem, and a pin driven through, which makes that adjustment permanent. When the proper setting of the valve has been ascertained by trials, the return crank is marked for the key-seat which is afterwards cut. In adjusting the valves it is sometimes necessary to lengthen or shorten the rod connecting the return crank with the link.

When a Walschaert valve motion becomes distorted through wear, the only remedy is renewing the bushings. No other changes ought to be attempted.

## CHAPTER XIX.

### TRACTIVE POWER AND TRAIN RESISTANCE.

#### HOW TO CALCULATE THE POWER OF LOCOMOTIVES.

THE practice of tonnage-rating, which has been steadily growing in favor for the last few years, has set many officials, outside of the mechanical departments, to figuring upon the power of locomotives, and on the trains all kinds of engines ought to haul over certain divisions. To meet this demand I have determined to write particulars by which any man, knowing the first four rules of arithmetic, can figure out for himself the tonnage that any locomotive can haul on any grade or curve. The information to be given is found in other engineering-books, but many railroadmen do not know where to look for the technical data they need.

#### HORSE-POWER OF STEAM-ENGINES.

The power capacity of steam-engines is generally expressed in horse-power, which is a measurable quantity and is based on the arbitrary measure of one horse-power being equal to the effort of raising 33,000 pounds one foot per minute. That is the unit used

for measuring the power transmitted by nearly all kinds of prime motors and machines. It is sometimes applied to locomotives, but for a variety of reasons the horse-power capacity of a locomotive does not convey to the ordinary railroad mind its capacity for hauling different kinds of trains. The utility of a locomotive for train-pulling has to be expressed in a different way.

#### HOW PRACTICAL RAILROADMEN ESTIMATE POWER OF LOCOMOTIVES.

When practical railroadmen know the size of cylinders, the diameter of driving-wheels, the weight resting upon them, and the boiler dimensions, they understand what kind of service the engine is adapted for, and in a general way what weight of train it will haul. A general idea of power is, however, a guess which may be considerably away from the truth. Guessing is not a good basis for designing or estimating the power of a locomotive, and so methods have been devised for figuring out the power and speed that certain dimensions will develop which are as correct and reliable as any other engineering rules. It has become customary to reckon the power of a locomotive by the tractive force the driving-wheels will exert upon the rail—that is, the resisting weight which the engine will start from a state of rest.

#### ADHESION AND TRACTIVE POWER.

The tractive force is the power which the pistons of a locomotive are capable of exerting through the driv-

ing-wheels to move engine and train. The efficiency of the engine's tractive power is dependent upon the adhesion of the wheels to the rails. When adhesion is insufficient, the power transmitted through the pistons and rods will slip the wheels, and no useful effect will result. To prevent the slipping of locomotive driving-wheels, it is necessary to put resting upon them at least four times in weight the force available for turning them. If the weight is five or six times the piston power, the engine will do its work with less annoyance from slipping than would be the case with less weight. To prevent slipping on unwashed, greasy rails, more than double the adhesion would be necessary for that required on dry, clean rails. This cannot often be done, but the sand-box provides the means for obtaining adhesion when the rails are in bad order.

#### FIGURING PARTICULARS OF TRACTIVE POWER.

Let us calculate the tractive power of the kind of engine most commonly used for hauling heavy passenger and fast freight trains, which has cylinders  $19 \times 26$  inches, driving-wheels 69 inches diameter, with a working pressure of 200 pounds to the square inch. The method by which the traction of a locomotive is calculated is to square the diameter of the cylinders in inches, multiply that by the length of the stroke in inches, and divide by the diameter of the driving-wheels in inches. The product of that sum will be the power exerted by the engine for every pound of pressure that reaches the cylinders from the boiler.

A rule established by the Railway Master Mechanics' Association makes out that 85 per cent of the boiler-pressure is a fair average of what pressure will be available in the cylinders at slow speed.

Follow that rule and the formula whereby we have described the method for finding out the tractive power of this particular locomotive would be

$$T = \frac{d^2 L p}{D},$$

which means

$d$  = diameter in inches squared;

$L$  = the length of stroke in inches;

$p$  = the mean effective pressure on piston;

$D$  = the diameter of the driving-wheels in inches;

$T$  = the equivalent tractive force at the rails in pounds.

To apply this rule in practice, we find that  $d^2$  means multiply 19 by itself, or square, so we have  $19 \times 19 = 361 \times 26$  (the stroke in inches) =  $9386 \times 170$  (mean effective pressure) =  $1,595,620 \div 69$  (the diameter in inches of driving-wheels) = 23,125. This gives 23,125 pounds as the power exerted at the circumference of the wheels, from which a deduction of about 10 per cent is usually made for internal friction. We have assumed the boiler-pressure to be 200 pounds and have used 85 per cent of it.

The formula described seems at first sight theoretical, and not based on a good philosophical foundation; but it is merely a short way, and agrees in results

with more detailed methods of calculation. It agrees with another plan which is more in favor with civil engineers. That is, to ascertain the foot-pounds of work the engine is doing during each revolution of the driving-wheels. By dividing the total thus found by the circumference of the drivers in feet the force exerted through each foot which the engine moves is found.

CIVIL ENGINEERS' METHOD OF CALCULATING  
TRACTIVE POWER.

Taking the same engine that we have figured on, with pistons 19 inches diameter, the area of one piston is 283.5294 square inches. This is multiplied by the mean average pressure of the steam, giving  $283.5294 \times 170 = 48,199.9980$ , which gives the aggregate pressure exerted by the steam on one piston. Multiplying that by 2 to take in both pistons, we have  $96,399.9960 \times 4\frac{1}{2}$  feet (the stroke moved in a full revolution of the driving-wheels)  $= 417,733.3160 \div 18.0642$  (the circumference of the driving-wheels in feet)  $= 23,125$  pounds tractive force, the same as by the other rule.

There are several other methods of calculating locomotive tractive power, but they need not be described, as they bring precisely the same figures as those found.

FINDING THE HORSE-POWER OF A LOCOMOTIVE.

When people wish to find the horse-power developed by a locomotive at various speeds, the steam-engine

indicator is usually employed to show the mean effective pressure inside of the cylinders. To explain the process to be followed, we will draw on our own experience with a representative locomotive pulling a fast passenger train.

The writer took indicator-diagrams to find out the amount of work done by the locomotive in taking the Empire State Express over the New York Central Railroad. The details were published in *Locomotive Engineering*, June, 1892. A very common speed was 60 miles an hour. The engine had cylinders  $19 \times 24$  inches, and driving-wheels 78 inches diameter. The indicator-diagram proved that the average cylinder-pressure at 60 miles an hour was 53.7 pounds per square inch. The horse-power is calculated in the following manner:

$$\begin{array}{r}
 283.5294 \text{ square inches piston area;} \\
 \underline{53.7 \text{ pounds M.E. pressure;}} \\
 15,225.5 \text{ pressure on one piston;} \\
 \underline{2 \text{ pistons;}} \\
 30,451 \text{ pressure transmitted from both cylinders;} \\
 \underline{4 \text{ feet piston-travel in each revolution;}} \\
 121,804 \\
 \underline{260 \text{ revolutions per minute;}} \\
 31,669,040 \div 33,000 = 959 \text{ horse-power.}
 \end{array}$$

That method of calculation, of course, applies to all locomotives, and can be used when the area of piston, revolutions per minute, and mean effective cylinder-pressure are known.

In the case recorded the mean effective cylinder-pressure was little more than 33.5 per cent of the boiler-pressure. When the same engine was running at 37.1 miles an hour, making 160 revolutions per minute, the M.E.P. was 59.2 pounds, and 37 was the percentage of boiler-pressure. At 20 revolutions per minute the mean effective pressure would be little short of the 85 per cent of boiler-pressure of the master mechanics' rule, but it would gradually decrease as the piston speed increased.

The work that a locomotive has to do in pulling a train is described under the heading of Train Resistances.

#### TO CALCULATE THE POWER OF COMPOUND LOCOMOTIVES.

To calculate the tractive power of compound locomotives, it is necessary first to know what the mean effective pressure on the pistons is in every case, and any attempt at a theoretical exposition of the methods for arriving at this information by calculation is very unsatisfactory and inaccurate, for this reason: In the case of the two-cylinder compound there are too many unknown quantities, among which are the volume of receiver, pressure of live steam through reducing-valve, and the amount of back-pressure. In the case of the four-cylinder compound there is no receiver, but the element of back-pressure is present on the high-pressure piston. For these reasons calculated pressures are not reliable for finding the power of this type of engine. The indicator furnishes the



means to arrive at the correct mean effective pressure, and the formula for a two-cylinder compound when the mean effective pressure is known is

$$\frac{d^2 \times \text{M.E.P.} \times s}{2 \times D}$$

in which  $d^2$  = diameter of low pressure squared, M.E.P. = mean effective pressure,  $s$  = stroke in inches, and  $D$  = diameter of driving-wheel. In the absence of indicator-cards showing cylinder-pressures for a given boiler-pressure, approximate results may be had by taking the mean effective pressure in the high-pressure cylinder at 70 per cent of boiler-pressure, which for 200 pounds boiler-pressure would be 140 pounds. If the reducing-valve gives steam to the low-pressure cylinder so as to equalize the work on both the pistons, the low-pressure cylinder will have a mean effective pressure of about 60 pounds for a ratio of cylinder of 2.3, which is the ratio between 23- and 35-inch cylinders. Referring the mean effective pressure to terms of the low-pressure cylinder, we have

$$60 + \frac{140}{2.3} = 60 + 61 = 121 \text{ pounds.}$$

Placing the values in the formula, the tractive power equals

$$\frac{35^2 \times 121 \times 32}{2 \times 55} = 43,120 \text{ pounds.}$$

If a deduction of 7 per cent for internal friction is made, the net tractive power is about 40,000 pounds.

The tractive power of the four-cylinder compound is also found by taking mean effective pressures known to have been found in service. These may be taken at 44 and 46 per cent of the boiler-pressure for the high- and low-pressure cylinders, respectively, which for 200 pounds gauge-pressure equals 88 and 92 pounds mean effective pressure. Taking, for an example, an engine with high-pressure cylinders 18 inches diameter, low-pressure cylinders 30 inches diameter, stroke 30 inches, and diameter of drivers 55 inches, the ratio of cylinder areas is 2.77; and again referring the pressures to the low-pressure cylinder we have  $92 + \frac{88}{2.77} = 123$  pounds mean effective pressure in the low-pressure cylinders. Placing these values in the formula, which in this case is somewhat different from the other, owing to the fact that there are now two cylinders to consider instead of one, we have

$$\frac{30^2 \times 123 \times 30}{55} = 60,300 \text{ pounds.}$$

Taking out 7 per cent for friction, as before, the tractive power is about 56,000 pounds. For their four-cylinder compounds the Baldwin Locomotive Works take  $\frac{2}{3}$  of the boiler-pressure for the mean effective pressure in the high-pressure cylinder, and  $\frac{1}{4}$  for the mean effective pressure in the low-pressure cylinder; for two-cylinder compounds take  $\frac{2}{3}$  of the boiler-pressure for the mean effective pressure for the high-pressure cylinder. The variation between high- and

low-pressure cylinders in the two-cylinder type will, of course, be compensated by the reduced mean effective pressure in the low-pressure cylinder.

#### RESISTANCES OF TRAINS.

The work which a locomotive performs in pulling a train is expended in overcoming the resistance due to wheel-friction, gradients, curves, and atmospheric or wind pressure. Ever since railroad trains began to be operated engineers have been striving to devise formulæ for showing the train resistance at various speeds. From what we have found out in investigating this subject we do not believe that it is possible to devise a formula that will show an approximation of the resistance due to different kinds of trains at different speeds when train-tons are the basis of calculation.

The character and the load of the cars have a decided influence upon the resistance per ton of the train. Thus records made on the Chicago, Burlington & Quincy by the aid of the dynamometer-car and indicator-diagrams taken from the locomotive showed that with a train of loaded freight cars weighing 940 tons, running at a speed of 20 miles an hour, the average resistance on a straight, level track was  $5\frac{1}{2}$  pounds to the ton. A train of empty freight cars weighing 340 tons run at the same speed showed an average resistance of about 12 pounds to the ton.

There is good reason for believing that the heavier the cars in a train are loaded the smaller the ton resistance is, just as was cited in the case of the loaded

and empty cars. A particularly heavy train of freight cars, weighing, with engine and tender, 3428 tons, pulled over the New York Central, to test the power of a new type of locomotive, indicated that the resistance at 20 miles an hour was about 4 pounds per ton.

We have collected a great mass of information concerning the resistance of trains, and careful study of the facts convinces us that to show an approximation of the resistance of different kinds of trains it is necessary to treat every one separately. The late A. M. Wellington, of the *Engineering News*, devoted a great deal of study to the subject of train resistances, and in his day was probably the best living authority thereon. In 1892 the author took steam-engine indicator-diagrams from an engine pulling the Empire State Express, and in publishing them made some deductions about the resistance of the train. Mr. Wellington took the figures presented and compared them with records made by William Stroudley with express trains on the London, Chatham & South Coast Railway. From that and other data he worked up a diagram of train resistances particulars of which will be given.

While investigating the power of locomotives required to pull certain heavy fast express trains Mr. S. A. Vauclain, of the Baldwin Locomotive Works, carried on a series of independent experiments, and he found the train resistances a little less than those formulated by Wellington; but he expressed the belief that Wellington's figures were near enough for all practical purposes.

From the facts which we have obtained from dynamometer-car records and other sources that may be relied on to be nearly correct we have worked out the two lines added to the Wellington and Vauclain formulæ given in the subjoined table:

RESISTANCE PER TON OF 2000 POUNDS.

Miles per Hour.	10	20	30	40	50	60	70
Resistance in pounds per ton.							
Heavy passenger train :							
Wellington.....	4.5	6	9.5	12	14	17	19
Vauclain.....	.....	.....	.....	.....	11	13	15
Loaded freight cars.....	4	5.8	9.2	11.3	12.5	.....	.....
Empty freight cars.....	6	7.5	11	14	17	.....	.....

These figures apply to trains running on a straight, level track on a calm day.

The factors of train resistance due to grades are exact. If the steepness of the grade in feet is multiplied by 0.38, the quotient will be the resistance in pounds per ton. Suppose the grade is 1 per cent, or 52.8 feet to the mile, we have the problem  $52.8 \times 0.38 = 20$ , the number of pounds per ton for that grade. If the train with engine and tender weighs 1000 tons, 20,000 pounds of tractive power will be required to overcome the resistance due to gravity.

Curves increase the train resistance of trains to an extent that depends very much upon the physical condition of the curve and upon the length of train that is upon it in getting round it. The allowance generally made for the resistance of curves is  $\frac{1}{2}$  pound per ton for each degree of curvature.

## CHAPTER XX.

### DRAFT APPLIANCES.

#### ORDINARY ARRANGEMENTS FOR CREATING DRAFT.

THE capacity of the boiler for generating steam with great rapidity was what made high-speed locomotives a possibility. The filling of the boiler with small flue-tubes and the employing of a strong artificial draft were the principal means used in making the locomotive boiler a success. Various methods were for a time tried in maintaining the strong draft necessary; but it is now generally admitted that the emission of the exhaust-steam through the smoke-stack is the most efficient and simple means of creating the pull on the fire necessary to generate the great volume of steam used by the cylinders of a locomotive.

The ordinary arrangement of draft appliances is as simple as it is efficient. Referring to the illustration Fig. 40, the fuel rests on the grates *uu*, and receives through the grate-openings the air necessary to sustain and stimulate combustion. The gases released from the burning fuel pass up into the body of the fire-box *BB*, thence into the flue-tubes *xxx* to the smoke-box

*CC*, from whence they pass to the atmosphere by the smoke-stack *D*. In traversing this route the fuel-gases impart the greater portion of their heat to the water surrounding the sheets and flues; and the greater the proportion of the heat imparted to the water the greater is the efficiency of the boiler. There is a

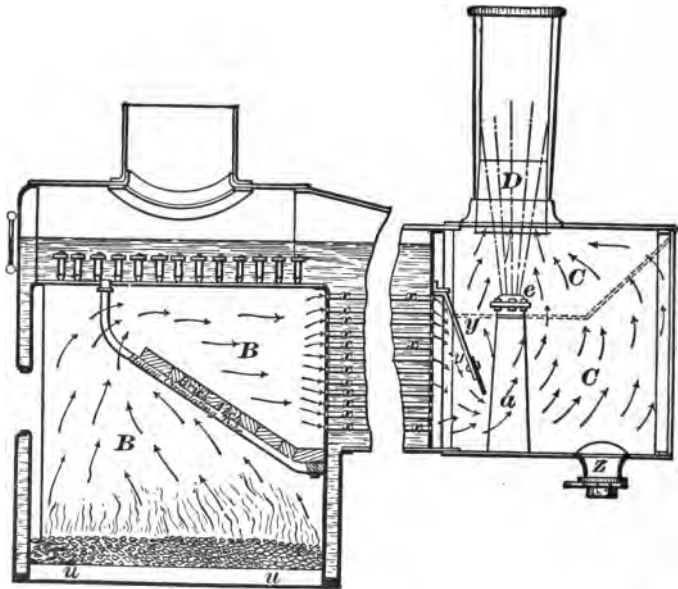

FIG. 40.

remarkable difference in the faculty of boilers for absorbing the heat of the fire-gases, and not a little of this difference is due to the design and arrangement of the draft appliances.

Locomotive engineers and firemen do not design or make the draft appliances of the engines they operate;

but they have a great deal to do with adjustments of the same, and an intelligent study of the action of the draft appliances may often save them from much unnecessary labor, and the company from useless expense.

#### ACTION OF THE DRAFT-CREATING FORCES.

When a locomotive is at work the steam passes through the exhaust-pipe *a* through the nozzle *b*, and shoots up through the stack like a projectile, the velocity depending on the pressure of the steam released, and on the size of the nozzle-opening through which it has to pass. The greater the quantity of steam passing through the cylinders, the greater, under ordinary circumstances, will be the draft induced.

Draft by the exhaust-steam passing from the exhaust-pipe through the smoke-stack appears to be created in two ways. The steam acts partly on the surrounding air or gases it passes through to induce a current by friction of the particles; or, on the other hand, its compact volume fills the smoke-stack like a piston, inducing draft by leaving a partial vacuum behind like the action of a pump-plunger. Whether the current be induced by friction or by the piston-like action, the air in the smoke-box is rarefied, and there being only one means of ingress to fill the partial void, the pressure of the atmosphere forces air through the grates into the fire in its passage to the smoke-box by way of the tubes.

Inducing a current by friction is the principle the



steam-jet works on, and when that is the mode of the exhaust action in maintaining draft the nozzle is merely an enlarged jet-opening. There is no doubt that when the exhaust-steam acts like a plunger in the smoke-stack to leave a partial vacuum behind, a more perfect draft can be maintained with the same steam velocity than where the draft is created by friction; yet the latter practice of draft induction is largely followed in American locomotives. In ordinary working at moderately high piston speed the exhaust acts in both ways. At low speed the plunger action alone ought to provide the required draft.

#### DIFFERENT WAYS OF PASSING EXHAUST-STEAM INTO THE STACK.

Under whatever conditions a locomotive is worked, the intensity of draft created by a given volume or velocity of exhaust-steam will depend, to a great extent, upon the way the nozzle or nozzles and their connections pass the steam into the stack. If the steam passes centrally into the stack in a compact form, and expands on its passage just enough to fill the stack at its base, a low tension of exhaust-steam will serve to leave a comparatively high vacuum behind, which will instantly be filled by the gases that pass through the flues. This perfect action of the exhaust-steam in creating draft is not so general as it ought to be.

In Fig. 41 the escaping steam is shown expanding sufficiently to fill the stack just as it enters the base casting. When this happens, the stack acts like a

pump-barrel delivering a full charge at each stroke. In such a case, a stackful of gas is pumped out of the smoke-box with every exhaust, and the vacuum necessary for making steam will be maintained with a low velocity of exhaust-steam, which means that a large nozzle may be employed.

The steam is sometimes delivered in such a form that it does not fill the stack till it is half way up. The exhaust-steam in this case will pump only about

a half stackful out of the smoke-box with each puff of steam, and the necessary vacuum will be maintained partly by the pumping action and partly by friction of the escaping steam on the gases. A higher steam velocity is required to create the needed draft in this case.

Fig. 42 illustrates a defect of exhaust action very common where double nozzles are used. Its effect is similar to that mentioned in the last paragraph; but in some cases it is much worse, for the exhaust-steam hugs the side of the stack the whole way up, and by that means loses a portion of its draft-creating power. This same effect sometimes comes from a single nozzle being set out of plumb.

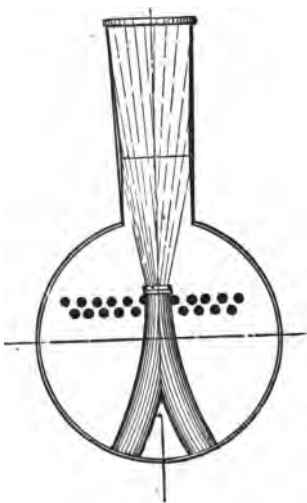

FIG. 41.

Fig. 43 illustrates another pernicious form of bad adjustment. In this case the steam strikes wide at the base of the stack, and delivers some of its volume

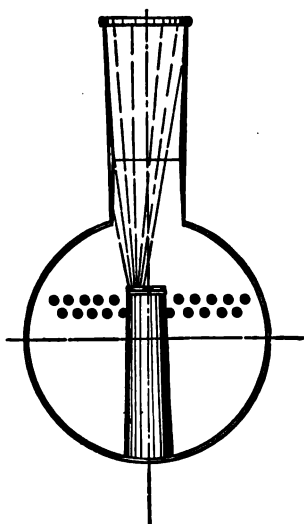

FIG. 42.

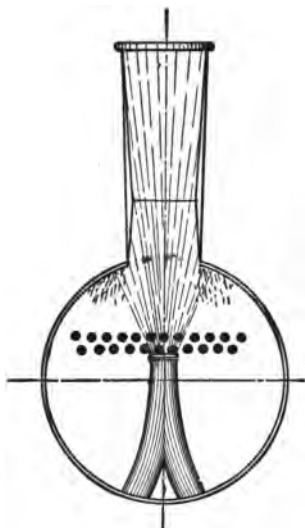

FIG. 43.

into the smoke-box, which impairs the efficiency of the pumping action.

Although in these illustrations I have used only the open stack, the defects pointed out apply equally well to engines having low nozzles, petticoat-pipes, and diamond stacks.

#### EXHAUST-PIPES AND NOZZLES.

The first function of an exhaust-pipe is to convey the used steam from the cylinders. The form that will carry off the steam so that the least possible

degree of back-pressure is left to obstruct the piston is the best for locomotives. The best form that can be used will cause considerable back-pressure at high piston speeds. When the exhaust-pipe is designed to open at the bottom of the smoke-box, it is necessary to use double nozzles, to prevent the presence of severe back-pressure in the cylinders caused by the steam passing through the exhaust-pipes from one cylinder into the other. The two pipes come together below in such a shape that this cannot be prevented.

When double nozzles are used with a high exhaust-pipe, the greatest possible care should be taken to adjust the nozzles to deliver the steam as nearly central in the stack as possible. When an engine having this arrangement is not steaming satisfactorily, it is a good plan to watch how the steam strikes in the stack.

Where a high exhaust-pipe is used, it is best to employ a single nozzle. Careful experiments have proved that a well-designed exhaust-pipe ending in a single nozzle gives the best results in creating draft; but unless the exhaust-pipe is large and properly shaped, the engine is likely to suffer from back-pressure in the cylinders.

It might naturally be supposed that the arrangement of exhaust which produced the highest vacuum would produce the best results in steam-making; but that is not always the case. Very carefully conducted experiments, carried out to find the relative value of different draft appliances, showed decidedly that a lower smoke-box vacuum would keep up steam with a well-arranged single nozzle than with any form of

double nozzle. The tendency of the double nozzle was to make an uneven vacuum in the smoke-box. That is, there would be a higher vacuum near the place where the exhaust steam passed than at any other part of the smoke-box. This would in its turn lead to the gases crowding towards a certain part of the tube-openings, and have the same effect as a badly adjusted diaphragm-plate.

#### THE PETTICOAT-PIPE.

Where low nozzles are employed, a petticoat-pipe must intervene to convey the steam centrally to the stack. With this combination, the size and shape of the petticoat-pipe must be adapted to the size of nozzles, diameter of stack, and height of smoke-box. In addition to being useful for leading the steam into the smoke-stack, the petticoat-pipe has proved an efficient means of equalizing the draft through the tubes. Unless some regulating device is used to make the gases of combustion pass evenly through the tubes, the stronger rush of the draft will be through the upper rows, and in consequence the lower rows will get choked up with cinders and soot. The petticoat-pipe when properly adjusted is a remedy for this. There is a certain position where the petticoat-pipe will produce the best steaming results, and a very small change from that position will affect the steaming qualities injuriously. A very small change will result in making a big rush of gas through a few tubes, while the others get very little heat to make steam with.

## SMOKE-STACKS.

A recognized rule among us in smoke-stack designing has been to make the stack of a diameter one inch less than the diameter of the cylinder. There is really no proper connection between the diameters of cylinder and smoke-stack; but the rule worked fairly well with diamond stacks, where an inch or two of difference in the diameter of the stack was of little consequence. The diameter and shape of the petticoat-pipe was what had to be carefully watched with a diamond stack.

With an open stack the case is different. The function of the stack is to pass out the gases that are drawn through the grates and flues, and therefore its size ought to bear some relation to the cross-section of flues or to the grate area. To cause the exhaust-steam from a single nozzle to produce draft by the pumping action, the stack must be small enough to permit the compact exhaust-steam to fill it at the base. When the stack is too large for this, an increased exhaust velocity is required to keep up steam. A reduction of stack area away below the diameter of the cylinder will generally permit of the enlarging of the nozzle.

Where the diamond stack is used, the size and shape of the cone and its attachments make a material difference in the steaming qualities of a locomotive, but it is merely a case of great or greater obstruction to the draft. The tendency is to improve the cone by abolishing it altogether; but where that remedy is not

in order, it should be constructed and set so that the gases will not rebound into the cylindrical part of the stack after striking the cone. Where the cone is set low in the diamond this is liable to happen. When the lower angle of the diamond is formed flat, the tendency is to cause an eddy of the escaping gases, which is detrimental to free steaming.

#### THE EXTENSION SMOKE-BOX AND DIAPHRAGM-PLATE.

The purpose of these appliances has been explained fully on preceding pages. The extension front is put on to form a receptacle for sparks; and the diaphragm-plate acts as a guide to lead the sparks forward beyond the point of strong exhaust suction.

The diaphragm is likewise used to regulate the draft through the tubes, and when properly designed it does this work very successfully. It should not, however, be forgotten that the diaphragm is a necessary evil, the same as the cone in the diamond stack, and that under the best possible arrangement it is still an obstruction to draft. Where it can be made to perform its functions of clearing the lower rows of tubes with the least possible obstruction to draft, there the engine will steam most freely, other things being equal. Not a little of the trouble experienced to make engines with extension fronts steam freely has arisen through stupid design and arrangement of the diaphragm. I happened upon a case which illustrates this point. On a first-class road, celebrated for its advanced style of machinery, there was an engine that was noted as a poor steamer. A shrewd engineer took this engine

out, one day, because his regular engine was held in for repairs. The engine steamed badly from the start, and the train was got over the road by slow torture. This engineer, however, knew his business, and as the engine was of the same class as the one he ran daily, he saw no reason why she should not steam equally as well. At the end of the division he opened the smoke-box door for inspection, and the diaphragm was found so far down and so close to the tube-sheet that the draft was badly obstructed. He had it raised to what he considered the proper position, and on the return journey the engine steamed admirably, and threw no fire. On returning to his starting-point, this engineer went to the master mechanic in charge and explained the experience he had gone through with the engine. Was he commended for his intelligence and zeal? By no means. He was told that he had no right to touch the diaphragm. It was set in the standard position, and standards on this road are like the laws of the Medes and Persians—unchangeable. It looked like a case of devotion to standards run to seed. A very slight change in the diaphragm-plate often affects the steaming of an engine as materially as a small change in the position of a petticoat-pipe.



## CHAPTER XXI.

### COMBUSTION.

#### IMPORTANCE OF COAL ECONOMY.

THE coal account of the locomotive department constitutes a very important element in railroad expenditures; it makes a heavy drain upon every railroad in the country. A saving of 15 per cent in the coal account of a railroad might often have been the means of keeping a company solvent that went into the hands of a receiver. A bad fireman generally wastes more than 15 per cent over the quantity of fuel used by a good fireman. We are told that the man who makes two blades of grass grow where one blade used to grow is a benefactor of the human race. As the quantity of coal provided for the use of mankind is limited, and the means of cultivating a fresh supply are not apparent, it would seem that the man who makes one pound of coal do the work that has generally called for the consumption of one and a half pounds is worthy of a share of the admiration accorded to the industrious agriculturist. There are locomotives in the country where the coal consumed, in the generation of steam, is used as economically as knowledge and skill com-

bined can effect, but these cases are not so common as they ought to be. Much has been said and written of late years about proper methods of firing, founded on correct conceptions of the laws that regulate combustion, but a great many of our locomotives continue to be fired in a way that violates Nature's laws, and a senseless waste of coal is the result. The opportunities for firemen mending their ways and earning the distinction of being public benefactors, to say nothing of being better worthy of employment, are innumerable.

There are gratifying evidences that the modern engineer or fireman is striving to acquire the knowledge and the skill that make him thoroughly master of his business. For the help of such men the following chapter has been prepared.

#### MASTERING THE PRINCIPLES.

To properly comprehend what happens to keep a fire burning, we must understand something about the laws of Nature as they are explained under the science of chemistry. Practical men are generally easily repelled by the strange names which they meet with in reading anything where chemical terms are used. An engineer or fireman who is ambitious to learn the principles of his business ought to attack the hard words with a little courage and perseverance, when it will be found that the difficulties of understanding them will vanish.

## SCIENTIFIC FIRING.

A man may become a good fireman without knowing anything about the laws of Nature that control combustion. This frequently happens. If he becomes skillful in making an engine steam freely, while using the least possible supply of fuel, he has learned by practice to put in the coal and to regulate the admission of air in a scientific manner. That is, he puts in the exact quantity of fuel to suit the amount of air that is passing into the fire-box, and in the shape that will cause it to produce the greatest possible amount of heat. When this degree of skill is attained by men ignorant of Nature's laws, it is attained by groping in the dark to find out the right way. A man who has acquired his skill in this manner is not, however, perfectly master of the art of firing, for any change of furnace arrangement is likely to bewilder him, and he has to find out by repeated trying what method of firing suits best. He is also liable to waste fuel uselessly, or to cause delay by want of steam when anything unusual happens.

## KNOWLEDGE IS POWER.

A knowledge of the laws of combustion teaches a man to go straight to the correct method, and the information possessed enables him to deal intelligently with the numerous difficulties which are constantly arising owing to inferior fuel, obstructed draft due to various causes, and to viciously designed fire-boxes and smoke-boxes. To illustrate: Engineer West was

pulling a passenger train one day, and his grates got stuck. He ran as far as he could till he could do nothing more for want of steam, then he stopped and cleaned the fire; loss of time over one hour with an important train. Engineer Thomas, on the same road, had a similar experience with the grates; but he understood combustion, and knew that all the fire wanted was air put in so that it would strike the fire before it passed into the flues. He got an old scoop and rigged it in the fire-box door slanting towards the surface of the fire. He did not need to clean the fire, and he went in nearly on time. He could not get air to mix with the fire through the grates, so he devised a plan to inject it above the fire.

#### ELEMENTS THAT MAKE UP A FIRE.

The nature of fuel, the composition of the air that fans the fire, and the character of the gases formed by the burning fuel, and the proper proportions of air to fuel for producing the greatest degree of heat, are the principal things to be learned in the study of the laws relating to combustion.

All things are composed from about sixty-five elementary substances, which have combined together to form the immense variety of substances found in and around the globe. A simple substance or element is something out of which nothing else can be got, no matter how finely it may be divided, or to what searching tests it may be subjected. Elements unite together to form compounds, or combine with compounds to form other compound substances. When

elements or compounds combine to form new substances, they always do so in fixed proportions by weight; and if there is any excess of any substance present it does not combine, but remains unused. It is important to remember this, as it has a direct bearing upon the economy of fuel. A few of the principal elements are oxygen, hydrogen, nitrogen, carbon, sulphur, iron, copper, mercury, gold, and silver. We will have to deal principally with the four first mentioned.

The elements which perform the most important functions in the act of combustion are oxygen and carbon. Carbon is the fuel, and oxygen is the supporter of combustion. Combustion results from a strong natural tendency that oxygen and carbon have for each other, but they cannot unite freely till they reach a certain high temperature, when they combine very rapidly, with violent evolution of light and heat.

#### FUEL AND ITS COMBINING ELEMENTS.

All the fuel used for steam-making is composed of carbon, or the compounds of carbon and hydrogen. Carbon is the principal element found in trees and in all woody fiber, and is the fundamental ingredient of all kinds of coal. The ordinary run of American bituminous coal contains from 50 to 80 per cent of fixed carbon, which is the coke, and from 12 to 35 per cent of volatile substances, which burn with a lurid flame, and supply the ingredients of coal-gas. These inflammable compounds are known as hydrocarbons, being combinations of hydrogen and carbon. Anthra-

cite coal differs from other coals in the fact that it consists principally of fixed carbon, with but little volatile matter. Good anthracite contains as high as 90 per cent of pure carbon.

All the air required for furnace combustion is taken from the atmosphere, which consists of a mixture of 1 pound of oxygen to 3.35 pounds of nitrogen; or, by volume, 1 cubic foot of oxygen to 3.76 cubic feet of nitrogen. Nitrogen is an inert, neutral gas that gives no aid in sustaining life or in promoting combustion; but it passes into the furnace with the oxygen, and has to be heated to the same temperature as the other gases.

#### SCIENTIFIC MEASUREMENTS.

In treating of combustion it is constantly necessary to speak of measuring gases by weight. How air and other gases can be weighed as if they were sugar or tea seems a puzzle to many men not acquainted with laboratory work; but they must take it for granted that these things are done.

Before dealing with the action of the air on the fuel resting on the grates, we might mention that scientists have devised a scale of measurement of heat, which is just as necessary for the comprehension of combustion as ordinary weights and measures are for mercantile purposes. The amount of heat necessary to raise the temperature of one pound of water, at its greatest density, one degree Fahrenheit is called a heat-unit, or sometimes a thermal unit. This is equivalent in mechanical energy to the power required for raising

772 pounds one foot high. The enormous amount of mechanical energy present in each pound of good coal will be understood from a small calculation. A pound of good coal properly burned generates about 14,500 heat-units. Then 14,500 multiplied by 772, the number of foot-pounds in each heat-unit, gives 11,194,000 foot-pounds, which is sufficient energy to raise the weight of one ton more than one mile high. Little more than 10 per cent of this energy is ever utilized by being converted into the work of driving machinery.

#### APPLYING THE PRINCIPLES OF COMBUSTION TO A FIRE-BOX.

Having mentioned the leading elements that take part in keeping a fire burning, we will now apply the operation to the work done in the fire-box of a locomotive. Let us take a common form of engine, such as that shown in Fig. 40, page 322, with a fire-box  $72 \times 35$  inches, which makes about 17 square feet of grate area. The engine starts with a fairly heavy train, and has to keep up a running speed of 40 miles an hour. To maintain steam for this work the engine burns 60 pounds of coal per mile, which is equal to 2400 pounds per hour. This requires that about 141 pounds of coal must be burned on each square foot of grate surface every hour, a very rapid rate of combustion, but a rate common enough on many railroads. As shown in the cut referred to, the engine is of the kind most commonly found pulling our passenger

trains, which have no other means of admitting air to the fire except through the ash-pan.

#### HEAT VALUE OF THE PROPER ADMIXTURE OF AIR.

When the air, drawn violently through the grates by the suction of the exhaust, strikes the glowing fuel, the oxygen in the air separates from the nitrogen and combines with the carbon of the coal. It has been mentioned that elements unite in certain fixed proportions. In some cases the same elements will combine in different proportions to form different kinds of products. If the supply of air is so liberal that there is abundance of oxygen for the burning fuel, the carbon will unite in the proportion of 12 parts by weight (one atom) with 32 parts by weight of oxygen (two atoms). This produces carbonic acid, an intensely hot gas, and therefore of great value in steam-making. If, however, the supply of air is restricted and the oxygen scarce, the atom of carbon is contented to grasp one atom of oxygen, and the combination is made at the rate of 12 parts by weight of carbon to 16 parts by weight of oxygen, producing carbonic-oxide gas, which is not nearly so hot as carbonic-acid gas. It makes a very important difference in the economical use of fuel which of these two gases is formed in the fire.

One pound of carbon uniting with oxygen to form carbonic-*acid* gas generates 14,500 units of heat, or sufficient to raise 85 pounds of water from the tank temperature to the boiling-point. On the other hand, when one pound of carbon unites with oxygen to form



carbonic-oxide gas, only 4500 heat-units are generated, or sufficient to raise  $26\frac{1}{2}$  pounds of water from the temperature of the tank to the boiling-point. The same quantity of fuel, it must be remembered, is used in both cases, the only difference being that less oxygen is in the fire mixture.

#### VOLUME OF AIR NEEDED TO FEED A FIRE.

Our engine using 2400 pounds of coal per hour has to burn  $2\frac{1}{2}$  pounds per minute on each square foot of grate. A very large volume of air has to pass through the grates to supply all the oxygen necessary to combine with the quantity of coal mentioned. The combining proportions of carbon and oxygen to form carbonic acid being 12 to 32, the combustion of each pound of carbon requires  $2\frac{2}{3}$  pounds of oxygen. It takes 4.35 pounds of atmospheric air to supply one pound of oxygen; therefore at the least calculation it will take more than  $11\frac{1}{2}$  pounds of air to provide the gas essential to the economical combustion of each pound of coal. But practice has demonstrated that where combustion is rapid the fuel must be saturated with the air that contains the oxygen, bathed in it, as it were; otherwise a large portion of the furnace-gases will pass away uncombined with the element that gives them any heating value. So it is estimated that at least 20 pounds of air must be passed through the grates of a locomotive to supply the oxygen for each pound of coal burned. At this rate our engine must draw in  $20 \times 2\frac{1}{2} = 46.66$  pounds of air per minute through every foot of grate area. One pound of air,

at ordinary temperature and atmospheric pressure, occupies about 13 cubic feet; so it takes over 600 cubic feet of air to pass every minute through each square foot of grate. This volume of air would be sufficient to fill a cylinder  $18 \times 24$  inches nearly one hundred and seventy times. Or, to put it another way, if there were no obstruction to the passage of air through each foot of grate, a trunk of air over 600 feet long has to pass into the fire every minute. As more than half the opening is obstructed by the iron and coal, a column at least 1200 feet long has to be admitted each minute. With some forms of grates the openings are much more restricted, and consequently the inward rush of air must be faster in proportion.

#### VELOCITY OF THE FIRE-GASES.

There are several practical objections to the air blowing through the grates like a hurricane. The high speed of the gases lifts the smaller particles of the fuel and starts them toward the entrance of the flues, helping to begin the action of spark-throwing. Where they find a thin or dead part of the fire, the gases pass in below the igniting-temperature, or tend in spots to reduce the heat below the igniting-point, and go away unconsumed, at the same time making a cold streak in the fire-box, chilling the flues or other surface touched, and starting leaks and cracks. Then the great volume of air has, under ordinary circumstances, to be heated up to the temperature of the fire-box, and a considerable part of the heat produced

from the coal has to be used up doing this before any of it can be utilized in steam-making. When a large volume of gas is employed it must be passed through the furnace and tubes at a high velocity, the result being that there is not sufficient time for the heat to be imparted to the water; consequently the gases pass into the stack at a higher temperature than would be the case if the movement of the gases were slower. One can get a good personal illustration of this by passing his hand through the flame of a gas-burner.

A thoughtless remedy so readily tried with locomotives that do not steam freely is the use of smaller nozzles. That produces bad results in two ways. It causes increased back-pressure in the cylinders through the restrictions put upon the escape of the steam, thus reducing the power that the engine can exert and causing more steam to be used to perform a given measure of work. It also increases the velocity of the fire-gases, with the result that less of the heat is imparted to the water in the boiler.

Our engine is drawing in 600 cubic feet of air per minute through each square foot of grate, that is,  $600 \times 17$  equals 11,200 cubic feet for the whole grate area. The act of combustion is turning 40 pounds of coal per minute into gas, adding about 300 cubic feet more to the volume. This cloud of gas has to pass out through 202 two-inch flues that give a total opening of 485 square inches, equal to 3.36 square feet. The body of gas reduced to this diameter makes a column over 3400 feet long, so it must pass through at a velocity of at least 3400 feet per minute.

## THREATENED LOSS OF HEAT.

From these figures it will be understood that in firing loss of heat is threatened from two opposite directions. If there is not enough air admitted, a gas of inferior heating power will be generated, and a waste of heat will take place equal to the difference between  $26\frac{1}{2}$  pounds of water evaporated by the heat from one pound of coal burned as carbonic oxide, and 85 pounds of water evaporated when the same weight of coal is burned to carbonic-acid gas. If the admission of air is greater than what is necessary, heat will be wasted in proportion to the quantity needed to raise the temperature of the superfluous air up to the heat of the furnace. Those who have noted the difference in the fuel needed to heat a small and a large room thirty or forty degrees may readily understand the quantity of coal that must be wasted raising about 1000 degrees the temperature of the blizzard of extra air that is often passing through the fire-box of a locomotive. Then, as has been mentioned, an extra supply of air causes an increased speed of draft, and this prevents the sheets and flues from abstracting as much heat as they would if the speed of the gases were slower.

## IGNITING-TEMPERATURE OF THE FIRE.

The igniting-temperature of the fire has been repeatedly mentioned. Everybody meets daily with illustrations of the fact that fuel will not burn till it has been raised to a certain heat. If you put a piece

of wood or coal on the fire it remains unchanged for a time till the temperature at which it combines with oxygen is reached, when it begins to burn. The point of heat at which it begins to burn is called the igniting-temperature. Different kinds of fuel have different igniting-points. Coal-gas does not burn below a red heat of iron, and carbon has a still higher igniting-point. If you take a piece of iron, heated dim red, and try to light an illuminating-gas jet with it you will not succeed. Increase the heat till the iron approaches orange color, and it will then light the gas. From this it will be learned that the igniting-temperature of hydrocarbon-gas is about the cherry heat of iron. As the igniting-temperature of carbon is still higher, it will be understood that coal must be kept at a higher temperature still to make it burn.

When wood, coal, or gas will not begin to burn outside till they have been raised to the heat mentioned, it may be readily understood that they will not burn in a locomotive fire-box if they are not up to the igniting-temperature. As the active portion of the fire is constantly distilling gases from the fuel that rise upwards, and require a high temperature for their combustion, it will readily be seen that a great waste of heat must happen when the temperature of any part of the fire-box gets so low that the gases pass away unconsumed. So the fireman ought to make it his business to see that the fuel in any part of the fire-box is not permitted to fall below the temperature of combustion. It may be said or believed that the heat in the fire-box is so high that it is always up to

the igniting-temperature. This would be a mistake. The rush of cold air is so great that a thin part of the fire readily permits air that is not up to the igniting-temperature to pass through, and it chills all the gas it touches. When a heavy charge of coal is thrown into the fire-box, the cold material reduces for a time part of the fire-box below the igniting-temperature, and the gases distilled by the hot fire beneath are ruined by the cold place they have to go through above, and they pass into the flues in the shape of worthless smoke and coal-gas. The fire-box sheets abstract the heat so quickly that waste will occur from the fuel close to the sheets, or the gases passing up beside them, getting below the igniting-temperature, unless the fireman watches to see that a bright fire is kept up in the vicinity of the sheets.

#### BURNING ANTHRACITE COAL.

Thus far we have considered principally the conditions met with in burning carbon alone, such as may be encountered in burning coke, or in the firing of anthracite-coal-burning engines. Anthracite burns more slowly than bituminous coal, and consequently a larger grate area has to be provided in order that sufficient coal may be burned to keep up the steam required. As cylinders of a given size draw from the boiler the same volume of steam per minute, no matter what kind of coal is used, and as soft coal which burns freely produces about the same quantity of steam per pound consumed as anthracite which burns slowly, means must be devised to make the hard-coal-

burning engine consume the same quantity per minute as the other, and no better way has been found than that of making a large fire-box.

Anthracite coal has to be fired to suit the size of the lumps used. If the coal is in coarse lumps weighing in the neighborhood of eight pounds each, a thick fire must be carried, for the lumps lie so open that the air would pass so freely through that it would chill the fire-box. A thin fire of this kind of coal cannot be carried in a locomotive furnace, for the same reason that you cannot keep a fire burning in a small stove with three or four big lumps of hard coal. In firing lump coal of large size, even when a thick fire is carried, constant care has to be exercised to prevent loss of heat from excessive quantities of air passing through holes. There is a constant tendency for air-passages to form close to the sheets, and good firemen provide against this by keeping the fire heavier close to the sheets than at other parts. When too much air is admitted through the fire, the tendency is to reduce parts of the fire-box below the igniting-temperature, with the results already mentioned.

Firing with large lumps is wasteful both with anthracite and bituminous coal.

When the smaller-broken qualities of anthracite coal are used, a very large grate area is necessary, because the fire must be burned thin, and a thin fire will not stand the action of a sharp exhaust unless the blast is divided over a wide area. The man who makes a highly successful fireman with hard coal, whether it be in lumps or of the small quality, is constantly on

the lookout for spots where an oversupply of air is beginning to work through, and he promptly checks this by applying fresh coal at the proper point.

#### BURNING BITUMINOUS COAL.

The burning of bituminous coal is a much more complex operation than that of burning anthracite. The volatile gases in this kind of coal contain great heat-generating power, but they are difficult to burn so that none of the heating elements will be lost. Average bituminous coal contains 65 per cent of carbon and 25 per cent of hydrocarbons. About  $\frac{1}{4}$  by weight of the latter is hydrogen-gas, which makes the hottest fire that can be burned; but it ignites only at a very high temperature, as has been alluded to, and if the fire-box or any part of it gets cooler than this all or a part of the gas passes away unconsumed. In that case there is direct loss by the gas not being used to create heat, and also loss due to the work done by the burning carbon in gasifying the hydrocarbons. To turn a solid into a gas uses up heat in the same way that evaporating water into steam does.

To burn, hydrogen-gas unites in the proportion of two parts by weight (two atoms) to sixteen parts by weight of oxygen (one atom), and the product is water. It may appear strange that water is formed by the burning of a fire; but such is the case, and a tremendous heat is evolved by the operation. The water passes away in the form of colorless steam; but when it touches a cool place the vapor instantly condenses into water. When a fire is newly lighted in



the fire-box of a locomotive the drops of water that may be seen oozing out of the smoke-box joints is the water formed from the hydrogen of the fuel.

#### HEAT VALUE OF THE VOLATILE GASES.

The combustion of each pound of hydrogen-gas, if it combines with eight pounds of oxygen taken from the air, produces about 62,000 heat-units, or enough to raise about 365 pounds of water from the tank temperature to the boiling-point. It will be noted that one pound of hydrogen calls for eight pounds of oxygen (2 to 16) for perfect combustion, while each pound of carbon requires only  $2\frac{1}{3}$  pounds of oxygen (12 to 32). As the hydrocarbon-gases are released at the top of the fire, it is difficult getting this very large volume of air needed for combustion to the proper place, unless means are taken for admitting air above the fire.

Where there is much volatile gas in the coal, it is an economical arrangement to admit air above the fuel; but the means of its admission ought to be under the control of the fireman, or there is likely to be loss of heat by the ingress of cold air when it is not needed.

It is important in the economical combustion of coal to keep the fire as bright on the top as possible. Experimenters on combustion have found that "the efficiency of fuel to heat by radiation depends directly upon the luminosity of the products of combustion." That means that a smoky or cloudy fire wastes a great part of the heat, because the heat rays cannot strike

the heating surfaces. The "luminosity" or brightness of the flames of a fire is said to be due to the free carbon liberated by the hydrocarbons of the flame being heated up to the temperature of the flame itself. The solid particles becoming incandescent act like tiny incandescent gas-lights, each particle of free carbon throwing off heat and light in all directions until consumed and converted into carbonic-acid gas. This free carbon is the last component of the flame to burn, and it only burns at a very high temperature; so if the fire-box is not maintained very hot there will be little bright flame, the volatile gases will pass off as smoke, and those burned will lose part of their value through not being able to send through the mist of smoke their steam-making rays.

#### HEAT LOSSES THAT RESULT FROM BAD FIRING.

Our engine is laboring along with a heavy, thick fire on the grates. The air that passes up into the fire has the atoms of oxygen seized on by the glowing carbon first encountered, and the heat generated keeps distilling the hydrocarbon-gas from the green coal above. There being no means of admitting air above the fire, and there being very little oxygen left in the air after it has worked up through the body of the burning fuel, the volatile gases fail to receive their supply of oxygen, and with their great steam-making possibilities they pass away in the form of worthless smoke and unconsumed coal-gas. The fire being so thick and compact that the air cannot diffuse freely through the mass, a considerable part of the solid carbon does

not receive its full share of oxygen, so it passes away in the inferior heating condition of carbonic oxide.

An inferior fireman, who maintains a thick fire, will often use up an enormous quantity of coal without making an engine steam freely. This is caused by the air failing to reach the 25 per cent of the fuel that exists as hydrocarbons, and which is in consequence utterly wasted; and because part of the solid carbon is burned to carbonic *oxide*, which produces 4500 heat-units, as compared with 14,500 heat-units that would result from the carbon being consumed as carbonic-*acid* gas. A fire run in this wasteful manner is always smoky, and the fire-box looks dull and cloudy, with a tendency for the sheets to hold a covering of soot. Other losses due to a smoky fire have already been explained.

Some firemen have acquired the habit of firing at times when the fire-door ought to be kept closed. As soon as the engineer opens the throttle to pull out of a station these men begin filling up the fire-box. Cold air is pumped through the flues without any need for it, and the charge of fresh coal put in at the wrong time helps add to the chilling effect. When approaching a heavy pull these men generally let the fire get thin, and then they are ready to begin shoveling industriously when the engine is toiling hard up the grade.

#### EFFECT OF SMALL NOZZLES.

Thick, heavy firing, with all the losses described, is not always caused by ignorance or want of skill on the

part of the fireman. It is very frequently the case that an engine will not steam freely unless a heavy fire is carried. This state of things is nearly always due to the use of very small nozzles, which make the blast so sharp that a thin fire could not be used, as the fierce rush of air would be constantly tearing holes in places through which the cold air would pass directly into the flues. When an engine does not steam freely, the tendency always is to call for smaller nozzles; yet it often happens that the nozzles are already too small for free steaming. The diverse character of the coal supplied on most roads is responsible for great waste of fuel. With the average coal an engine will steam while using a large nozzle. But occasionally some cars of coal will be sent in that contains a large percentage of slate and other incombustible material. When an engine gets a tenderful of this stuff, there will be trouble in making steam freely enough to take the train along on time. The men know that a sharp blast would help them in such a case, and it is natural that they should be ready always to provide against this emergency.

#### BOILER-DESIGNING.

The mistakes and prejudices of enginemen often lead to the use of extravagantly small nozzles; but what in most cases makes the use of small nozzles necessary is badly proportioned locomotives. Where the cylinders are too large for the boiler, or where the fire-box is badly proportioned, the defect must be overcome by employing small nozzles.

For burning bituminous coal economically means should be provided for regulating the supply of air above and below the fire, the same to be under control of the fireman. The dampers should also be so constructed that the supply of air through the grates could be regulated to suit the needs of the fire. A light fire could often be carried if the fireman could restrict the air to the exact volume wanted. If greater attention were directed to this part of locomotive construction, firemen would feel more encouraged to find out what supply of air best suited a fire for the economical combustion of coal.

A good brick arch when properly cared for is a very valuable aid to economical combustion. The great mass of hot brick helps to maintain the temperature of the fire-box even, and is often the means of raising gases to the igniting-temperature before they pass into the flues. Projected as it is into the middle of the fire-box, it lengthens the journey of part of the fire-gases and acts as a mixer of the elements that must combine to effect combustion.

## CHAPTER XXII.

### STEAM AND MOTIVE POWER.

IN the previous chapter we have mentioned that the heat value of coal is measured by the number of heat-units it contains, and that each heat-unit represents 772 foot-pounds of work, or the energy required to raise 772 pounds one foot. According to the figures given, each pound of coal contains an enormous amount of possible work energy. The operating of the locomotive, and of all other steam-engines, is a process of transforming the heat energy of coal into mechanical work. In some kinds of engines driven by hot air or gas the operation of converting heat into work is done without the use of steam. A greater proportion of the heat energy can be utilized in that way; but there are mechanical obstacles which prevent such systems from being used where much power is required.

#### CONVENIENCE OF STEAM FOR CONVERTING HEAT INTO WORK.

Steam, the vapor of water, has been found the most convenient medium for transforming the energy of

coal into the useful work of pulling railroad trains, and of driving other kinds of machinery. Water has the greatest heat-absorbing capacity of any known substance, which makes it an excellent means of converting heat into work; but it has some peculiarities which readily lead to great loss of energy if not carefully controlled. If we follow the circle of operations which the burning of coal for steam-making purposes sets going, we shall meet at every move heat losses which show us why so small a portion of the entire heat energy of coal reaches the crank-pins that turn the wheels of the engine. But an intelligent study of the losses will also help an engineer to restrain them to the lowest possible limit.

#### HEAT USED IN EVAPORATING WATER.

Suppose we take one pound of water at a temperature of  $40^{\circ}$  Fahr., and apply heat to it in an open vessel. If we put a thermometer in the water, we shall find that the temperature will rise rapidly till it reaches  $212^{\circ}$ , the boiling-point at the pressure of the atmosphere. Then the mercury stops rising, but the water keeps absorbing the heat and turning into steam. It takes rather more than  $5\frac{1}{2}$  times the quantity of heat to evaporate the whole of the pound of water into steam than it took to raise the temperature from the tank temperature to the boiling-point; for, although it is not shown by the thermometer, the converting of the pound of water from the boiling-point into steam uses up 965.7 heat-units, that being called the latent heat of steam at atmospheric pressure. In raising the

water to the boiling-point—from  $40^{\circ}$  to  $212^{\circ}$ —172 heat-units were used, and in vaporizing the water 965.7 units, making in all 1137.7 heat-units, which are expended in evaporating one pound of water under the pressure of the atmosphere alone, which is 14.7 pounds to the square inch. Steam formed under this light pressure fills 1644 times the space occupied by the water it was made from. The volume of steam varies nearly inversely as the pressure, so that when the steam is generated under the pressure of two atmospheres it fills only 822 times the space that the water did. Every step in the increase of pressure reduces the volume of the steam in like proportion. Steam at 150 pounds per square inch gauge-pressure is only 173 times the volume of the water. Steam gauge-pressure is the pressure above the atmosphere; absolute pressure is reckoned from the vacuum-line.

#### LITTLE EXTRA HEAT NEEDED FOR MAKING HIGH-PRESSURE STEAM.

If the pound of water, instead of being left to boil in an open vessel, had been put into a boiler where a pressure of 165 pounds absolute was put upon it, that being equal to a gauge-pressure of 150 pounds, the result would have been different. When heat was now applied, the mercury would keep rising till the temperature of  $365.7^{\circ}$  was reached before the water would begin to boil. To raise it to the boiling-point under this pressure, 330.4 heat-units would be put in the water, and then the addition of 855.1 more heat-units would convert the whole pound of water into



steam, the total expenditure of heat being 1185.5 heat-units. From this it will be seen that while the generating of steam at atmospheric pressure, which gives no capacity to speak of for doing work, calls for an expenditure of 1137.7 heat-units, raising the steam to the high gauge-pressure of 150 pounds takes only 1185.5 heat-units. Steam of 100 pounds gauge-pressure uses up 1177 heat-units, so that it takes very little more heat to raise the steam to the higher pressure where it has the power of doing much more work than to the lower pressures. A study of these facts will show why it is most economical to use steam of high pressure.

#### CONDITIONS OF STEAM.

Steam formed in ordinary boilers, where only sufficient heat is applied to evaporate the water, is called saturated steam. It is also sometimes spoken of as dry steam or anhydrous steam. Saturated steam contains only just sufficient heat to maintain it in a gaseous condition, and the least abstraction of heat causes a portion of the steam to fall back into water, when it loses its power of doing work. This is why it is important that steam cylinders and passages should be well protected from cold. The condensation of steam that goes on in badly lagged cylinders wastes a great deal of fuel.

When heat is applied to steam that is not in contact with water, the steam absorbs more heat and is said to be superheated. Superheated steam has a greater energy than saturated steam in proportion to

the amount of heat added. The practical advantage of superheated steam is that it does not turn into water in the cylinder so readily as saturated steam.

#### METHODS OF USING STEAM.

Having got steam raised to 150 pounds gauge-pressure, which is almost 165 pounds absolute, the next move is to use it to the best advantage, so that the greatest possible amount of work will be got out of every pound of steam generated. In ordinary circumstances, the higher the temperature of steam admitted into the cylinders of a steam-engine, and the lower the temperature at which it is passed out by the exhaust, the greater will be the economy, if the reduction of temperature has been due to the conversion of heat into mechanical work.

That the steam passed into the cylinders may be used to the best possible advantage, the ordinary practice is to cause the expansive force of the steam to do all the work practicable. As has been already mentioned in a former chapter, high-pressure steam is like a powerful spring put under compression, and is ever ready to stretch out when its force is directed against anything movable. In that way it pushes the piston when the valve is cutting off admission of steam before the end of the stroke is reached. We shall try to show how such practice is economical.

#### THE STEAM-ENGINE INDICATOR.

To find out what is going on in the inside of the cylinders of an engine, to show accurately how the

steam is distributed, the use of the steam-engine indicator is necessary. The indicator consists essentially of a small steam-cylinder, whose under side is con-

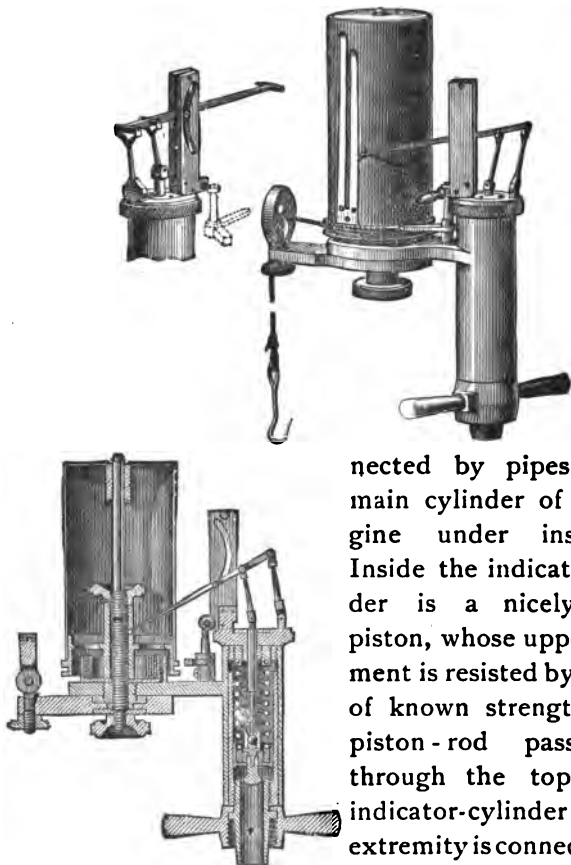

FIG. 44.

ected by pipes to the main cylinder of the engine under inspection. Inside the indicator-cylinder is a nicely fitting piston, whose upper movement is resisted by a spring of known strength. The piston-rod passes up through the top of the indicator-cylinder; and its extremity is connected with mechanism for operating a pencil, and marking on a card a diagram whose lines coincide with the movement of the indicator-piston.

Fig. 44 gives perspective and sectional views of the Tabor indicator, an instrument well adapted for application to locomotives. The card to be marked is fastened in the paper drum attached to the indicator. This drum receives a circular motion from a cord which is operated by the cross-head of the locomotive; and the connection is so arranged that the drum will begin to move round just as the main piston begins its stroke. The circular motion of the drum is continued till the piston reaches the end of its stroke, when the drum reverses its movement, and returns to the exact point from which it started. Now the indicator-cylinder being in communication with the main cylinder, when the latter begins to take steam, the pressure will be applied to the indicator-piston, which was pushed upward, at the same time transmitting its movement to the pencil. The indicator-piston will rise and fall in accordance with the steam-pressure in the cylinder: and the circular movement of the drum coinciding with the cross-head movement, the pencil will describe a diagram which represents the pressure inside the main cylinder at the various points of the stroke.

#### THE INDICATOR-DIAGRAM.

Fig. 45 is a very good diagram taken from a locomotive cutting off at about 37 per cent of the stroke and running at 150 revolutions per minute. *A* is the atmospheric line traced before steam is admitted to the indicator. *V* is the vacuum-line traced according to measurement, 14.7 pounds below the atmospheric line. *DE* is the admission-line, *D* being the point

where the valve opens to admit steam.  $EF$  is the steam-line, beginning at the point of change in direction of the admission-line. The steam-line in this diagram drops down before the point of cut-off is reached, through the steam admission not being rapid enough to keep it up.  $FG$  is the expansion-line traced after the steam is cut off. At the point  $G$  the exhaust takes place, and the exhaust-line is from  $G$  to the end

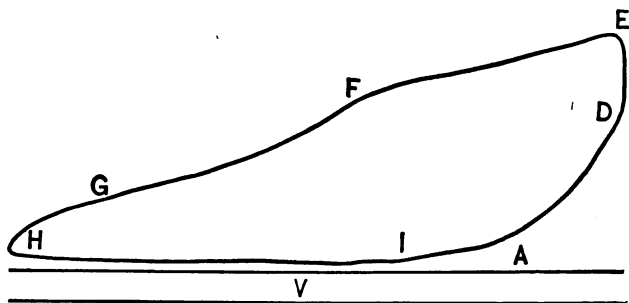

FIG. 45.

of the stroke.  $HI$  is the line of counter-pressure, and is high or low according to the quantity of steam left in the cylinder by the exhaust. The use of small nozzles always causes a high counter-pressure line. The compression-line begins at  $I$ , the point where the valve closes, and runs up to  $D$ , the pressure rising as the steam left in the cylinder, after the valve closes, gets pressed by the piston into small space.

For an exhaustive and easily understood treatise on the indicator our readers are referred to Hemenway's "Indicator Practice and Steam-engine Economy," published by John Wiley and Sons, New York.

PRACTICAL ILLUSTRATION OF STEAM-USING.

Suppose the steam in our boiler is raised to 165 pounds absolute pressure, and we apply it under different conditions to do work in the cylinder *ZZ* shown in Fig. 46, which is 16 inches diameter and has

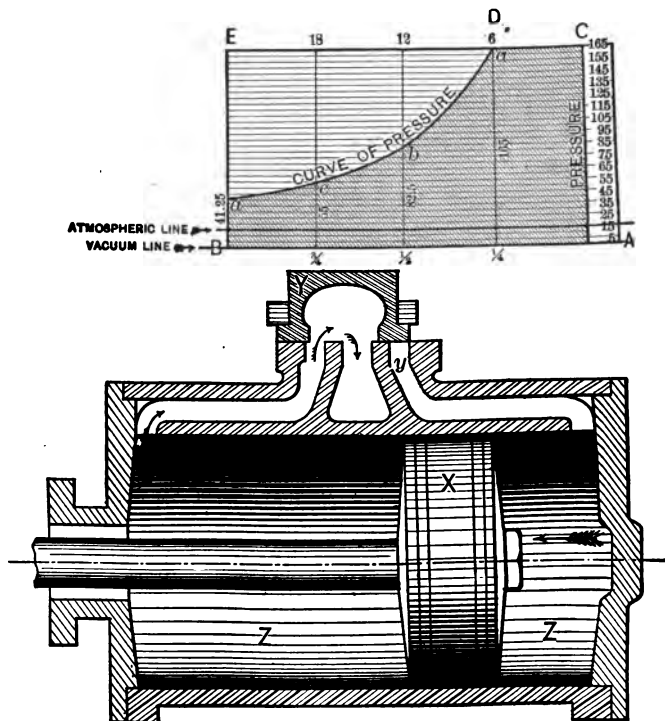

FIG. 46.

a stroke of 24 inches. The diagram above the cylinder represents the action of steam in the cylinder. The vertical lines represent the steam at different

points of the piston's stroke. If the cylinder were filled with steam at boiler-pressure during the entire stroke of the piston, the diagram of work would resemble the rectangle  $ACEB$ . Using the steam in this way is impracticable, but an approximation to it is possible, and it will serve to illustrate the subject. Ignoring the quantity needed to fill the clearance-spaces, the steam from one pound of water, which is called a pound of steam, would just be sufficient to fill the cylinder once.

#### CURVE OF EXPANDING STEAM.

Instead of permitting the steam to follow the piston unimpeded during the whole stroke, we will cut it off at 6 inches or one quarter stroke, as shown in the illustration Fig. 46, where the valve  $Y$  is closing the port  $y$ , just as the piston  $X$  has moved one quarter the stroke. The piston will now be pushed the remainder of the stroke by the expansive force of the steam, the latter falling in pressure as the space to be filled increases, and obeying what is called Mariotte's law, the pressure varying inversely as the volume. By the time the piston has moved to half stroke, the steam is filling twice the space it was in when cut-off took place, and accordingly its pressure has fallen to the point  $b$ , which represents 82.5 pounds to the square inch. At the end of the stroke, when release takes place, the pressure has fallen to 41.25 pounds. We find by calculation that the average pressure on the piston when the steam was cut off at quarter stroke was 98.42 pounds to the square inch. In this case

just one quarter the quantity of steam was drawn from the boiler that was taken when steam followed full stroke, yet with the small quantity of steam the average pressure on the piston was considerably more than half of what it was when four times the volume of steam was used.

The description of the action of the steam does not represent with any degree of accuracy what actually takes place; but it gives the facts closely enough to indicate how steam can be saved or wasted.

#### EFFECTS OF HIGH INITIAL AND LOW TERMINAL PRESSURE.

All engineers who have given the economical use of steam intelligent study agree that the proper way to use steam in a cylinder is to get it in as near boiler-pressure as possible, so that the greatest possible ratio of expansion may be obtained while doing the necessary work. Where this practice is not followed, the steam is used wastefully. Locomotives that are run with the throttle partly closed, when by notching the links back it could be used full open, are throwing away part of the fuel-saving advantages that high pressure offers.

For this practice the engineers are not in every case to blame, for many locomotives are constructed with valve motion so imperfectly designed that the engines will not run freely when they are linked close up. With the small nozzles made necessary to force the steam-making in small boilers, the back cylinder-pressure is so great that the high compression, resulting



from an early valve-closure, prevents the engine from running at the speed required.

From whatever cause it originates, the practice of running with the throttle partly closed causes much waste of fuel. A few examples will be given:

The diagram shown in Fig. 47 was taken from a locomotive running at 192 revolutions per minute. The boiler-pressure was 145 pounds, and the initial pressure on this card is 136 pounds. This high cylinder-pressure was obtained by keeping the throttle-valve full open. The driving-wheels were 68 inches diameter, and the engine was running close on forty

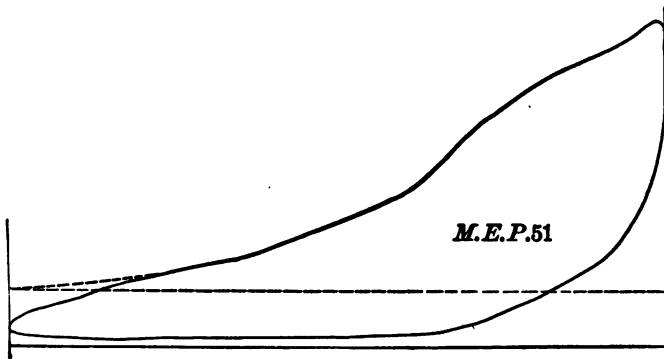

FIG. 47.

miles an hour and was developing, with 18×24-inch cylinders, sufficient power to haul a train weighing 300 tons at the rate of fifty miles an hour. Steam was cut off at about seven inches of the stroke, expanded down to 25 pounds above the atmospheric line, and showed an average back-pressure of 4 pounds. The

work was done using at the rate of 21.5 pounds per horse-power per hour—very economical work.

Diagram Fig. 48 shows about the same power as the other one; but it was taken with the steam partly throttled, and cutting off at  $10\frac{1}{2}$  inches. In this case it will be noted that the initial pressure is only 102 pounds, that the terminal pressure is 31 pounds above the atmosphere, and that the counter-pressure is 7 pounds. In this case the work is done by using steam

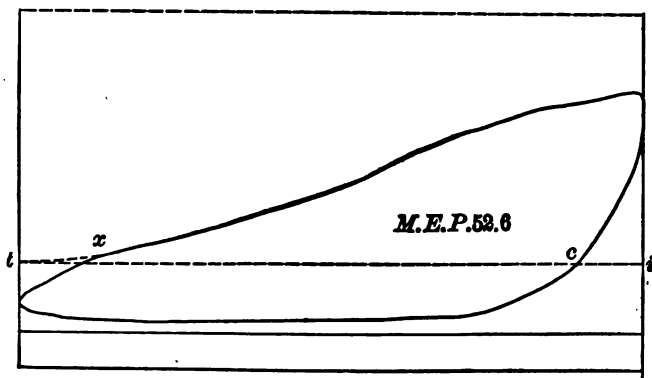

FIG. 48.

at the rate of 25.8 pounds per horse-power per hour, which is 16.6 per cent more steam than was used with the other way of working. There was no reason whatever for working the engine in this manner, except the careless practice that some runners get into.

A still worse case is shown by the diagram Fig. 49. Here the engine, which was running at 176 revolutions per minute, was worked cutting off at half stroke, and the average steam-pressure kept down by throttling.

Consequently the initial pressure is low, the terminal pressure and the back-pressure high. This condition of working calls for the use of a large volume of steam to perform the work. The initial pressure is 109 pounds, the terminal pressure 45 pounds, and the back-pressure 11 pounds. The engine while working this way used steam at the rate of 32 pounds per horse-power per hour, or 33 per cent more than was used in the first case. These are examples taken from

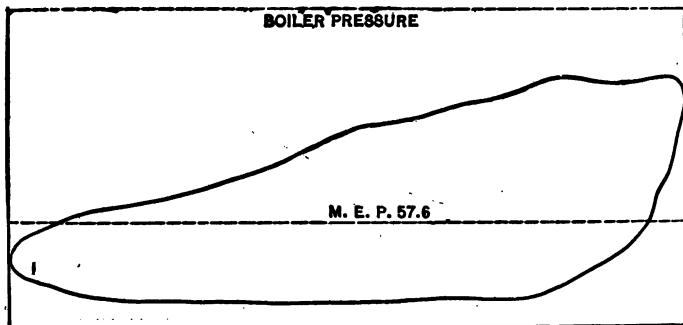

FIG. 49.

the ordinary working of locomotives. They are no mere theories. They are the record of accurate measurements and are as trustworthy as the indications of the steam-gauge. Using 33 per cent more steam than what is absolutely necessary is just throwing away one-third of the coal put into the fire-box.

To put the matter in a more concrete form: If the engine from which diagram Fig. 47 was taken was running 33.3 miles to the ton of coal, only 27.7 miles to the ton would be made when using the steam shown

in diagram Fig. 48 and only 22.3 miles when diagram Fig. 49 was the record of the steam consumed.

#### COMPOUND LOCOMOTIVES.

There are some disadvantages to working with wide extremes of pressure in a cylinder. The temperature tends to change with changes of pressure, and this leads to loss through condensation of the steam in the cylinder. In the working of the simple engine we have been dealing with, where steam of 165 pounds absolute pressure was used, the steam enters the cylinder at about 365° Fahr., and escapes close to atmospheric pressure at a temperature of about 220°. The metal of the cylinder inclines to maintain an even temperature at some average point between the high admission and the low exhaust temperatures. When the steam enters the cylinder it goes into a comparatively cool chamber, and the metal of the cylinder walls and heads draws some heat from the incoming steam. The portion of the steam robbed of its heat becomes spray, and helps to dampen the steam that continues to pass into the cylinder. As the events of the stroke go on, and release of pressure takes place after the opening of the exhaust-port, the steam which became condensed in the beginning of the stroke is ready to flash back into steam under the release of pressure. If this happens as the steam is passing into the exhaust-port, it draws heat from the cylinder-metal to aid in the act of vaporization, the whole of this heat being carried up the chimney. The heat thus carried away from the cylinder-metal has to

be returned by the incoming steam of next stroke, and causes the initial condensation spoken of. Compression helps to prevent condensation by heating the cylinder at the end where steam is about to enter.

Another disadvantage of the locomotive cylinder is that the opportunities for using the steam expansively are very limited.

To provide a remedy for the losses due to cylinder condensation, and to provide better means of using the steam expansively, compound locomotives have been brought into use. A compound locomotive, while expanding the steam more than can be done with a simple engine, has a much more even temperature throughout the two strokes in which the steam is used. If there is condensation and revaporization of steam in the high-pressure cylinder, it passes into the low-pressure cylinder and is there used to do useful work. In a compound engine the work is more evenly distributed throughout the stroke than in a simple engine, consequently the strains and shocks given to the machinery are less. This ought to make the compound a durable machine.

## CHAPTER XXIII.

### SIGHT-FEED LUBRICATORS.

THE introduction of sight-feed lubricators for oiling the valves and pistons of locomotives is one of the most important improvements carried out in the last quarter of the nineteenth century.

#### EARLY METHODS OF STEAM-CHEST LUBRICATION.

When locomotives were first put into service it was supposed that the low-pressed steam employed would supply sufficient moisture to lubricate the rubbing surfaces and prevent cutting. That plan did not work long and oil-cups were put on the steam-chests. A decided improvement on the steam-chest cup was the placing of oil-cups in the cab, with pipes to lead the lubricant to the steam-chest.

All those mentioned were crude methods at the best. The sight-feed lubricator was introduced in the progress of improvement, and appealed so strongly to those who appreciated the lubrication requirements of slide-valves and pistons that it soon became a recognized necessity of a properly equipped locomotive.

For several years the merits of the sight-feed lubricator for locomotives were more apparent than real.

One watching the regulated number of oil-drops passing each minute from the lubricator into the oil-pipe naturally supposed that the same number of drops were passing with the same regularity into the steam-chest.

#### MISTAKES ABOUT ACTION OF SIGHT LUBRICATORS.

There is now reason for believing that a great part of the time the oil kept dropping into the oil-pipes, which acted as reservoirs, until a reduction of steam in the steam-chest permitted the steam passing through the lubricator to overcome the pressure in the steam-chest and force the oil into that chest.

The principle of the sight-feed lubricator is that water condensed from a steam connection with the boiler passes below a body of oil standing in the oil-chamber, and owing to the lighter specific gravity of the oil pushes out a drop of oil for every drop of water that passes into the chamber. The water being heavier than oil, naturally keeps the body of oil floating upon it. The oil that is forced towards the oil pipes has behind it the pressure due to the steam connection with the boiler, and it was assumed that the boiler pressure through the lubricator would always be sufficient to overcome the steam-chest pressure. In practice, however, it became known that the steam direct from the boiler operating the lubricator was sometimes so reduced in pressure, through restricted passages and other causes, that the steam in the steam-chest opposed the flow of oil, and pushed it upwards from the steam-chest instead of permitting it to pursue its course. This defect did not become very apparent until ex-

treme steam boiler-pressure became common practice. Several special devices have been perfected to overcome this difficulty, particulars of which will be given later.

#### THE NATHAN AND THE DETROIT LUBRICATORS.

There are many kinds of sight-feed lubricators in use for different kinds of engines; but for locomotives there are only two varieties, the Nathan and the Detroit, which are well known. Both these lubricators use the Gates invention of the up-feed of a drop of oil rising through a glass tube of water by virtue of its lighter gravity.

Both these lubricators feed oil to the valves and pistons whether the engine is using steam or not. Both require about the same handling to be successfully operated, and I shall ignore all other makes and consider only these two.

#### LOCATION.

The best location of the lubricator to secure satisfactory results, will largely depend upon the style of boiler and the location of cab-fittings. On engines with large foot plates the best location is over the middle of end of boiler. In this position feeds are in plain view of both enginemen, and irregular working or stoppage will be noticed at once upon engines where the boiler extends well into or through the cab; or with Colburn boilers, where the cab is ahead of the fire-box, the lubricator should be placed with the cylinder feed-glasses in line lengthwise with the boiler



and air-pump, feed- and oil-glass facing the engineer. The bracket supporting the lubricator should be sufficiently heavy to prevent vibration.

#### STEAM-SUPPLY AND PIPING.

The early practice was to connect the steam-pipe of the lubricator to the turret, when one was used. It is now admitted that a better plan is to make an independent connection with the boiler for the lubricator steam-pipe. The favorite plan now is to connect the steam-pipe with the top of the boiler and to make it not less than  $\frac{1}{2}$  inch inside diameter.

#### NATHAN'S TRIPLE-FEED LUBRICATOR.

An elevation view of the Nathan Triple-sight Feed Lubricator, known as Class Bull's-eye type, No. 9, is shown in Fig. 50, and below are the names of the different parts.

<i>A</i> , Filling-plug.	<i>CCC</i> , Regulating-valves.
<i>D</i> , Water-valve.	<i>G</i> , Gauge-glass.
<i>OO</i> , Hand-oilers.	<i>R</i> , Reserve glass.
<i>SSS</i> , Sight-feed drain-valve.	<i>W</i> , Waste-cock.

#### DIRECTIONS FOR APPLICATION.

Secure the lubricator to boiler-head or top of boiler, in the usual manner.

Connect for steam to fountain or turret, if large enough,

otherwise direct to boiler. The steam-pipe must not have less than  $\frac{3}{4}$  inch I. D. when iron pipe is used, and not less than  $\frac{5}{8}$  inch I. D. when copper pipe is used. Steam-valves and their shanks must have openings fully in accordance with these dimensions.

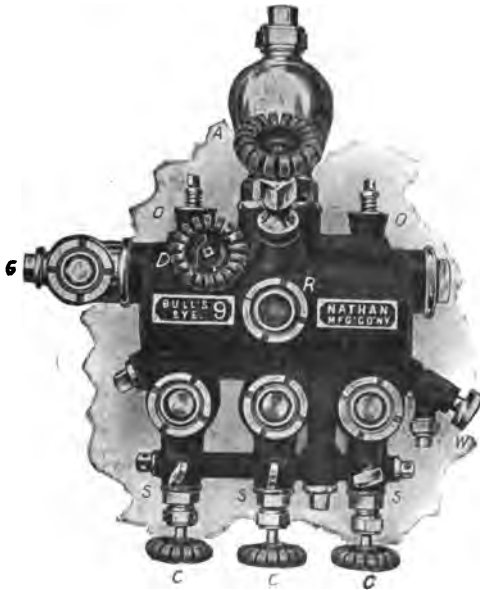

FIG. 50.

Oil-pipes must have a continuous fall towards the steam-chest, without any "pockets" in them.

## DIRECTIONS FOR USE.

Fill the cup with clear, strained oil through filling plug *A*, and immediately after filling, open water-valve *D*. Open steam-valve (not shown), wait until sight-feed chambers are filled with water, then start and regulate the feed by opening regulating-valves *C* more or less, according to the feed desired.

*To Stop Either of the Feeds.*—Close the respective regulating-valve *C*.

## GENERAL REMARKS ON LOCOMOTIVE LUBRICATORS.

The proper manner of applying and operating locomotive lubricators, in a general way so well understood, that when applied and operated in accordance with this general understanding, they perform their functions in most cases in a satisfactory manner. Nevertheless I do not consider it out of place to enumerate a few brief points, which users of lubricators should keep in mind.

*Steam-pipes.*—Before connecting the steam-pipe to the lubricator, especially when it is an iron pipe, it should be blown out thoroughly, to prevent scale and chips from being blown into the lubricator and there to clog up the pipes and other passages.

*Sizes of Steam-pipes* must not be less than called for in the "directions for application."

*Steam-valves* used in connection with lubricators must have openings fully in accordance with the sizes of



pipes. Pipes of proper size, and steam-valves with improper openings in the valve-seat or in the shank, will not work well together.

Steam should be taken from highest part of boiler, and at a point where dry steam may be obtained, using (when necessary) a dry pipe for the purpose. Turrets or fountains are often not large enough to supply all drains made upon them. Do not allow muddy water to get into the lubricator. It will clog the passages, and cut the valve-seats, causing them to leak.

*Oil-pipes* must have a good steady fall from lubricator toward the steam-chest, to prevent the forming of water-traps. Oil will float upward through water but not downward.

*Irregularity* in the feed of lubricators is usually due to enlarged openings in the choke-plugs. The remedy for this trouble is to use choke-plugs of standard size, and to remove them as soon as they fail to maintain the regularity of the feed.

The restriction of the live-steam supply to the lubricator may also cause irregular feeding. Have the steam-valve wide open. If there is reason to suspect a restricted steam-supply from other causes, examine the steam-pipe, equalizing tubes, and equalizing steam passages for stoppages from scale, torn gaskets, etc.

*Filling.*—The greatest care should be exercised in the filling of the lubricator, to prevent foreign matter of any kind from passing into the lubricator with the oil. To prevent this the oil should be thoroughly strained before using it.

*Cleaning.*—In cleaning out lubricators it will be necessary to occasionally immerse them in a lye bath. Some grades of oils leave a residue behind which, under high temperature, seems to “bake” into a hard, gummy scale,

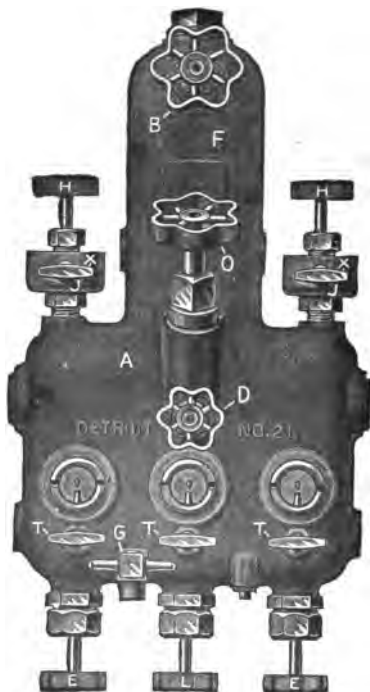

FIG. 51.—DETROIT TRIPPLE-FEED LUBRICATOR.

that cannot be removed by blowing steam through the passages. Strong soap water will sometimes dissolve this gum, and tend to keep the glasses clean.

*Feed-nozzles Stopped Up.*—In this case close the water-valve and all regulating-valves, with the exception of the defective one, which should be opened wide. Open the waste cock at the bottom of the lubricator. With the steam-valve open, the contents of the glass and the obstruction will be blown into the cup and out through the waste cock.

*Choke-plugs Stopped Up.*—Proceed as when cleaning feed-nozzles, and in addition close the steam-valve of the lubricator, and open throttle-valve of engine. This will blow steam from the steam-chest back through the choke-plugs, and blow the obstruction into the sight-chamber and leave the choke passage free.

*Disappearance of Oil from Reservoir.*—This may be caused: 1. By the water-pipe (leading from the condenser to the oil-reservoir) becoming split or loose. 2. By cracks developing in the passages, near the top of the oil-reservoir, allowing oil to feed directly into the delivery arms or into the condenser and from there (through the equalizing pipe) into the tallow-pipes without passing visibly through the glasses. Such defects may develop through careless handling or from freezing.

#### DETROIT TRIPLE-FEED LUBRICATOR.

The purpose of the Detroit Lubricator Company in developing the sight-feed lubricators that eventuated in the bull's-eye pattern, was to produce one in which the sight-feed glass would not break under any circumstances. This aim being reached all danger, delay arising from the bursting of lubricator glasses, have been removed.

The different parts of Detroit No. 21, triple-feed lubricator shown in our engraving are:

- F*, Condenser.
- A*, Oil-reservoir.
- O*, Filler-plug.
- G*, Drain-valve.
- TTT*, Sight-feed drain stems.
- D*, Water-feed valve.
- B*, Steam-valve.
- EE*, Feed-regulating valves to right and left-hand cylinders.
- L*, Feed-regulating valve to air-pump.
- WW*, Coupling to right- and left-hand cylinders.
- R*, Coupling to air-pump.
- C*, Steam connection.
- JJ*, Auxiliary oilers.

#### DIRECTIONS FOR OPERATING.

Steam for lubricator should be taken from turret if large enough, or from dome through an independent dry pipe of 1-inch iron pipe size or its equivalent.

When the lubricator is first applied, blow out thoroughly, then close all the valves.

*To Fill.*—Remove filter-plug *O* and fill the reservoir with clean, strained oil.

*Note.*—If there is not sufficient oil to do so, always use water to make up the required quantity. This will enable the feeds to start promptly.

*Steam-valve.*—The regular boiler-valve should be left wide open, and the steam-valve *B* at top of condenser

must also be kept wide open while the locomotive is in service.

*To Start Lubricator.*—1. Be sure that the regular boiler-valve is open. Then open steam-valve *B* at top of condenser wide open and keep wide open while lubricator is in operation. Allow sufficient time for condenser and sight-feed glasses to fill with water. 2. Open water-valve *D*. 3. Regulate flow of oil to right and left cylinders by valves *EE* and to air-pump by valve *L*.

*To Operate Auxiliary Oilers.*—See that valve *H* is closed. Then open valve *X* and fill body of oiler. Close *X* after filling open valve *H*.

*To Re-fill.*—Always close valves *EE* and *L* in advance of valve *D*. Open drain-plug *G*, then filler-plug *O*. Re-fill and proceed as before.

If at any time it becomes necessary to fill the lubricator with cold oil and the engine will remain out of service for some hours, do not fail to turn on slight steam pressure from the boiler and open valve *D* in order to prevent excessive pressure from expansion of the oil.

*Blowing Out.*—Blow out lubricator once a week or oftener if necessary.

*Getting New or Re-built Locomotive Ready for Service.*—In getting a new or re-built locomotive ready for service, disconnect oil-pipes at steam-chest, and blow out thoroughly both oil-pipes and automatic steam-chest valves; also disconnect coupling to air-pump and see that choke is free. Do this several times while getting the engine ready for service.



## MICHIGAN BULL'S-EYE LUBRICATOR.

The Michigan Lubricator Company of Detroit whose well known bull's-eye lubricator is here illustrated, have introduced a useful addition to the apparatus. It is extremely simple both in construction and operation, consisting merely of a ball float working freely in a



FIG. 52.

cage. The float is so made that it rises and falls with the water level in the lubricator cup or reservoir, always remaining below the level of the oil, but at the surface of the water when the reservoir contains both oil and water, as it usually does.

## CHAPTER XXIV.

### EXAMINATION OF ENGINEERS FOR PROMOTION.

#### FROM WHENCE THEY CAME.

THIS catechism for the examination of engineers and firemen to test their knowledge of their business, has been expanded from a catechism prepared for the use of officials on what is known as the Vanderbilt or New York Central Lines. The railroad officials provided the men to be examined with a list of the questions; we have worked out the answers, and added other questions and answers that are of general interest.

We advise men studying this catechism to refrain from committing the answers to memory, but to acquire the sense of the answers and to use the actual locomotive as an aid to acquiring the desired knowledge.

These questions and answers have been worked up from a code prepared by the Traveling Engineers' Association, and developed by various writers on railroad machinery matters to suit changes in rolling stock and conditions of operating.

## SECTION I.

## FIRST YEAR EXAMINATION.

*General Questions.*

Q. 1. Do you consider it essential to your success in business to abstain from the use of intoxicating liquors? Do you consider it to your interest to work to the best of your ability for the interest of your employer, and be economical in the use of fuel and supplies?

A. This question will be answered according to the judgment of the man under examination.

## DUTIES OF FIREMEN.

Q. 2. What are the fireman's duties on arrival at engine-house previous to going out on a locomotive?

A. See that the fire is in the condition to make up a proper one for starting. See that the ash-pan is clean. Ascertain that the engine has got on all the necessary tools and supplies, and that the engineer's oil-cans are filled.

Q. 3. Is it your duty to compare time with your engineer, and should you insist on seeing all train orders?

A. I should consider it my duty to compare time with the engineer and insist on seeing the train orders, if that was the rule of the company I was working for.

Q. 4. Give the substance of the various rules pertaining to signals as found in the Book of Rules and Regulations of the operating department.

A. This question will be answered by describing the signals described in the book of rules. The meaning of

swinging-arms and lanterns in different ways must be explained, and also the meaning that the rules attach to the station signals used by the road.

Q. 5. In addition to any that you have not mentioned, what else do you consider a danger signal?

A. Any person near the track violently waving his arms or any sort of light would be regarded as a danger signal; also a fire burning on the track.

#### THE STEAM-GAUGE.

Q. 6. Explain the principle of the steam-gauge,

A. There are several kinds of steam gauges, but all of them are operated on one of two principles. When internal pressure is applied to a bent flat tube, the tendency of the tube is to straighten out. That tendency is made use of in the Bourdon gauge, the necessary mechanism for operating the dial needle being connected with the tube. The other form of gauge is operated by a double diaphragm of corrugated plate. When pressure is admitted between the plates it forces them outward and the attachments operate the mechanism that moves the gauge needle.

Q. 7. What pressure is indicated by the steam-gauge? What is meant by atmospheric pressure?

A. The pressure above the atmospheric pressure. The pressure of the atmosphere is that imposed by the body of air surrounding the earth. At sea-level it is 14.7 pounds to the square inch.

## HEAT AND STEAM.

Q. 8. What is the source of power in a steam-locomotive?

A. Steam generated by heat.

Q. 9. What quantity of water ought to be evaporated in a locomotive boiler to the pound of coal?

A. From 7 to 10 pounds. It is seldom more than 5 pounds.

Q. 10. What is steam, and how is it generated?

A. The vapor of water. It is generated by the heat from the fuel burning in the fire-box.

Q. 11. At what temperature does water boil?

A. On the level of the sea it boils at 212 degrees F.

Q. 12. What is the temperature of the water in the boiler when the pressure is 200 pounds?

A. At 200 pounds gauge-pressure the temperature of the water is 387.7 degrees F.

## COMBUSTION AND FIRING.

Q. 13. What is combustion?

A. The chemical combination of the carbon in fuel with oxygen.

Q. 14. What is the composition of bituminous coal?

A. A good quality of bituminous coal contains about 61 per cent fixed carbon, about 31 per cent of volatile matter, known as hydrocarbons, 7 per cent of ash, and 1 per cent of sulphur.

Q. 15. What is carbon? From what is oxygen obtained?

A. Carbon is one of Nature's elements. Nearly all

combustible material, such as wood and coal, consists principally of carbon. Oxygen for sustaining combustion is obtained from the air.

Q. 16. What per cent of oxygen is in the air?

A. The atmosphere contains 20.63 per cent of oxygen.

Q. 17. Is air necessary for combustion?

A. It is.

Q. 18. About how many cubic feet of air are necessary for the combustion of a pound of coal in a locomotive fire-box?

A. It takes 2.66 pounds of oxygen to burn 1 pound of coal into carbon dioxide. It takes 4.35 pounds of air to supply 1 pound of oxygen, therefore it will take  $11\frac{1}{2}$  pounds of air to provide the oxygen necessary to burn each pound of coal. As some excess of air is necessary, 20 pounds of air should be admitted to the fire for each pound of coal to be burned. One pound of air fills about 13 cubic feet at ordinary temperatures, so we have  $13 \times 20 = 260$ , equal to 260 cubic feet of air needed for every pound of coal burned.

Q. 19. How many cubic feet of air, therefore, would be necessary for the burning of a "fire" of four scoopfuls, assuming each scoopful to weigh 10 pounds?

A. For four scoopfuls of coal, each weighing 10 pounds, the quantity of air required for combustion would be  $40 \times 260 = 10,400$  cubic feet.

Q. 20. Why is it necessary to provide for combustion a supply of air through the fuel in the furnace?

A. Because it is only by forcing the air through the burning fuel that the proper mixture of the gases will be effected.

Q. 21. How can you prove that it is necessary to supply air to the fire-box for combustion?

A. By shutting off the air supply.

Q. 22. What is the effect on combustion if too little air is supplied through the fire? If too much air is supplied?

A. If too little air is supplied the fire loses activity and combustion produces carbon monoxide, a gas with only about one-third the heating properties of carbon dioxide, the gas formed when the supply of air is sufficient.

If too much air is supplied waste is caused by heating the surplus quantity of air, and the oversupplying tends to depress the fire-box gases below the igniting temperature.

Q. 23. What effect on combustion has the closing and opening of dampers?

A. A closing of the dampers cuts off the supply of air and prevents the fire from receiving its proper supply of air. Opening the dampers permits the air to pass through the grates. Under some circumstances it is better to keep one damper closed, unless the engine is working very hard.

Q. 24. How is draft created through the fire?

A. By the current of air induced by the exhaust through the flues and smoke-stack.

Q. 25. Describe a blower and its use and abuse.

A. A blower is a jet of steam passed up the smoke-stack to induce an artificial current of air. Its proper use is to prevent smoke when an engine is not working, to draw the fire gases away so that they do not pass into the cab, and to stimulate the fire when necessary.

The abuse of the blower is drawing cold air through the tubes or by forcing the fire when it is not necessary, causing waste of steam through the safety-valves.

Q. 26. What effect is produced by opening the fire-door when the engine is being worked?

A. It cools the boiler and prevents the rapid generation of steam.

Q. 27. What bad effect?

A. It causes sudden contraction of the fire-box sheets and flues, tending to cause leakage.

Q. 28. In what condition, therefore, should the fire be in order that the best results may be obtained from the combustion of the coal?

A. The fire ought to be maintained in the condition necessary to generate the steam required for the way the engine has to be worked. Even firing and even temperature go together.

Q. 29. What is the effect of putting too many scoops of coal on a bright fire? Is this a waste of fuel?

A. Throwing too much coal into a fire at one time depresses the temperature below the igniting-point and causes the generation of smoke. The practice is wasteful of fuel.

Q. 31. What effect has the fire upon a scoopful of coal when it is placed in the fire-box?

A. It distills the volatile gases first, then ignites the carbon of the coal.

Q. 31. In what condition should the fire be to consume these gases?

A. Bright and at a high temperature.



Q. 32. What is the temperature of the fire when in this condition?

A. About 3000 degrees F.

Q. 33. How can the fire be maintained in this condition?

A. By regular firing. That is, by keeping up the supply of fuel as nearly as possible at the rate it is burned.

Q. 34. What is black smoke? Is it combustible?

A. It is unconsumed coal and can be prevented by good firing, if the coal is not too volatile, or the boiler forced beyond the limit where the gases can be properly mixed. It is combustible when mixed with air and kept at a high temperature.

Q. 35. Have you made any effort to produce smokeless firing?

A. Certainly I have.

Q. 36. How can black smoke be avoided?

A. By careful firing. With some qualities of coal and a plain fire-box smoke cannot be entirely prevented.

Q. 37. Can the firing be done more intelligently if the water level is observed closely? Why?

A. Because regular boiler feeding and regular firing go together. The fireman can work more intelligently when he knows that the boiler is being fed regularly.

Q. 38. What advantage is it to the fireman to know the grades of the road and the location of the stations?

A. This knowledge enables him to regulate the firing to suit the fluctuating work the engine will have to do.

Q. 39. How should the fire and water be managed in starting from a terminal or other station?

A. The fire ought to be made up sufficiently heavy

to preclude the necessity for firing while passing through the yards. The boiler ought to be as full of water as can be carried without priming.

Q. 40. What is the purpose of a safety-valve on a locomotive boiler? Why is more than one used?

A. To relieve the boiler from over-pressure of steam. Two safety-valves are used because one is sometimes unequal to the task of preventing over-pressure.

Q. 41. What usually is the cause for steam being wasted from the safety-valve?

A. Injudicious firing, or want of co-operation between engineer and fireman.

It is frequently due to want of co-operation between the people who regulate the movement of trains and the enginemen.

Q. 42. What is the estimated waste of coal for each minute the safety-valve is open?

A. From 15 to 20 pounds.

A systematic test was made of an engine with about 1200 square feet of heating-surface and 27 square feet of grate area to ascertain the volume of steam wasted through the safety-valve. It was found to be 91 lbs. of water per minute. As each pound of coal burned will evaporate about 6 lbs. of water, the waste of coal in that case would be about 15 lbs. per minute.

Q. 43. What should be done to prevent waste of steam through the safety-valves?

A. The firing should be so regulated when the engine is working that the steam will not rise to the blowing-off point; when steam has to be shut off unexpectedly blowing-off may be prevented by closing the dampers,

opening the fire-box door a little and keeping the injector going. The surplus steam may also be blown back into the water-tank.

Q. 44. What should be the condition of the fire on arriving at a station where a stop is to be made?

A. Bright and clear, so that little smoke will flow from the stack. There must be sufficient fire on the grates to build on when the engine is started.

Q. 45. How should you build up the fire when at stations in order to avoid black smoke?

A. By putting in small quantities of coal at a time at short intervals and permitting the charges to burn bright.

Q. 46. What should be the condition of the fire when passing over the summit of a long grade?

A. It should be burned down as low as the requirements of steam-making will permit.

Q. 47. If the injector is to be used after passing over summit, how should the fire be maintained?

A. The fire ought to be maintained bright and the blower kept in use to create some circulation of the water of the boiler.

Q. 48. Is it advisable to take advantage of every opportunity to store in the boiler as much water as possible?

A. It is.

Q. 49. Why is it that if there is a thin fire with a hole in it, the steam pressure will fall at once?

A. Because cold air passes through the hole and has a chilling effect upon the boiler.

Q. 50. What would be the result of starting a heavy train with too thin a fire upon the grates?

A. Delay for want of steam.

Q. 51. How deep a fire should be carried?

A. It should be no deeper than necessary to make the required steam. The kind of fire-box and the work to be done would influence the proper depth of fire.

Q. 52. Where should the coal, as a rule, be placed in the fire-box?

A. It ought to be placed evenly over the entire surface of the grates.

Q. 53. Is rapid firing advisable?

A. No. Not the rapid firing that puts a heavy charge of fresh coal quickly into the fire-box. The rapid action that puts a scoopful of coal where it belongs, having the door open as short a time as possible, is commendable.

Q. 54. When and for what purpose is the use of rake on the fire-bed allowable?

A. When the surface of the fire is coking so that combustion is obstructed.

Q. 55. Within what limits may steam pressure be allowed to vary, and why?

A. When an engine is working the steam pressure ought to be kept as uniform as possible short of blowing-off pressure. When approaching stations the steam pressure should be reduced sufficiently to prevent blowing-off.

Q. 56. Is it advisable to raise steam rapidly?

A. Not if it can be avoided without causing delay. Rapid raising of steam, especially from cold water, puts destructive strains upon the boiler sheets.

Q. 57. Has improper firing any tendency to cause tubes to leak? How?

A. It has. Improper firing causes wide variations in the temperature of the fire-box, and sudden reduction of temperature causes the tubes to contract and leak.

Q. 58. What would you consider abuse of a boiler?

A. Intermittent firing, causing fluctuating variations of fire-box temperature, cooling by means of an open fire-box door and intermittent boiler feeding. Feeding the boiler rapidly when steam is shut off abuses the boiler.

Q. 59. How would you take care of a boiler with leaky tubes or fire-box?

A. Maintain the temperature as evenly as possible by uniform firing and boiler feeding. I should avoid feeding when steam was shut off.

Q. 60. What are the advantages of an arch in the locomotive fire-box?

A. It tends to keep the temperature of the fire-box uniform; it prevents cold air from passing directly into the tubes, and it lengthens the journey of the fire gases on their way to the tubes. The arch acts also to some extent as a spark-arrester.

Q. 61. Why is it very important that coal should be broken so that it will not be larger than an ordinary sized apple before being put into the fire-box?

A. Because in that condition it provides the best surface for ignition and provides the proper openings for emission and mixture of the fuel gases.

Q. 62. When and why should you wet the coal in the tender?

A. As soon as the supply of coal has been put upon the tender. The wetting is done to keep down the dust.

It also tends to keep the mass of fine coal together and prevents it from being drawn into the tubes by the suction of the exhaust.

Q. 63. Should coal be allowed to lie on the deck and fall out of the gangway?

A. Certainly not.

Q. 64. Do you understand that the coal used on the locomotive is property and represents money invested by the company?

A. I do.

Q. 65. What are the advantages of a large grate surface?

A. It permits of slower combustion than would be practicable with smaller grate surface, and slow combustion under proper restrictions promotes economy of fuel.

Q. 66. Why are the grates made to shake, and when should they be shaken?

A. To break up the clinkers and ashes that close up the grate openings and restrict the supply of air. The grates should be shaken very lightly as soon as the fire shows that the air is too much restricted. With some kinds of coal the grates must be moved frequently to prevent them from "sticking," a condition caused by fused clinker.

Q. 67. Why should grates not be shaken too frequently?

A. Because good fuel would be wasted and the ash pan prematurely filled, with danger of burning grates.

Q. 68. Is it a fireman's duty to avoid filling up the ashpan too full?

A. Certainly it is.

Q. 69. Is it permissible to dump ashes or fire over road crossings, switches, or around stations?

A. It is not.

Q. 70. Is it objectionable to fill the tanks too full or spill water at stand-pipes or water-tanks?

A. It is a very objectionable and dangerous practice, and should be avoided.

Q. 71. What are the duties of a fireman on arriving at a terminal?

A. The answer to this question will vary according to the rules of the particular road.

Q. 72. Is the engineer responsible for the fireman's conduct while on duty and the manner in which the fireman's duties are performed?

A. He is.

#### AIR-BRAKE QUESTIONS AND ANSWERS,

##### FIRST YEAR EXAMINATION.

Q. 1. What is an air-brake?

A. It is a brake operated by compressed air, and requires special mechanism for the application of the power.

Q. 2. How is the air compressed for use in the brake system?

A. By means of an air-pump, or compressor, located at some convenient place on the side of the locomotive boiler.

Q. 3. What are the essential parts of the air-brake as applied to a locomotive?

A. They are an air-pump or compressor, an air-pump governor, a main reservoir, an engineer's brake, and equalizing discharge valve; a duplex air pressure gauge, a plain triple valve, an auxiliary reservoir, a brake cylinder, with a piston in it, and the necessary piping stop-cocks and angle cocks.

Q. 4. How many kinds of triple valves are there in use?

A. Two; the plain and the quick-action triples.

Q. 5. What is the main reservoir used for, and where is it located?

A. Primarily for the storage of a large quantity of air, to be used in releasing the brakes and quickly recharging the auxiliaries; and secondarily, to catch the moisture, dirt, and oil which are pumped in along with the air. It may be located in any convenient place about the engine or tender, but it is usually placed under the boiler, just back of the cylinder saddles, or under the running board.

Q. 6. What is the usual standard train-pipe pressure?

A. With the plain quick-action brake 70 lbs., and with the high-speed quick-action brake 110 lbs.

Q. 7. What pressure is usually carried in the main reservoirs?

A. With the plain brake, 90 lbs.; with the high-speed brake, from 120 to 130 lbs.

Q. 8. Why is it important that all air-brake apparatus should be kept tight and free from leaks?

A. In order that the air-brake mechanism may operate properly and that there may be no waste of air, with its



attendant evils, or any unnecessary work required of the pump.

Q. 9. Where does the air come from that operates the sand-blower, bell-ringer, air-whistle signal, water-scoop, or other devices?

A. From the main reservoir.

Q. 10. How should an air-pump be started?

A. Very slowly, with all drain-cocks wide open. After the water has drained away, close all drain-cocks, and when a pressure of 35 or 40 lbs. has accumulated in the main reservoir, open the pump-throttle sufficiently to run the pump at a speed that will maintain the required pressure and perform the brake work satisfactorily. The steam end of the pump should be lubricated freely during the starting, just after the drain-cocks are closed.

## SECOND YEAR EXAMINATION.

### *General Questions.*

Q. 1. Has there been anything in the past year to interfere with your preparation for this examination?

A. The answer to this question will depend upon anything interfering or not.

Q. 2. Have there been any new signals introduced during the year or any changes on the old ones?

A. This question will be answered according to the knowledge of the candidate about signals.

Q. 3. Have you made any improvement in your method of firing, and have you obtained any better results economically and in smokeless firing during the year?

A. The answer to this question will also be based on the candidate's experience and progress.

THE LOCOMOTIVE BOILER.

Q. 4. Describe the general form of a locomotive boiler.

A. It is a cylindrical form of varying length and diameter, with a fire-box in the rear and a smoke-box in front. Flue-tubes extend from the front of the fire-box to the smoke-box and carry through the boiler the hot gases generated in the fire-box.

Q. 5. How does the wide fire-box boiler with fire-box projecting at each side beyond the wheels differ from the narrow fire-box set between the wheels, and what advantage has the wide fire-box over the narrow fire-box?

A. The purpose of the wide fire-box is to provide a larger grate area than what can be obtained with a fire-box set between the wheels. It is also easier to fire properly than a very long narrow fire-box.

Q. 6. What is a wagon top fire-box?

A. A boiler with that part of the shell above the fire-box raised above the level of the waist or cylindrical part of the boiler.

Q. 7. Describe a locomotive fire-box.

A. The ordinary fire-box is an oblong or nearly square box secured to the back part of the boiler. It is so constructed that water spaces are provided between it and the outside shell at the sides and the back. The fire-box is secured to the outside shell by stay bolts, and at the front end of the fire-box is a flue sheet with the flues secured therein. At the bottom part of the

in a frame attached to the mud ring, and beneath these fire-box is a bar called the mud ring, conforming to the shape of the fire-box, to which the outside and inside sheets of the fire-box are riveted. Beneath the grates an ash-pan is secured. The crown-sheet is sometimes supported by bars set on edge but more generally by stays of various kinds.

Q. 8. Why have two fire-doors been placed in some of the wide fire-boxes?

A. To make it easier to spread the coal over every part of the grates.

Q. 9. To what strains is the locomotive fire-box subjected?

A. First, to the strains due to high pressure of steam; second, to the strains that arise from varying temperature with the hot water on one side of the sheets and a hot flame or, perhaps cold air, on the other side. Then the changes of temperature act to lengthen or shorten the sheets, putting great strains upon the material. Varying temperature of feed-water also puts strain upon the fire-box.

Q. 10. How are the side and end sheets of the fire-box supported?

A. The sides and back sheet are supported by stay bolts; the front sheet by the tubes. All these sheets are supported by the mud ring.

Q. 11. What purpose is served by the small hole drilled in the outer end of stay-bolts?

A. To give indication by leakage when a stay-bolt breaks.

Q. 12. In what manner is a crown-sheet supported?

A. Sometimes by crown bars, but generally by stay-bolts.

Q. 13. What is a bad feature about crown bars?

A. They impede circulation of water and collect scale and mud.

Q. 14. What are the advantages of radial-stayed crown sheets?

A. The radial stays offer little obstruction to the free circulation of the water. They also put less weight on the fire-box than crown bars; and do away with the need of sling stays to bind the fire-box to the shell.

Q. 15. How are the inside and outside sheets secured at the bottom?

A. By the mud ring, or foundation ring, as it is sometimes called.

Q. 16. Describe the ash-pan.

A. It is a sheet-iron pan that conforms to the outline of the mud ring and is secured thereto. There is a door at each end called a damper for restraining or cutting off the supply of air when necessary and to provide means for removing cinders and ashes that the ash-pan collects.

Q. 17. Why are boilers provided with steam-domes?

A. The dome provides a location for the throttle-valve removed considerably above the water level in the boiler. This tends to prevent water from passing into the dry pipe along with the steam.

Q. 18. What must be the condition of a boiler in order to give the best results?

A. It must be kept as clean as possible and as free from scale and mud as circumstances will permit.

Q. 19. What is meant by circulation in a boiler?

A. The circulation is the moving of the water from one point to another inside the boiler. Circulation tends

downwards at the cooler parts and upwards close to the heating-surfaces. It is strongest about the fire-box and arises from the heated water moving upwards and to the stirring given to the water by the steam rushing away from the heating-surfaces. There is a theory that the water at the sides and end of the fire-box flow downwards at the outside sheet and upwards on the hotter inside sheet.

*Q.* 20. What would be the result if a leg of the fire-box became filled with mud?

*A.* The fire-box side sheet would become overheated.

*Q.* 21. What would be the result if the fire-box sheets became overheated?

*A.* The sheets would bulge between the stay-bolts and would be likely to crack. If they were overheated by becoming dry rupture might ensue.

*Q.* 22. Why are boiler checks placed so far away from the fire-box?

*A.* The checks are placed at the coolest part of the boiler so that the fire gases that have been cooled in passing forward may still be able to impart some heat to the incoming water.

*Q.* 23. What part of the locomotive boiler has the greatest pressure?

*A.* The steam pressure is uniform throughout, but there is a little pressure due to the weight of the water, and that is greatest on the lowest point which is the mud ring.

*Q.* 24. What should be the length of a locomotive smoke-box?

*A.* The ideas of designers vary greatly on this point. Extension smoke-boxes vary from 40 to 60 inches. The

most common length on the New York Central Lines is about 65 inches for passenger and 60 inches for freight engines.

Q. 25. What object is there in having the exhaust steam go through the stack?

A. For the purpose of creating draft.

Q. 26. How does this effect the fire?

A. The suction or draft created by the exhaust steam causes a partial vacuum in the smoke-box which draws air through the grates, thereby stimulating the fire.

Q. 27. What should be done to prevent black smoke from trailing when the throttle is closed?

A. The dampers should be closed, the fire door partly opened, and the blower started sufficiently to clear away the smoke.

Q. 28. What are the adjustable parts in the front end by which the fire is regulated?

A. With an extension front the diaphragm plate in front of the tubes is adjustable. With a diamond stack an adjustable lift pipe is generally set between the nozzles and the base of the stack. A lift pipe is sometimes also used with an extension front.

Q. 29. Explain what adjustment can be made and the effect of each adjustment on the fire.

A. When the diaphragm plate has the lower part too far away from the tube plate there is danger of spark-throwing and the fire gases will pass too freely through the upper rows of tubes. With such a defect the fire is burned more actively on the back part of the grates than in front. If the plate is set with the lower part too near

the tube plate draft will be obstructed and the fire will burn most actively in the front part of the grates.

There is no hard-and-fast rule for the adjustment of the lift or petticoat-pipe. It is usually set with the bottom of the flare level with the top of the nozzle. If the draft cuts the front of the fire too much the petticoat-pipe ought to be raised a little. If the back part of the fire is cut it ought to be lowered. Diaphragm and lift pipe ought to be set so that the fire gases will be drawn evenly through all the tubes.

Q. 30. What is out of place where the exhaust steam strikes the side of the stack?

A. Generally the lift pipe. That result will also come from the nozzle being out of plumb.

Q. 31. What effect has the stoppage of a number of flues?

A. It reduces the steam-making capacity of the boiler. Makes boiler steam poorly.

Q. 32. What is the effect of leaking steam-pipe joints inside the smoke-box?

A. It injuriously affects the steaming of the boiler.

Q. 33. What causes pull at the fire door?

A. Diaphragm plate or lift pipe being set too high.

#### FIRING.

Q. 34. Give briefly your opinion as to the best method of firing locomotives.

A. In the manner that will generate steam freely with the smallest quantity of coal. This is done generally by steady firing with the quantity to suit the way the engine is working.

Q. 35. If upon opening the fire door you discover what is commonly called "red" fire what might be the cause?

A. The free passage of air through the grates being obstructed.

Q. 36. Is it a waste of fuel to open the fire-box to prevent safety-valves from blowing? How can the necessity for this be prevented?

A. First, it is a waste of fuel. Closing the dampers and starting the injector are the easiest remedies. Second, escape of steam through the safety-valves blowing may generally be prevented by careful firing and forethought when approaching stopping-places. When blowing off steam cannot be prevented, some of the heat may be saved by blowing the steam into the tender.

#### OPERATION ON THE INJECTOR.

Q. 37. What is an injector?

A. An injector is an apparatus in which a jet of steam condensed by water imparts to the latter its velocity, with the result that the final energy of the combined steam and water is greater than that at which the water would issue from the boiler. This difference of energy in favor of the jet passing through the injector enables it to lift the boiler check and enter the boiler.

Q. 38. In a general way what are the two kinds of injectors?

A. In a general way, injectors are known as "Single Tube" injectors, when they have a single set of nozzles, and as "Double Tube" injectors when they have two sets of nozzles; one of the latter kind has the function of



lifting the feed-water and delivering it to the forcing set, which latter imparts to the water sufficient velocity to cause it to enter the boiler.

Q. 39. What is the difference between a lifting and a non-lifting injector?

A. A lifting injector is placed above the highest water-level of the tank from which the feed-water supply is taken, so that the injector has to lift the water up to its own level. A non-lifting injector is placed below the lowest level of the water of the tank from which the feed-water is taken, and it flows to the injector by gravity.

Q. 40. What are the essential parts of an injector?

A. The essential parts of injectors are, in the first place, the nozzles, which perform the function of delivering or forcing the water into the boiler, and, in the second place, the operating mechanism, such as the lifting-valve, steam-valve, water-valve, etc.

Q. 41. How should an injector be started?

A. In starting an injector, if it is a lifting one, the lifting-valve should be opened first, and when the water appears at the overflow, the forcing-valve of the injector should be opened gradually to its full extent. In starting a non-lifting injector the water should be admitted to the injector first, and when it appears at the overflow the steam-valve should be opened gradually to its full extent.

Q. 42. Give some of the common causes for failures of injectors to work.

A. The most common causes for failure of injectors are the following: Leak in the suction-pipe. Obstructed strainer or strainer of insufficient size. Liming up of the nozzles. Loose hose lining. Obstructions in the nozzles,  
/

such as pieces of coal, or other foreign matter washed in from the tank. Obstructions in the delivery-pipe, such as a sticking boiler check which will not open properly. Leaky steam-valve and boiler check, which will affect the starting of the injector by heating the suction-pipe and the feed-water.

Q. 43. What course should be pursued with the check-valve stuck open?

A. In case the check-valve is not provided with a stop-valve, it will be necessary to close the heater-cock and water-valve of the injector, to prevent water from the boiler from running out through the injector. In this case reliance for feeding the boiler must be had on the injector, the check of which must be in good condition. If the boiler check has a stop-valve, this can be closed down to shut off the boiler pressure from the check, in which case the check can be taken out for cleaning or for the removal of the causes which made the valve stick open.

Q. 44. How may it be determined whether the check-valve or steam-valve is leaking?

A. To determine whether the check-valve is leaking the frost-cock, with which all delivery-pipes and most check-valves are provided, should be opened. If water continues to issue from this frost-cock, the indication is that the check-valve is leaking. To determine whether the steam-valve is leaking, the cap of the heater-cock and the heater-cock check should be removed. If the steam-valve is leaking, steam will issue through the opening.

Q. 45. What may be done in this case?

A. In such cases the check-valve and the injector must be reported for repair, and the leaky valves ground in.

Sometimes the check valve may be sent to its seat by tapping the case with a piece of wood.

Q. 46. What may be done if a combining tube is obstructed?

A. In case the combining tube is obstructed, it must be removed, the nozzles thoroughly cleaned, and all obstructions removed.

Q. 41. How may it be determined if the trouble is on account of a leak in the suction-pipe?

A. When the suction-pipe leaks, the injector works with a hoarse, rumbling sound, caused by the air drawn in through the leaks. A leak in the suction-pipe may also be determined by closing the tank-valve, and opening the steam-valve of the injector slightly, with the heater-cock closed. If there is a leak anywhere in the suction line, the steam under such circumstances will issue through the leak.

Q. 48. What should be done in case of obstructed hose or strainer?

A. In case of an obstructed hose or strainer, the connection between hose and strainer should be broken, and with the heater-cock closed, steam should be blown back through the strainer. The water allowed to flow through the open hose will usually wash out the obstruction. In most cases it will be sufficient to remove the waste cap of the strainer, and allow water from the tank to flow through to wash out the obstruction.

Q. 49. What should be done in case the feed-water in the tank is too hot?

A. In case the feed-water in tank is too hot, it will be necessary to obtain fresh water as soon as possible to reduce the temperature.

Q. 50. Will an injector work if all of the steam is not condensed by water?

A. An injector will not work properly if all of the steam is not condensed.

Q. 51. If it is necessary to take down the tank-hose, how can the water be prevented from flowing out of a tank that has the siphon connection instead of the old style tank-valve?

A. In case a tank is provided with a siphon connection in place of the usual type of tank-valve, it is better to open the air-vent at the top of the pipe, in order to prevent the water from flowing out when the tank-hose is taken down. The sizes of the siphon pipes are usually large enough to admit air when the hose is disconnected, so that there is little danger of the water being siphoned out of the tank.

Q. 52. Explain how the water in the delivery-pipe can be protected from freezing.

A. If the injector is not in use for a long period in cold weather, the frost-cock in the delivery-pipe should be opened to prevent freezing.

Q. 53. Explain how you would prevent the waste-pipe freezing, either while the injector is working or shut off.

A. The waste-pipe contains water only during the short period when the injector is started, and even then it flows through the pipe at a rapid rate, so that the danger of freezing is very remote. When the injector is at rest, the waste-pipe is empty. A gradual freezing as a result of a badly leaking lifting- or steam-valve may be prevented by occasionally opening the lifting-valve slightly, and allowing steam to blow through the waste-pipe.

Q. 54. How can the suction-pipe and injector-hose be protected from freezing?

A. The suction-pipe and hose may be protected from freezing by using the injector as a heater.

Q. 55. Explain how the heater is used on a lever Monitor injector?

A. In connection with the lever-motion injector, it can be used as a heater by closing down the heater-cock and opening the lever very slightly, and fastening it in that position by means of the thumbscrew on the side of the lever.

Q. 56. How is the heater used with a screw Monitor injector?

A. With a screw Monitor injector it can be used as a heater by closing down the heater-cock and opening the steam-valve spindle about half a turn.

Q. 57. Is the indication of water-level by the gauge-glass a safe indication if the water-level in the glass is not moving up and down when the locomotive is in motion?

A. If the water-level in the gauge-glass of a locomotive is not moving up and down when the locomotive is in motion, the indication of the water-level is not a safe one.

Q. 58. Is any more water used when an engine foams than when water is solid?

A. When an engine foams, the consumption of water is decidedly greater than when the boiler does not foam.

Q. 59. How should an injector be stopped?

A. In stopping an injector, the steam-valve should be pressed firmly and gradually on its seat, avoiding (more particularly in the case of a lever mechanism) the closing

of the valve with a sudden shock, which injures the valve and its seat, and has a tendency to loosen these seats, where they are inserted in the body of the valve.

AIR-BRAKE QUESTIONS.

SECOND YEAR EXAMINATION.

Q. 1. Why is the present brake called the automatic brake?

A. Because it is automatic in its action; that is, its normal condition is when it is held off, due to the maintenance of train-line pressure, and anything which happens to reduce train-pipe pressure will cause the brake to apply of its own accord, or automatically.

Q. 2. Where is the compressed air stored?

A. In the main reservoir on the engine; in the train line which extends throughout the train, under the cars and connects the brake-valve with the triple valves, and in the auxiliary reservoir under each car.

Q. 3. What are the functions of the auxiliary reservoir, train-pipe, triple valve, and brake-cylinder?

A. The auxiliary reservoir holds a storage of compressed air for supplying the brake-cylinder with pressure with which the brake-piston is pushed out, engaging the system of levers which brings the brake-shoes up against the wheels and supply braking power. The train-pipe stores a quantity of compressed air, which holds the triple valve in release position normally, but when the train-pipe pressure is reduced, the triple valve will shift and apply the brake. The triple valve performs a three-fold func-

tion. When in release position, it permits a charge of pressure to pass from the train-pipe into the auxiliary reservoir. In application position, it permits pressure to pass from the auxiliary reservoir into the brake-cylinder. In release position, it permits pressure to discharge from the brake-cylinder to the atmosphere. Thus air passes through the triple valve three times. The brake-cylinder receives pressure from the auxiliary reservoir in service application, and from both train-pipe and auxiliary reservoir in emergency application, which pushes out the piston and applies the brake.

Q. 4. Where does the pump deliver the air?

A. To the main reservoir on the engine.

Q. 5. Where does the main-reservoir pressure begin and end?

A. It begins with the discharge-valves of the air-pump and ends at the rotary valve of the engineer's brake-valve.

Q. 6. What is excess pressure?

A. That amount of pressure contained in the main reservoir higher than that in the train line, available for releasing brakes.

Q. 8. How should a brake be cut out?

A. By turning the stop-cock in the branch or cross-over pipe.

Q. 9. How should the handle of cut-out cock stand when closed?

A. Parallel with the pipe.

Q. 10. How should handle of the angle-cock stand when closed?

A. At a right angle with the pipe.

Q. 11. What does line, or mark, at end of plug-cock indicate, regardless of position of handle?

A. This line, or mark, indicates the direction of the passageway through the plug-cock, and by it may be known whether the cock is open, regardless of the handle itself.

Q. 12. How should a brake be "bled" off?

A. The release-valve should be sharply opened for an instant, then quickly closed. This operation may be repeated until the triple valve begins to discharge the air, which can be heard at the retaining-valve or exhaust-port of the triple, then no further opening of this valve should be made.

Q. 13. When should the brake-valve be used in the emergency position?

A. Only in extreme emergency cases to prevent accident, such as loss of life or property, then the handle should be placed in the emergency position and left there until the train stops or the danger of accident is over.

Q. 14. What does the red hand on the air-gauge register?

A. Main-reservoir pressure.

Q. 15. What does the black hand register?

A. The pressure above the equalizing piston and in chamber *D*. This pressure may be properly classed with train-line pressure.



## THIRD YEAR EXAMINATION.

*General Questions.*

## ENGINEER'S FIRST DUTIES.

Q. 1. What are the duties of an engineman before attaching the locomotive to the train?

A. The duty of the engineman is to thoroughly inspect his engine for possible defects of machinery. He should know the condition of the fire-box, grate-bars, etc.; that gauge and water-glass cocks are open and working freely, and that the crown-sheet is covered with sufficient water to protect it from injury, and that the tender has been supplied with water. He should also know the condition of the engineer's brake-valve and air-pump, and take such other precautions as would prevent an engine failure.

Q. 2. What tools should there be on the locomotive?

A. The engine should be provided with such tools as are found necessary in everyday work. This includes also tools with which to make repairs in case of accident. Rake, coal-pick and shovel are classed as tools.

Some companies specify that tools ought to be carried on the engine. Where that is done the answer to this question should be regulated accordingly.

*General Questions.*

Q. 3. What examination should be made after any work or repairs have been done on valves, brasses, etc.?

A. A man should satisfy himself by personal inspection

that the work has been properly done, that all movable parts have been returned to place and properly secured by bolts, set-screws or otherwise.

Q. 4. How can it be known whether a boiler is carrying the proper steam-pressure?

A. By the safety-valves and steam-gauge, which should correspond with the prescribed pressure as established by the company.

Q. 5. What attention should be given to boiler attachments, such as gauge-cocks, water-glasses, etc.?

A. It should be known that they are open and working freely at all times.

Q. 6. Is smokeless firing practicable?

A. It is practicable with certain kinds of coal. With other kinds of coal the best a fireman can do is to fire frequently, keeping the fire as thin as practicable.

Q. 7. Trace the steam from the boiler through the cylinders to the atmosphere, and explain how it transmits power.

A. Steam enters from the main throttle located in the dome into the dry-pipe, thence to the steam-pipe and into the steam-chest. From the chest it passes through the admission-port into one end of the cylinder and forces the piston to the opposite end. When the piston has very nearly completed the stroke, the movement of the valve, which is in the opposite direction to the movement of the piston, establishes communication with the exhaust-passage and permits the steam to pass through the exhaust-passage into the stack and thence to the atmosphere.

Q. 8. How much power have the piston and cross-head on one side to turn the crank-pin, when the center of the

wrist-pin, the crank-pin, and the main-driving axle on the same side are in a straight line?

A. None whatever.

Q. 9. How then is the engine kept going?

A. Since a locomotive consists of two complete engines whose main-rods transmit their power to the same driving-shaft upon which the main-pins are at right angles to one another, it follows that the engine whose main-pin is on either the top or bottom quarter exerts sufficient power to cause the wheel to rotate, carrying the pin on the opposite side past the dead center to a point where the steam becomes effective to move the engine on that side.

Q. 10. What is meant by "working steam expansively?"

A. By working steam expansively is meant the process by which the steam is let into the cylinder and cut off before the piston has finished its full stroke, thereby allowing the expansive force of the steam to exert a certain amount of energy on the piston from the time that cut-off took place up to the point where release occurs.

Q. 11. How should the locomotive be started to avoid jerks, and what train signals should be looked for immediately after starting?

A. The engine should be started with the reverse-lever in full gear in the direction in which the locomotive is expected to move, and a gradual admission of steam.

Signals should be carefully looked for towards the rear end of the train to make sure that the entire train has been started.

Q. 12. After a locomotive has been started, how can it be run most economically?

A. By working steam expansively, that is, with the

reverse-lever cut back to a point where the engine will handle the train with a full throttle.

Q. 13. If you discovered that a fixed signal was missing or was imperfectly displayed, what should you do?

A. Stop. Ascertain the cause and report to the proper official from the first telegraph station as per standard or special rules covering this subject.

Q. 14. How rapidly should the water be supplied to the boiler?

A. Water should be delivered to the boiler steadily and in just sufficient quantity to replace the water which is being evaporated in doing work.

#### FOAMING AND PRIMING.

Q. 15. What is the difference between priming and foaming of a locomotive boiler?

A. Priming is carrying water along with the steam and is caused by water being carried too high, or from insufficient steam room in the boiler. Foaming consists of an aggregation of bubbles, or both, which carry the sediment to the surface. In both cases water is carried with the steam to the cylinder. To the ordinary observer priming and foaming are the same thing.

Q. 16. What should you do in case of foaming in the boiler?

A. The throttle should be either partly or entirely closed for a few moments to ascertain the water-level in the boiler. Where surface cocks are used, they should be used while the engine is at work, because they will

then carry away the scum which has been driven to the surface. When recourse is had to the blow-off cock, it can best be done when the engine has been shut off, as the sediment then settles to the bottom.

**Q. 17.** What danger is there when the water foams badly?

**A.** There is danger of exposing the crown-sheet to the intense heat through the water being too low, and liability of burning it. There is also danger of knocking out cylinder-heads.

#### ADJUSTING ROD BRASSES AND SETTING UP WEDGES.

**Q. 18.** What work about a locomotive should be done by the engineer?

**A.** He should set up the wedges and key up the rod brasses. Some railroad officials do not permit the engineers to adjust wedges or brasses.

**Q. 19.** How should the work of setting up the wedges be done?

**A.** The engine should be placed with the crank-pin of the right side on the upper forward eighth, which brings the crank-pin-of the left side on the back upper eighth. Block the wheels, and with the reverse-lever in the forward motion apply a small quantity of steam. As the action of the steam against the piston has a tendency to move it forward, the strain is thrown against the shoes, permitting a free movement of the wedges. The wedges should be set up with an ordinary wrench as far as possible and then pulled down again about one-eighth of an inch to prevent the box from sticking either from

overheating of the box or defective lubrication of the wedge.

Q. 20. How should the rod brasses be keyed?

A. The key should be driven down just enough to bring together brass to brass. Any greater force would spring the crown of the brass against the pin and cause is to heat.

Q. 21. How should an engine be placed for the purpose of keying rod brasses?

A. That depends entirely on which rods are to be keyed. If the main-rod is to be keyed, place the side of the engine upon which the work is to be done either on the upper forward eighth or the lower back eighth, as these positions present the greatest diameter of the pin to the rod brass and guarantee a free movement at all points without binding.

Q. 22. What is the necessity of keeping brasses keyed up properly?

A. To prevent unnecessary shocks and heating of rod brasses and pounding in driving-boxes, which in time cause undue strain on the entire motion with disastrous consequences.

Q. 23. How should the side rods on mogul and consolidation locomotive be keyed?

A. Place the engine on the dead center either forward or back. First key the middle connection, next the ends of rods and observe that the rod moves freely on the pin. Now place the engine on the opposite dead center, and notice if the rods move freely at this point also. This is particularly necessary with rod brasses having keys on both sides of pin and which are apt to be made

either too long or too short, throwing the rods out of tram and causing undue strain on rods and driving-boxes, and also danger of broken rods or pins.

Q. 24. What is meant by "engine out of tram?"

A. By an engine out of tram is meant one whose distance from center to center of axle or rod on one side does not coincide with the similar distance on the opposite side; or it may mean that the distance between two connected crank-pins is not the same as the distance between the two axles to which the crank-pins belong.

#### WHY SMOKE-BOX IS KEPT AIR-TIGHT.

Q. 25. Why is it important that there be no holes through smoke-box sheets or front and none in the smoke-box seams or joints?

A. There should be no possible chance for the admission of air to any part of the smoke-box, because it tends to destroy the vacuum necessary to create a perfect draft on the fire and also fans fires in the smoke-box that warp and destroy the sheets or front end.

#### VALVES AND PISTONS.

Q. 26. Describe a piston-valve?

A. A piston-valve is a cylindrical spool-shaped device having cast-iron packing rings sprung into place on the valve, and operating in a cylinder of equal diameter. The valve-cylinder is provided with suitable admission and discharge ports and permits the valve to perform the same functions as an ordinary slide-valve.

**Q. 27.** What is a balance slide-valve? How is it balanced and why? For what reason is the hole drilled through the top of the valve?

**A.** A balance slide-valve is one where a certain percentage of the steam-pressure exerted on the top of the ordinary slide-valve has been prevented.

The balancing feature is obtained by a steam table extending beyond the extreme travel of the valve, and either bolted to the steam-chest cover or cast in one piece with it. The Allen-Richardson valve has its valve grooved for the reception of four snugly-fitting strips, which are supported against the table by semi-elliptic springs, which make a steam-tight joint, and prevent any pressure reaching the enclosed part of the valve. The American balance-valve obtains the same results but uses circular, tapering rings supported by coiled springs.

The small hole in the top of the valve is for the express purpose of allowing any pressure or water which may have accumulated on the top of the valve from whatever cause to escape to the exhaust-port.

**Q. 28.** What is meant by inside and outside admission valves?

**A.** By inside admission valve is meant one where the steam enters the steam-port of the cylinder from the inside edge of the valve and is exhausted from the outer edge of the valve; by outside admission is meant one where steam enters the steam-port from the outer edge and is exhausted from the inner edge, similarly to our common slide-valve, which is an outside admission valve.

**Q. 29.** What is the relative motion of main piston and



valve for inside admission valve and for outside admission valve?

A. With inside admission the motion of the valve is in the opposite direction to the piston's motion at the beginning of the stroke. With outside admission the movement of the valve is in the same direction as the piston at the beginning of the stroke.

Q. 30. What is the difference in the valve motion for outside admission valves and inside admission valves?

A. Both may have either direct or indirect motion, according to the position of the eccentrics on the shaft and the type of rocker-arm used.

Q. 31. What is a direct-motion valve-gear? What is an indirect-motion valve-gear?

A. A direct-motion valve-gear is one that transmits the motion of the eccentric to the valve direct by means of a transmission bar or its equivalent connecting with the valve-stem.

An indirect-motion valve-gear is one where the power is transmitted from the eccentric to the lower rocker-arm, which gives motion to the upper arm that moves the valve-rod connecting with the valve-stem.

Q. 32. What is meant by lead?

A. Lead is the amount of opening a valve has when the piston is at the beginning of the stroke.

Q. 33. What is meant by steam-side lap?

A. By steam-side lap is meant the amount the valve overlaps the steam-ports, when the valve is on the middle of the seat.

Q. 34. What is meant by exhaust-side lap and by exhaust-side clearance?

A. Exhaust-side lap is the amount the inner edge of the valve overlaps the steam-ports when the valve is in the middle of the seat.

Exhaust-side clearance is the amount the inside edge of the valve comes short of covering the ports when the valve is in the middle of the seat.

Q. 35. With an indirect valve motion, what would be the position of the eccentric relative to the crank-pins? With direct-motion valve-gear? Why?

A. If the valves are the inside-admission indirect, necessitating a rocker-shaft, the eccentrics would lean toward the fire-box when the main-pin is on the forward dead center; while an outside admission indirect has the belly of the eccentrics leaning toward the main-pin.

With an inside-admission direct and a transmission bar, both eccentrics lean toward the pin; while with the outside admission direct the eccentrics have the same position as with the inside-admission indirect. With the inside admission indirect the eccentric-rods are crossed, when the crank-pin is on the forward dead center; the eccentric-rods with the outside admission direct are also crossed when the crank-pin is on the forward dead center.

These positions of the eccentrics are necessary with the corresponding valve motion to secure correct movement of the valves.

Q. 36. What effect would be produced upon the lap and lead by changing the length of the eccentric-rods?

A. If the valves are set so that they travel an even distance over the center of the valve-seat, changing the

length of eccentric-rods would make the valves travel unevenly, opening the steam-ports too much at one end and too little at the other. Changing the length of the eccentric-rods after the valves have been properly set would produce too much lead on one rod and not enough at the other.

Q. 37. Why are eccentric-rods made adjustable?

A. To allow for adjustment of the valve-travel, so that even steam admission may be made at both steam-ports.

#### CYLINDERS, PISTONS, AND PACKING.

Q. 38. Why it is necessary to keep the cylinders free from water?

A. To prevent rupture of cylinder and head which would necessarily occur should much water which is incompressible remain after the valve had closed all communication and the piston been forced to the end of its stroke.

Q. 39. Where is the piston-rod packing located?  
Cylinder packing?

A. The piston-rod packing is located in the back cylinder-head.

Cylinder packing is to be found in the grooved receptacles provided for that purpose in the circular surface of the piston.

Q. 40. How are the metallic packing-rings on valve-stems and piston-rods usually held in place? And what provision is made for the uneven movement of the rods?

A. Metallic packing-rings are held in place by stiffened spiral springs pressing against a ring and forcing the packing into a bell-shaped cone.

Suitable provision is made for the uneven movement of the rods in that the cone holding the metallic packing has a ground and steam-tight joint, which permits the cone to have a lateral motion against the face of the packing-gland, and thereby prevents the escape of any steam.

#### CAUSE OF TANK SWEATING.

Q. 41. What is the cause of tank sweating? And what will prevent it?

A. Sweating on the tank is caused by the cold water inside condensing the moisture in the air. It can be prevented by raising the temperature of the water in the tank to the temperature of the air.

#### FRICITION AND LUBRICATION.

Q. 42. What is friction?

A. Friction is the resistance between two bodies in contact, which resists the sliding of one upon the other.

Q. 43. Upon what does the amount of friction depend?

A. The amount of friction between two bodies in contact depends on pressure, temperature, speed, kind of material, and quantity and quality of lubricant.

Q. 44. What is the effect of the introduction of oil or other lubricants between frictional parts?

A. It reduces friction in proportion to the quantity and quality of lubricant used.

Q. 45. Explain the principle on which grease-cups operate. What is the objection in using water on a

hot pin where grease is used, or a hot pin with babbitted brasses?

A. The principle on which grease-cups operate is that of compression and expansion. As grease reduces friction less rapidly than oil, a certain amount of heat is generated, and as grease expands more rapidly than metal, it is forced through the aperture in the cup down upon the pin.

As one of the ingredients of "rod grease" is lye, and as lye will freely dissolve in water, the application of water to a pin will remove the "grease" and destroy lubrication.

The intermittent use of water on hot pins provided with babbitted brasses, where oil is used as a lubricant, has a tendency to clog the feeder with babbitt metal, thereby preventing the flow of oil to the pin. It also produces unequal contraction of the pin, often with disastrous results. There can be no bad effect from the continuous use of water, if used before the brass becomes overheated and before the babbitt starts to melt.

#### BLOW-OFF COCK.

Q. 46. Explain the construction and operation of the blow-off cock?

A. A blow-off cock may be either a globe-valve operated by a screw, a taper plug-valve operated by a lever, a sliding disk-valve operated by a lever, or a plunger-valve upon whose upper end either steam or air may be forced to unseat it.

The object of any of these valves when open is to

permit the escape of sediment and impurities from the boiler, and for that reason they are located at the bottom of the boiler.

#### BELL-RINGER.

Q. 47. Describe a bell-ringer; and how may it be adjusted?

A. The automatic bell-ringer is a device whose mechanism consists of a valve having either a sliding or rotary movement and provided with a suitable admission and exhaust-port, a piston operated in a cylinder, and a piston-rod connected to the bell-crank so as to impart a swinging movement. The motive power is air taken from the main reservoir.

Some types are provided with a threaded stem and a jam nut by which adjustment can be made, while others have a piston-rod operating like a telescope and requiring no adjustment.

#### USE OF THE BLOWER.

Q. 48. How should the blower be used when an engine is on the cinder-pit?

A. The blower should be used with just enough force while cleaning the fire to prevent the escape of gases from the fire door and possible injury to the fire-cleaner.

When the engine is at rest it is sometimes necessary to use the blower to prevent the emission of smoke. In this case the fire door should be kept on the latch. The blower has sometimes to be used for stimulating

the fire when the engine is not steaming freely. In such cases it can be employed to best advantage when descending grades or approaching stations with the steam shut off.

#### ENGINE DISABLED ON THE ROAD.

*Q.* 49. In case the locomotive in your care became disabled on the road what should you do?

*A.* First, protect the train front and rear by flags the prescribed distance. Make such temporary repairs as are necessary to get the train to the next siding, in order to prevent blocking the main line. When on the siding make all the repairs practicable with the tools at hand. If the breakdown is of such a nature as to prevent the possibility of making even temporary repairs, so as to clear the main lines, arrange to notify the nearest telegraph office of your location and ask for assistance.

*Q.* 50. Suppose a wash-out plug blew out, or a blow-off cock broke off or would not close, what should be done?

*A.* Draw the fire at once to prevent burning of fire-box sheets. In addition to this, in cold, freezing weather, the pet-cocks on all connections where there is any liability of water collecting should be opened to drain the pipes, and in the absence of cocks, the couplings should be slacked off. The tender-hose couplings should be disconnected and special care should be given to the air-pump drain-cocks to prevent the rupture of the steam-cylinder of pump.

If a heavy fire was on the grates it might be necessary to dampen it with earth or water before dumping it.

Q. 51. What should be done, should the grates be burned out or broken while on the road?

A. Block up the broken or burnt grates, with fish-plates, brick, or anything conveniently at hand, and disconnect the good grate immediately ahead and back of the burnt section in order to prevent disturbing the other grates when shaking down the fire.

#### TO PREVENT SPARK THROWING.

Q. 52. What precaution should be taken to prevent locomotives throwing fire?

A. In order to prevent engines from throwing fire, the netting in the smoke-stack or smoke-box should be carefully looked after, and the cinder slide and hand-hole plates must be in their proper places and securely fastened. Equally important is the knowledge that the ash-pan is clean, otherwise live coals, more dangerous than cinders, will roll out of the pan and start fires on bridges and along the company's property.

#### BURSTED OR LEAKY TUBES.

Q. 53. What should be done with a badly leaking, or bursted tube?

A. Where time and conditions permit, burst flues can be put in condition to bring in train. First, fill the boiler as full of water as it will hold, to compensate for loss. Then blow off steam through the whistle or remove release-valve from chest, open the throttle, and blow off



steam and deaden the fire so that the flue can be plugged. If the tube is burst, it must be plugged at both ends. If it is simply a case of leaky tube at tube-sheet, the above method is not necessary. Simply plug the tube. Bran or any starchy substance admitted through the heater-cock on injector after injector has been started will aid in stopping a bad leak.

Q. 54. Suppose that, immediately after closing the throttle, the water disappeared from the water-gauge glass, what should be done?

A. Disappearance of water from water-glass may be caused in various ways. The water may be bad and foamy, or the engine may have insufficient steam space, thus causing the water to prime, or the engineman may have taken too many chances on low water. As soon as the water disappears from the glass no time should be lost before banking or deadening the fire. Injectors should be kept at work until the water reappears in the glass before fire is rekindled.

#### THROTTLE-VALVE DISCONNECTED.

Q. 55. What should be done in case a throttle-stem becomes disconnected while the throttle-valve is closed; and if it becomes disconnected while the throttle-valve is open?

A. With a disconnected throttle closed—where the company requires the engineman to make repairs—steam must first be blown off and the dome-cap raised to reach the disconnected rod. Not enough power can be had from the oil-pipes to move the modern engine. If she

is equipped with a drifting-valve, she can be made to move herself without train.

If the throttle is disconnected and open, reduce pressure to a point where engine will not slip, and control the train by air-brake.

What is often mistaken for a disconnected throttle is merely a stuck throttle, due to excessive lost motion of parts, and occurs when giving full throttle. Tapping the throttle-rod often releases it from sticking.

#### ACCIDENTS TO VALVES OR VALVE MOTION.

Q. 56. In the event of a slide-valve yoke or stem becoming broken inside of the steam-chest, how can the breakage be located?

A. After satisfying myself that the eccentrics and visible parts of the valve motion were intact, consider the type of valve on the engine. With a broken valve-stem or yoke, the valve is always forced to the forward end of chest. With an outside admission piston-valve or a slide-valve, place the lever in the forward gear and watch the steam leaving the cylinder-cocks. Reverse the lever, and if the steam issues from both cocks on one side and from only the back one on the other, the latter has the disabled valve.

With the inside admission, steam would issue from the front and not from the back cylinder-cock. Where relief-valves are used, remove them first and watch movement of valve.

Q. 57. After locating a breakage of this kind, how

should one proceed to put the engine in safe running order?

A. If the engine had relief-valves on front end of chest, disconnect valve-rod; and, after forcing valve to central position to cover ports, clamp stem from one end and block with a plug driven into relief-valve of sufficient length to hold valve in place, leave up main-rod and proceed. If relief-valve were on back end, the chest cover would not have to be taken up, but back end of main rod would have to be disconnected and cross-head blocked ahead. The disconnected valve-rod would hold the valve against forward end of chest.

Q. 58. If a slide-valve is broken, what can be done to run the engine on one side?

A. If it is a balanced-valve and broken so that the steam-ports cannot be successfully covered, slip a heavy piece of sheet iron between valve and valve-seat, and block valve front and back. The balance-plate will then come down solid on valve and prevent leakage to cylinder.

With ordinary slide valve and similar conditions, remove valve entirely and block with hard wood, having the grain of the wood crosswise of the seat. With the sheet iron over the seat and the chest filled with blocking so that the cover will close down on it firmly and make a steam-tight joint, proceed on one side without disturbing anything except the valve-rod.

Q. 59. What should be done in case of link saddle-pin breaking?

A. Put the lever in a notch forward where one would be safe in starting a train. Then raise the link on the

disabled side to the same level as the good one, and block between top of link-block and link. Have another block ready of sufficient length to raise the link enough, should it be necessary to back up the engine.

Q. 60. With one link blocked up, what must be guarded against?

A. Reversing the engine, unless the disabled side has been changed by raising or lowering to correspond with the good side.

Q. 61. How can it be known if the eccentric has slipped?

A. By a lame exhaust, or with a bad slip, one of the exhausts disappearing entirely, and by watching the cross-head to note when the exhaust takes place.

Q. 62. Having determined which eccentric has slipped, how should it be reset?

A. Having located the eccentric, if it is a go-ahead, move the engine so that cross-head will come very near to the end of its travel ahead. Then move the eccentric around pointing in the opposite direction to the back-up, leaning either toward or from the pin—which would depend entirely on the style of valve and whether direct or indirect motion. As soon as steam appears at front cylinder-cock, tighten set-screws.

For back-up eccentric, lever and cross-head will have to be placed in the opposite direction. The best way is to mark eccentrics before starting, by placing the lever in forward notch and having cross-head at front end of travel. Then make a mark on cross-head and guide, doing the same with eccentrics and straps. If from any cause an eccentric slips and engine is placed so that mark

on cross-head corresponds with that on guide, the marks on three of the eccentrics will correspond with those on straps, while the fourth or slipped eccentric's mark will be some distance away from mark on its strap. By this method an eccentric can be set as true as any machinist can set it, and there is no guesswork.

Q. 63. What should be done in case of a broken eccentric-strap or rod?

A. Take down the other strap and rod, cover ports and leave main-rod intact.

Q. 64. How should the engine be disconnected if a lower rocker-arm becomes broken? If a link-block pin?

A. Unless the link interferes, all that is necessary is to remove broken part of the arm, cover ports by placing valve in central position and leaving main-rod up; otherwise the eccentric straps and rods would have to come down. With a broken link block-pin, there is more or less danger of interference between link and rocker-arm. Take down eccentric straps and rods only, and cover port.

#### ACCIDENTS TO RUNNING GEAR.

Q. 65. What should be considered a bad tender or engine-truck wheel?

A. One with sharp flange, or flat or shelled-out spots in tread of wheel,  $2\frac{1}{2}$  inches or more in length.

Q. 66. What should be done if an engine-truck wheel or axle breaks?

A. It should be entirely removed or blocked up so as to have the wheel clear of the rail, and the truck

frame should be securely fastened to the engine frame with chains.

Q. 67. What should be done if a tender-truck wheel or axle should break?

A. Pursue the same course as with the engine-truck wheel and fasten the truck frame with chains to the tender frame. Move slowly and cautiously to a point where repairs can be made.

Q. 68. How should an engine be blocked for broken engine-truck spring or equalizer? For broken tender-truck spring?

A. If pilot will not be too low, let truck frame ride on boxes; otherwise, block between top of boxes and truck frame.

Blocking for a broken tender spring will vary according to the type of truck used. Some have a coil spring over each axle-box and are easily taken care of; some have semi-elliptic springs with the spring band against the tender frame and the ends of spring resting on arch-bar over axle-boxes, while others have elliptic or coil springs supporting the truck-bolster and resting on the sand plank. With the first, block over the individual box; with the second, between truck-bolster and tender frame; and with the third, between truck-bolster and sand plank.

Q. 69. If it is not necessary to take down the main-rod or disabled side of the engine, how would one arrange to lubricate the cylinders?

A. By removing indicator-plugs, if the engine is equipped with them, oiling through them and replacing plugs.

If the engine has no plugs, shift valve just enough to show a little steam at cylinder-cocks and oil with the lubricator.

Q: 70. What should be done if a driving-spring, spring-hanger of equalizer should break?

A. Remove broken parts and block over box affected by break; as to blocking equalizers properly, one would have to be governed by the type of spring rigging used.

Q. 71. How can an engine be moved if the reverse-lever or reach-rod were caught at short-cut off by a broken spring or hanger?

A. By disconnecting the tumbling-shaft arm and blocking over link block-pin with blocking that would permit sufficient power to be used to start train.

#### BLOWS THROUGH VALVES OR PISTONS.

Q. 72. How can a blowing of steam past a valve, cylinder, packing or valve strip be distinguished and located?

A. When the valve has been placed to cover both steam-ports and no steam escapes from cylinder-cock but escapes through exhaust-port to stack, it indicates that valve strips are down or broken and permit steam to escape through small hole in valve to exhaust-port.

If valve covers ports and steam appears at both cylinder-cocks, it indicates a cut valve or seat.

If piston is at beginning of stroke and valve uncovered and steam escapes from cylinder-cocks at opposite end from which it is admitted, it indicates leaky packing-rings or cut cylinder.

A valve blow continues during the entire travel of valve, while a cylinder blow is strongest when piston is at beginning of stroke and gradually diminishes until cut-off takes place as piston nears end of stroke.

Q. 73. If a simple engine should blow badly and be unable to start the train when on the right-hand dead center, on which side would be the blow, generally?

A. On the left side, since that is the only power the engine has to move the other side off the dead center.

LEAKY THROTTLE, STEAM-PIPES OR DRY PIPE.

Q. 74. If the throttle were closed and steam came out of the cylinder-cocks what might be the cause?

A. Leaky throttle or dry pipe.

Q. 75. Is it possible to distinguish between a leaky throttle and a leaky dry pipe?

A. Yes; a leaky throttle will show dry steam only, while with a leaky dry pipe more or less water will pass out of the cylinder-cocks with the steam when the engine is standing, and when the engine is working she appears to be working water all the time.

Q. 76. What effect has leaky steam-pipes, and how should they be tested?

A. They interfere with the draft on the fire and prevent the engine from making steam.

Place the lever in the center, set the air-brake, open throttle, and watch the joints of steam pipes top and bottom. The proper test is the hydraulic test made in the shop.

Q. 77. How should the test for a leaky exhaust-pipe joint or a leaky nozzle joint be made?

A. By placing the level forward or back, moving the



engine slowly with brakes set, and watching the joints. Cinders never accumulate around such leaks and are always driven away from them.

#### ACCIDENTS TO VARIOUS PARTS.

Q. 78. How should hot bearings be treated?

A. They should be cooled down gradually, so as to prevent undue strain on the metal. The cause should be ascertained, whether defective lubrication or poor workmanship, in order to guard against a recurrence of the difficulty.

Q. 79. What should be done if a steam-chest cracks?

A. If the crack is not too serious, temporary relief can be obtained by driving wedges between chest-bolts and chest.

Q. 80. What should be done if a steam-chest breaks?

A. That depends on the type. With the chest commonly used, take up the chest cover, insert blocking in the steam passages to chest and bolt the cover down firmly upon them.

Q. 81. If a link lifter or arm were broken what should be done?

A. Block the same as for broken link saddle-pin.

Q. 82. If the reverse-lever or reach-rod should break, what should be done?

A. Follow the same method as for broken link saddle-pin.

Q. 83. What should be done if the piston, cross-head, connecting-rod, or crank-pin is bent or broken?

A. If the piston is broken or the piston-rod bent, remove both, disconnect valve-stem only, and cover ports.

With a broken cross-head or bent or broken main-rod, the main-rod would have to come down. Then, push piston ahead or back—this depends on the type of engine—and shift valve to force steam against piston in the direction in which it was desired to hold the piston, clamp valve, and block the cross-head as an additional precaution.

With a broken crank-pin the rod would not have to come down, but could rest on the yoke or guide. First ascertain in the case of a piston-valve whether it is an inside or outside admission before shifting, as the movement of the former is directly opposite to that of the latter.

Q. 84. What should be done if a safety-valve spring breaks?

A. Remove the spring and block between valve and cap, allowing the other valve to do the work.

Q. 85. How can an engine be brought in with a broken front end or stack?

A. By boarding up and by protecting it with the canvas curtain on the cab. Placing a barrel on smoke-arch in lieu of a stack will answer the purpose, but on a road with heavy traffic such expedients are not practicable.

Q. 86. What should be done when a frame is broken between the main-driver and cylinder?

A. The safest plan is to be towed in dead. The other alternative is to disconnect the disabled side and bring the engine in light, because an attempt to bring in part

of the train might damage the previously uninjured side.

*Q.* 87. What should be done when there is a loose or lost cylinder key?

*A.* If the key is loose and can be shimmed up, it is safe to go on. If key is lost and nothing available in its place, disconnect that side to prevent further damage.

*Q.* 88. What should be done if a frame is broken back of main driver?

*A.* Take down side rods on both sides back of main driver and proceed.

*Q.* 89. In case of broken side rods, what should be done?

*A.* Take down corresponding rod on opposite side also, and, if it is a consolidation, mogul, or 10-wheel engine, and the intermediate rod is broken, all side rods would have to come down.

*Q.* 90. What can be done if the intermediate siderods were broken on a consolidation engine, having the eccentric on the axle ahead of main wheel?

*A.* There is nothing to be done but to be towed in, unless only one side is broken, when it would be possible to bring the engine in under her own steam on one side, with the disabled side having its valve disconnected and ports covered, but this is not advisable, inasmuch as the engine might slip and break the other intermediate rod and do incalculable damage. All side rods ahead of the intermediate on both sides would have to come down.

*Q.* 91. Should one of the forward ties of a 10-wheel engine break, what must be done to bring the engine in?

*A.* Run the wheel upon a wedge so as to clear the rail

under all conditions; remove the oil-cellar and fit a block in its place; then place another block between bottom of box and pedestal binder. Also block under the equalizers nearest the disabled wheel to take the weight off the journal.

Q. 92. What is a good method of raising a wheel when jacks are not available?

A. To run them up on frogs or wedges.

Q. 93. How can it be known whether the wedges are set up too tight and the driving-box sticks, and in what manner can they be pulled down?

A. If the wedges are set up too tight, the boxes will heat, the engine will ride hard and have a rough, jerky, up-and-down motion.

Drawing down the wedge bolt snug and running the wheel upon blocks or wedges and off again will generally bring down a wedge as the box drops down. A little oil or kerosene between wedge and pedestal will often be a help.

#### REPORTING WORK TO BE DONE.

Q. 94. In reporting work on any wheel or truck on engine or tender, how should they be designated?

A. It should be designated as engine-truck, driver or tender-truck wheel, giving the exact location and side.

Some roads have adopted a method which prevents mistake by numbering the wheels, beginning at the forward engine-truck wheel on right side, going around the tender and ending with engine-truck wheel on left side, in consecutive numbers, as wheel No. 1, No. 2, No. 3, etc. On

an 8-wheel engine the right forward engine truck-wheel would be designated No. 1, while the left forward would be No. 16, according to this system.

Q. 95. What are some of the various causes for pounds?

A. Wedges not properly adjusted, loose pedestal braces, lost motion between guides and cross-heads, badly fitting driving brasses, improper keying of rod brasses, engine and rods out of tram, loose piston on rod or loose follower bolts.

#### POUNDING.

Q. 96. How can a pound in driving-box wedges or rod brasses be located?

A. By placing the right main-pin on the upper forward eighth, which brings the left main-pin to the upper back eighth. Then by blocking the drivers, giving the cylinders a little steam and reversing the engine under pressure, both sides can be tested at the same time.

Q. 97. When should cross-heads or guides be reported to be lined?

A. When there is sufficient lost motion between cross-head and guides to cause a jumping motion when the pin is leaving either dead center and the cross-head is beginning the return stroke.

Q. 98. When should driving-box wedges be reported to be lined?

A. When the wedge has been forced up as high as it can go and lost motion appears between wedge and box. It should then be reported lined down. Lining-up is sometimes reported by enginemen, but this is incorrect.

Q. 99. When should rod brasses be reported to be filed?

A. When there is sufficient lost motion to cause pounding.

Q. 100. When should rod brasses be reported to be lined?

A. When the key is down to a point where it cannot be forced down further to prevent brass working in strap.

Q. 101. When should lost motion between engine and tender be taken up?

A. When there is  $\frac{1}{4}$  inch or more lost motion between engine and tender, causing an undue strain on the draw-bar, by the forward and backward lurching of the engine while in motion, or the forward lurch in starting. It also causes severe strain on draft-rods.

#### HOW THE INJECTOR WORKS.

Q. 102. Describe the principle on which an injector works.

A. The principle on which an injector works is a combination of forces, velocity and an induced current of water passing through suitably proportioned tubes, designated as steam-nozzle, combining tube and delivery-nozzle. Under a given pressure the velocity of escaping steam is much greater than that of water, which would be ejected were a hole opened in the boiler below the water-line. The reduced orifice in the steam-nozzle naturally increases the velocity of the escaping steam as it enters the combining tube where it entrains the feed-water and

condenses. As the escaping steam is being condensed it has lost none of its velocity except that due to friction of the pipes through which it passes, consequently it has a vastly greater penetrating force after condensation than the resisting force in the boiler. Leaving the combining tube, the condensed steam and feed-water now pass through the delivery-nozzle into the branch pipe, where the ram-like force imparted to the water by the velocity of the escaping steam unseats the boiler check and permits the free flow of water to the boiler.

Q. 103. What is generally the cause of failure of the second injector, and what should be done to obviate this failure?

A. Infrequent use causes the various parts to corrode and check to lime over and stick. Frequent use and a trial before starting on trip will guard against such failures.

Q. 104. What are the advantages of the combination boiler check?

A. It reduces the number of boiler-check and injector failures.

Q. 105. If an injector stops working while on the road what should be done?

A. First ascertain the cause before applying the remedy. It may be due to a disconnected and closed tank-valve, clogged strainers, loose coupling in feed-pipe, which destroys the vacuum necessary to raise the water when starting a lifting injector, stuck check, etc.

Q. 106. How can a disconnected tank-valve be opened without stopping?

A. By closing the heater-valve and forcing the steam from injector back into tank to dislodge valve.

#### STEAM HEATING.

Q. 107. If the steam-heat gauge showed the required pressure, and cars were not being heated properly, how should one proceed to locate the trouble?

A. First make sure that the connections on the cars were all coupled and their respective valves opened to the rear end of train. If no steam appeared at rear car, examine each angle-cock or valve, and if these were open, look for the trouble at the regulator reducing-valve.

Q. 108. How does the steam-heat reducing-valve control the pressure?

A. By suitably adjusted springs and valves, which restrict the steam passages in proportion to the amount of tension of the springs exerted upon the valves.

#### ABUSE OF AN ENGINE.

Q. 109. What constitutes abuse of an engine?

A. Improper care, running with parts loose that could be readily made tight, working at a longer cut-off than necessary, pumping the water irregularly or in greater quantities than required. Running with fire door open, unnecessarily neglecting the adjustment of draft-appliances and failing to report needed repairs.

Q. 110. How are accidents and breakdowns best prevented?



A. By frequent and careful inspection before starting and during each trip.

Q. 111. What are the duties to be performed by an engineer when giving up his engine at the terminal?

A. To thoroughly inspect the engine and report all defects in an intelligent manner.

Q. 112. In what manner should an engine be inspected after arrival at terminal?

A. All running gear, frames, cylinders, saddles, bolts, wheels, fire-box, smoke-arch, and any other parts of the engine should be thoroughly examined and all defects correctly reported. No superficial examination is sufficient.

Q. 113. In reporting work on an engine, is it sufficient to do it in a general way, such as saying "Injector won't work," "Lubricator won't work," "Pump won't work," "Engine blows," etc.?

A. No; he should be explicit and assign a cause for every failure, so as to assist the shop force in remedying the defect.

#### FIRE-BOX QUESTIONS.

Q. 114. What causes the drumming sound sometimes heard in the fire-box of a soft-coal burning locomotive?

A. The combination of the combustion gases in a form that makes a series of minute explosions creating the drumming sound.

Q. 115. How can the disagreeable noise be stopped?

A. By closing a damper or putting the fire door on the latch.

Q. 116. What are the principal causes that prevent a locomotive boiler from steaming freely?

A. Badly adjusted draft appliances, leaky joints in steam-pipes, tubes choked up, too much piston clearance, valves and piston-packing blowing, and irregular boiler feeding, or inferior firing, and poor fuel.

#### PERIODS OF EXHAUST.

Q. 117. How often does an ordinary locomotive exhaust steam during a revolution of the driving-wheels, and at what periods do the exhausts take place?

A. Four times. Beginning with the right-hand piston moving from the forward center and the left crank set one-quarter behind the right-hand crank. When the right-hand cross-head has moved back to nearly the middle of the guides, the left-hand exhausts on forward stroke; when the right-hand cross-head reaches close to back of guides, the right-hand cylinder exhausts on backward stroke; when the cross-head returning reaches near the middle of the guides, the left-hand cylinder exhausts on backward stroke, and when the cross-head reaches close to the forward end of the guides, the right-hand cylinder exhausts on the forward stroke. That completes the cycle.

#### THIRD YEAR EXAMINATION.

##### AIR-BRAKE QUESTIONS.

Q. 1. Explain how an air-pump should be started to run on the road.

A. It should be started slowly to permit the condensation to be drained off. The lubricator should be started carefully, and the pump worked slowly until about 40 lbs. have been accumulated in the main reservoir to cushion the steam and air-piston of the pump. Then the throttle should be opened wider, giving a speed of about one hundred and thirty or one hundred and forty single strokes per minute. The amount of work being done really governs the speed of the pump.

Q. 2. How should the steam end of the pump be oiled?

A. By the sight-feed lubricator, with a good quality of valve oil, and at the rate of about one drop per minute. This amount will vary with the condition of the pump and the work being done.

Q. 3. How should air end of a pump be oiled, and what lubricant should be used?

A. High-grade valve oil, containing good lubricating qualities and no sediment should be used. A good swab on the piston-rod will help out a great deal. Oil should be used in the air-cylinder of the pump sparingly but continuously, and it should be introduced on the down stroke, when pump is running slowly, through the little cup provided for that purpose, and not through the air-suction valves. An automatic oil-cup, such as has recently come into practice, is preferable to hand oiling.

Q. 4. When first admitting steam to the  $9\frac{1}{2}$ -inch pump, in what direction does the main valve move?

A. If the main piston is at the bottom of the cylinder, as it usually is after steam has been shut off and gravity controls it, the main valve will move to the position to the right.

Q. 5. With the main valve to the right, which end of the cylinder will receive the steam?

A. The bottom or lower end.

Q. 6. When the main piston completes its up stroke, explain how its motion is reversed so as to make the downward stroke.

A. When the main piston reaches and is nearly at the top of its stroke, the reversing-plate catches the shoulder on the reversing-valve rod, moving the reversing-rod and valve to their upper positions, where steam is admitted behind the large head of the main valve, forcing this main valve over to the left, carrying with it the slide-valve which admits steam to the top end of the cylinder and exhausts it from the bottom end, thereby reversing the stroke of the pump.

Q. 7. Explain the operation of the air end of the  $9\frac{1}{2}$ -inch air-pump on an up stroke and on a down stroke.

A. The air-piston is directly connected with the steam-piston, and any movement of the steam-piston will consequently be transmitted directly to the air-piston. When the steam-piston moves up, the air-piston will, of course, go with it, thus leaving an empty space or a vacuum in the lower end of the air-cylinder, underneath the air-piston. Atmospheric air rushes through the air-inlet, raising the lower receiving-valve, and filling the bottom end of the cylinder with atmospheric pressure. At the same time the air above the air-piston will be compressed. The pressure thus formed holds the upper receiving-valve to its seat, and when a little greater than the air in the main reservoir, the upper discharge-valve will lift and allow the compressed

air to flow into the main reservoir. When the piston reaches the top of the stroke its motion is reversed, and on the down stroke the vacuum in the upper end of the air-cylinder is supplied by atmospheric pressure passing through the upper receiving-valve. The main reservoir pressure is held by the upper discharge-valve, and the air being compressed in the bottom of the cylinder holds the bottom receiving-valve to its seat, and when compressed sufficiently, forces the lower discharge-valve open and passes to the main reservoir.

*Q.* 8. Give some of the causes of the pump running hot?

*A.* First, air-cylinder packing-rings leaking. Second, discharge-valves stuck closed or the discharge-passages so obstructed that the pump will be pumping against high air-pressure continually. Third, poor lubrication. Fourth, high speed. Fifth, discharge or receiving air valves leaking. Sixth, air piston-rod packing leaking.

*Q.* 9. If the pump runs hot while on the road, how would you proceed to cool it?

*A.* First, reduce the speed of the pump, and look for leaks in the train-line. Second, make sure that the packing around the piston-rod is not too tight and in bad condition. Third, see that the main reservoir is properly drained. If the pump still runs hot it should be reported at the end of the trip.

*Q.* 10. If the pump stops, can you tell if the trouble is in the pump or in the governor?

*A.* Yes. It may be tested by opening the drain-cock in the steam-passage at the pump, and noting whether there is a free flow of steam; if so, there is a

free passage through the governor and the trouble is not there.

Q. 11. State the common causes for the pump stopping.

A. There are several reasons. First, it may be stopped by the governor being out of order; second, the valves may be dry and need lubrication; third, nuts may be loose or broken on the piston-rod or one of the pistons pulled off. Fourth, the reversing-valve rod may be broken or bent, or the reversing-plate may be loose, or the shoulder on the reversing-valve rod or the reversing-plate may be so badly worn as not to catch and perform their proper functions. Fifth, nuts holding the main-valve piston may be loose or broken off. Sixth, excessive blow past the packing-rings of the main valve.

Q. 12. Should a pump make a much quicker down stroke than up, what effect does it indicate?

A. An upper discharge air valve leaking, a lower receiving air valve stuck to its seat, or broken.

Q. 13. Should it make a much quicker up stroke, what defect does it indicate?

A. The lower discharge-valve leaking badly, or the upper receiving-valve is probably broken, or stuck to its seat.

Q. 14. Should an engineer observe the workings of a pump on the road, and report repairs needed, and do you consider yourself competent?

A. Yes.

## GOVERNOR.

Q. 15. What is the function of the air-pump governor?

A. To properly regulate the pressure in the main reservoir.

Q. 16. Explain how the governor operates.

A. The governor is an automatic arrangement for admitting and closing off steam to the air-pump, and is actuated by air-pressure. The steam-valve, which shuts off and opens up the steam passageway to the pump, is controlled by an air-piston and spring. When air-pressure is admitted above the piston, it forces the piston down, closing off the steam to the pump. When the air-pressure is exhausted from above the piston, the spring forces the piston up and allows steam pressure to pass to the pump. The admission and exhaust of the air to this piston is controlled by a diaphragm and spring. The air from the main reservoir enters the body of the governor underneath the diaphragm, which is held by a spring of given tension, depending on the pressure desired in the main reservoir. While the main reservoir pressure is less than the pressure the governor is set for, this diaphragm is held down by the spring, and the air can pass no farther than a small pin-valve attached to it, but when the main reservoir pressure overcomes the tension of the spring, it raises the diaphragm, unseats the pin-valve and allows the air to flow to the top of the air-piston, shutting off the pump. During the time the air is acting on this piston some of it escapes through a large leakage port, which is always open.

When the main reservoir pressure drops below the pressure the spring is adjusted to, the spring forces the diaphragm down, seating the pin-valve and allowing the air on top of the piston to escape to the atmosphere, through the small vent-port.

Q. 17. Why is it necessary that the relief-port in the improved governor be kept open?

A. If this port is not kept open, the air-pressure, which holds the piston down, cannot escape when the diaphragm valve closes, and consequently the governor will not operate the pump properly.

Q. 18. Where would you look for the cause, if the governor allowed a very high main-reservoir pressure to accumulate, especially in winter weather?

A. The main-reservoir pressure may not reach the governor, due to the stoppage in the pipe or in the union at the governor. This may also be due to the space on top of the diaphragm being filled with dirt. If the air is getting to the diaphragm-valve, and is so indicated by the blow at the leakage port, the trouble must then be due to the drip-pipe being stopped up or frozen, thereby preventing the air and steam, which leak in under the air-piston, from escaping.

Q. 19. If the pin-valve in the governor leaks, what effect will it have on the pump?

A. It will allow a certain amount of air-pressure to flow in on top of the air-piston. If the leak is greater than the escape from the little leakage port, the under pressure will accumulate and cause the governor to slow down or completely stop the pump.

Q. 20. How can you tell if the pin-valve leaks?



A. It will blow continually at the leakage port while the pump is running.

#### MAIN RESERVOIR.

Q. 21. What harm is there in allowing water to accumulate in the main reservoir?

A. It reduces main-reservoir capacity or space which should be employed in storing air-pressure for releasing and recharging the brakes. The moisture also is carried in the air, goes back into the train-pipe and gets into the triples, where it freezes in cold weather.

Q. 22. How often should the main reservoir be drained?

A. After each trip.

Q. 23. Where does the main-reservoir pressure begin and end?

A. It begins at the top side of the discharge-valves in the pump and ends on the top side of the rotary-valve of the engineer's brake-valve.

Q. 24. What is the main reservoir used for?

A. It is a storehouse, or storage-tank, for air-pressure, to charge and recharge the air-brakes.

Q. 25. What pressure is usually carried in the main reservoir?

A. Ninety pounds with the 70-pound brake, and about 130 pounds with the high-speed or 110-pound brake.

#### ENGINEER'S VALVE.

Q. 26. What kinds of engineer's brake and equalizing-discharge valves are used?

A. Three forms; the D-8 with the excess-pressure valve, the D-5 with the poppet-valve form of feed-valve, and the E-6, F-6 or G-6 with the slide-valve feed-valve attachment. These three forms are all of the equalizing discharge type, and have respectively excess pressure valve, the poppet-valve feed-valve, and the slide-valve feed-valve. The initial and figure designations given the forms of valves are those used in the different catalogues of the manufacturer.

Q. 27. How is the amount of excess pressure regulated when the G-6 brake-valve is used?

A. The slide-valve feed-valve attachment is adjusted by the regulating spring to control the train-line pressure when the brake-valve handle is in running position. The air-pump governor is adjusted to control the amount of pressure to be carried in the main reservoir. The difference between these two pressures is what is commonly known as "excess pressure," and is used for releasing and recharging the brakes.

Q. 28. How is the excess pressure regulated with the D-8 brake-valve?

A. With the excess-pressure valve spring. This valve will give the amount of excess pressure desired by placing behind the valve a spring of sufficient tension or resistance to cause the difference between the main reservoir pressure and the train-pipe pressure. For instance, if 20 pounds excess pressure is desired, the spring is so prepared that when the brake-valve handle is in running position the main-reservoir pressure passing to the train-pipe will meet a resistance of 20 pounds, thus giving 20 pounds more in the main reservoir than in the train-line.

Q. 29. How should the feed-valve of a G-6 brake-valve be cleaned?

A. The stop-cock in the train-pipe under the brake-valve should be closed, and all train-line pressure drawn off the brake-valve with the handle in service position, thus eliminating all chance of the parts being roughly moved or injured when the valve attachment is taken apart. Then remove the large cap nut, and take out the piston spring and slide-valve. Clean these parts carefully, taking care that no lint or dirt remains on the parts. Oil the slide-valve and its seat very sparingly with a good quality of oil, then replace the parts carefully. Next remove the diaphragm-valve, clean it carefully, taking especial care not to bruise or scratch its ground surface. The same care should be exercised in cleaning the diaphragm-valve seat, observing that none of the small ports are stopped or clogged with dirt or foreign matter. No oil is necessary on the diaphragm valve and its seat. As a rule, it is unnecessary to remove the regulating spring and diaphragm, but when it is necessary it should be done by the repair-man, and not when the engine is in service on the road if it can be avoided. In fact, all work possible should be done on the brake-valve by the air-brake machinist, either in the round-house or machine-shop.

Q. 30. Name the different positions of the brake-valve.

A. Full release, running, lap, service application, and emergency application.

Q. 31. In what position of the brake-valve is there direct communication between the main reservoir and train-pipe?

A. The first or full release position.

Q. 32. Is there no other position of the brake-valve in which the air may pass from the main reservoir to the train-line?

A. Yes; running position. However, in running position the air passes indirectly, or through the passages and ports of the feed-valve attachment, in order to get from the main reservoir to the train-line.

Q. 33. When making a service application, do you draw air direct from the train-pipe?

A. No. In service application the engineer draws air directly from the small equalizing reservoir and from the chamber on top of the equalizing-piston. This reduction causes a difference in pressures acting on the piston, and the train-line pressure under the equalizing-piston being greater causes the piston to rise and discharge train-line pressure at the angle fitting of the brake-valve until such time as the latter pressure becomes lower than that remaining on top of the piston, when the piston will descend, closing off the discharge of train-line pressure.

Q. 34. With the G-6 brake-valve in running position, if the black hand of the gauge goes up and equalizes with the red hand, what is the defect?

A. As the black hand indicates train-line pressure, and the red hand main-reservoir pressure, the train-line pressure is evidently being increased, due to the leakage of main-reservoir pressure coming into it. This leakage of main-reservoir pressure into the train-line pressure may be due to either a leaky rotary-valve or leaky body gasket. Also, there may be a leakage in the feed-valve attachment

past the supply-valve, or in the attachment gasket, or the regulating spring may be improperly adjusted.

Q. 35. How can it be ascertained which one of these defects is causing the trouble?

A. Discharge all air from the brake-valve. Place the brake valve handle on lap and start the pump. If there is a leakage of main-reservoir pressure into the train-line, which will be indicated by the rising of the black hand, the trouble is either in the rotary-valve and its seat, or in a defective body gasket. However, if the black hand does not rise while handle is on lap position, but if both hands go up together in running position above the figure the feed-valve adjusting-spring is set for, the trouble is probably either in a faulty supply-valve in the feed-valve attachment, or in the small gasket between the feed-valve attachment and the brake-valve body.

Q. 36. What is the effect of leakage from the equalizing-reservoir, or the connections to the small chamber above the equalizing-piston?

A. When a service application is made, the leakage from the equalizing-reservoir in the chamber above the piston will cause more air to escape than is desired by the engineer, the equalizing-piston will remain raised off its seat longer than intended, and more pressure will be drawn from the train-line than desired, thus making a heavier application than is wanted. In other words, a continuous, or at least prolonged, application will be made, and the engineer will be unable to reliably regulate the flow of pressure from the train-pipe in service application. In release and in running positions, this leakage will merely mean a waste of air-pressure. On lap, train-

line pressure will continue to escape at the angle fitting, either slowly or rapidly, according to the size of the leak.

Q. 37. Should the equalizing-piston fail to seat, how can it be known if it is due to dirt on the seat of the valve or leak of the equalizing-reservoir pressure?

A. This question was partly answered in the preceding. If there is dirt between the valve and its seat, there will be a constant flow of train-line pressure through the angle fitting at all times, but if the piston fails to seat, due to leakage from the equalizing-reservoir in the chamber above the piston, there will be no leakage of pressure at the angle fitting with the brake-valve handle in full release, or running position.

#### GENERAL.

Q. 38. If there is a continuous blow at the train-pipe exhaust-port, or angle fitting, what should be done to stop it?

A. If the blow is due to dirt between the valve and its seat, make several service applications and releases. If this does not stop the blow, the valve may be taken apart and cleaned, provided it is known that the trouble is caused by dirt between the valve and its seat. If the piston will not seat on account of leakage from the equalizing-reservoir in the chamber above the equalizing-piston, or the connections, each connection should be gone over carefully with soap suds to detect and locate the leak, and it should then be taken up. A torch blaze is not sufficient. If it is impossible to stop the leaks, on account of breakage of the parts, etc., a blind gasket may

be placed in the connection between the chamber *D* and equalizing-reservoir, plugging this opening, and a plug should be placed in the angle fitting of the train-pipe discharge, and braking be done very cautiously and carefully with the valve handle in emergency position. This latter, however, is an expedient that is very seldom necessary.

*Q.* 39. What is the effect of leaving the handle of the brake-valve in full release position too long, before returning it to the running position, after releasing brakes?

*A.* The train-line and auxiliary reservoirs will be charged higher than the feed-valve is adjusted for, thus permitting the equalization of pressures between the auxiliary reservoirs, train-line, and main reservoir. Should the handle be then drawn to running position, main-reservoir pressure will be unable to pass through the feed-valve attachment to the train-line until such time as the latter pressure becomes reduced below the point at which the feed-valve is adjusted. Should there be leakage in the train-line, brakes will apply and drag until the brake-valve is thrown to full release position, thus releasing the brakes. The brake-valve handle should not be left in full release position after releasing brakes.

*Q.* 40. If, from any reason, the brakes should drag, how can they be released from the engine?

*A.* If it is found that the train-line is overcharged before leaving a terminal, a fairly heavy application of the brake may be made in service position, and the brake-valve handle placed in running position. Several repetitions of this process may be necessary. However, if the overcharge occurs while the train is running, and brakes will not release in running position, the valve-handle may

be placed in full release position and left there until the next stop is made, and then care should be taken to not overcharge again in full release position, but to return to running position in due season, thus preventing this trouble. Sometimes a series of light applications and releases may while made be running to reduce an overcharged train-pipe; however, this is not practical on fast modern trains.

Q. 41. If the brakes apply suddenly, what should the engineer do?

A. Place the brake-valve in lap position and ascertain the cause. It will probably be due to a burst or parted hose, to the opening of a conductor's valve, or the rear angle-cock. However, regardless of the cause, the brake valve handle should be placed on lap, to save the main-reservoir pressure for releasing the brakes after the train-pipe opening has been closed.

Q. 42. If the pipe connecting the chamber above the equalizing-piston with the equalizing-reservoir should be broken off, what should be done?

A. Plug up the connection to chamber *D*, also the angle fitting on the underside of the brake-valve, and brake cautiously and carefully in the emergency application position.

Q. 43. What should be done if the pipe leading to the black hand or the air-gauge should break? If the pipe to the red hand should break?

A. If the black-hand pipe should break, plug the connection at the brake-valve, using careful judgment in gauging by sound the amount of pressure drawn from the equalizing-chamber in service application. If the red-



hand pipe should break, plug the connection at the brake-valve, taking care that the pump governor is operating and observing that sufficient main-reservoir pressure is being accumulated with which to release brakes after each application.

Q. 44. How is the train-pipe pressure regulated to 70 pounds, while the handle of the G-6 brake is in running position?

A. By the adjusting-nut and spring in the feed-valve attachment.

Q. 45. What is the reason for having the equalizing-reservoir on the brake-valve?

A. The equalizing-reservoir is used to give an enlarged capacity for the required volume of air-pressure on top of the equalizing-piston, to permit the equalizing-piston to draw pressure gradually from the train-pipe in service application. If this enlarged capacity were placed in the brake-valve, the valves would be entirely too large and bulky for location in the cab; however, this capacity is obtained by employing a reservoir of suitable capacity, and locating it in a remote and convenient place, and piping it to the brake-valve. If the reservoir was not used, and the chamber *D* capacity was restricted to its present size alone, it would be impossible to reduce pressure sufficiently slow to permit the piston to rise gradually as it now does; but instead the pressure would be exhausted quickly, the piston would rise suddenly and make a heavier application of the brake than was desired.

Q. 46. What effect would a leak from the equalizing-reservoir have?

A. It would be troublesome to the engineer, inasmuch as he would not be able to control the discharge of train-line pressure, as the leakage of pressure above the piston would cause the piston to discharge more train-line pressure than he intended and desired; hence, he would be unable to properly control brake applications on his train.

Q. 47. How can a leak past the packing-ring in the equalizing-piston be located?

A. Ascertain that the rotary-valve and body gasket are tight, place the brake-valve handle on lap position and open the angle-cock at the end of the tender, thus discharging train-line pressure below the equalizing-piston. If the black hand now falls, indicating a reduction of pressure in chamber *D* above the piston, that pressure is evidently passing by the piston into the train-pipe and out at the angle-cock. Another way is to observe whether the black hand rises when the brake-valve has been returned to lap after making a service application. With a long train, a leaky packing-ring would permit train-line pressure to leak past into chamber *D*, which would be indicated by a rise of the black hand on the gauge, during a service application.

Q. 48. What danger would there be from a leakage of main-reservoir pressure into the train-pipe, when the brakes were set and brake-valve was on lap position?

A. Such a leakage would increase the train-line pressure and cause the triple valves to go to release position, thus releasing the brakes.

Q. 49. What danger is there in a leak from the main reservoir to the train-pipe when the brakes are released and handle in running position?

A. The train would be overcharged, and no excess pressure could be carried, if the leakage were of such consequence and there were a considerable lapse of time between brake applications. This unduly increased train-line pressure would have a tendency to produce wheel sliding.

Q. 50. What repairs may be made on the road to overcome such leakage?

A. It does not pay to make road repairs generally, as frequently more harm is done thereby than good. The four bolts holding together the top and bottom portion of the valve may be carefully tightened, taking care not to break the bolts, and thereby creating a worse condition than existed before. It would be better to exercise unusual care and caution in handling the trouble while on the road, and report it upon arrival at the terminal.

#### TRIPLE VALVE.

Q. 51. How many kinds of triple valves are there in general use?

A. Two, the plain type and the quick-action type.

Q. 52. What is the function of the triple-valve piston, the slide-valve, and the graduating-valve?

A. The function of the triple-valve piston is, by variation of pressures on its two sides, to move the slide-valve on its seat to the application, graduating, and release positions, and to open and close the feed-groove in the piston bush. The function of the slide-valve is, by movement due to triple valve-piston, to make con-

nection between the auxiliary reservoir and brake cylinder, applying the brake, and to make connections between the brake-cylinder and the atmosphere, releasing the brake. The function of the graduating-valve is, from movement given by the triple piston, to admit pressure gradually from the auxiliary reservoir to the brake-cylinder, in response to reductions made in the train-pipe pressure.

Q. 53. Explain how the quick-action triple operates when making an emergency application of the brakes.

A. A sudden reduction of pressure in the train-pipe will cause the triple piston and its parts to be moved to quick action application position, which first throws into operation the emergency feature of the triple, admitting train-line pressure to the brake-cylinder, after which auxiliary reservoir pressure is permitted to pass to the brake-cylinder, where a higher pressure is obtained than in a full service application of the brake.

Q. 54. Name the parts of the quick-action triple valve that are not in the plain triple valve.

A. The emergency piston, the rubber-seated emergency valve, and the non-return check-valve and its spring.

Q. 55. Where does the air come from which sets the brakes in emergency with the plain triple valve?

A. From the auxiliary reservoir only.

Q. 56. Where does the air come from which sets the brakes when an emergency application is made with the quick-action triple?

A. The first portion of air going to the brake-cylinder is contributed by the train-pipe, after which the

auxiliary reservoir sends in its portion of air to the brake-cylinder.

Q. 57. What causes a blow at the triple-valve exhaust, and how may it be located?

A. This blow may be from three sources, the train-pipe, the auxiliary reservoir, or the brake-cylinder. If the blow is from train-line pressure, it may be detected by closing the stop-cock in the cross-over pipe, and the brake will promptly apply. If the blow is caused by auxiliary reservoir pressure, there will be a steady leak of pressure at the exhaust-port when the brake is released and the brake will not apply when the cut-out cock is closed in the cross-over pipe. If brake-cylinder pressure causes the blow, it will only happen when the brake is applied and will cease when the brake is released and the brake-cylinder empty of pressure.

Q. 58. About how much time is required to charge the auxiliary reservoir to 70 pounds in the train-pipe?

A. It should be no less than 45 seconds and no more than 70 seconds.

#### TRAIN AIR-SIGNAL.

Q. 59. Explain in a general way the operation of the whistle signal reducing-valve.

A. The valve consists of an adjusting or regulating spring which limits the amount of pressure which will pass through the valve, a piston and a supply-valve. If the spring is adjusted for 40 pounds, the standard pressure, the piston will descend and permit the supply-valve to close when 40 pounds has been reached, thus

shutting off further supply to the signal line. If the signal line reduces below 40 pounds, or what the valve is adjusted for, the adjusting spring and piston will permit the supply-valve to open and admit main-reservoir pressure, until the predetermined amount has been accumulated, when the supply-valve will then be closed.

*Q. 60.* Explain how the signals are transmitted from the car to the engine.

*A.* On the engine is a valve containing a rubber diaphragm, on the under side of which is suspended a stem which, when raised, will permit pressure to pass from the signal-valve outward through the air-whistle. When the pressure on the top side of this diaphragm is equal or greater than that on the under side, the stem will remain seated, closing the port to the whistle; however, if a reduction be made in the chamber above the diaphragm, or in the signal-line connected to this chamber above the diaphragm, the greater pressure on the under side will cause the diaphragm and stem to rise, permitting pressure to pass to the whistle producing the blast.

*Q. 61.* If the signal-whistle blows when brakes are released, where would you look for the trouble?

*A.* In the pressure-reducing valve. Dirt or other foreign substance has settled between the supply-valve and its seat, thus permitting main-reservoir pressure to accumulate in the signal-pipe. When brakes are released, main-reservoir pressure falling below the signal-line pressure will permit the signal-line pressure to pass backward into the main reservoir, making a reduction in the signal-pipe and on the top of the diaphragm

on the signal-valve, thus producing the blast the same as if a reduction were made at the car-discharge valve.

Q. 62. If the proper discharge of air is made at the car-discharge valve, and the whistle on the engine only responds with a weak blast, where would you look for the trouble?

A. The car-discharge valve may be partially choked, or the diaphragm stem in the signal-valve may be loose, responding poorly to a signal-line reduction. Also, the adjustment of the whistle bowl on the stem should be examined. Sometimes wind blowing across the whistle bowl when running may weaken the blast.

#### HIGH-SPEED BRAKE.

Q. 63. How much pressure is carried in the train-pipe when using the high-speed brake?

A. One hundred and ten pounds is generally adopted as the standard train-line pressure in high-speed brake service.

Q. 64. What changes are necessary in the usual quick-action car equipment to convert it into a "high-speed brake"?

A. An additional attachment to the brake-cylinder by pipe connections of the high-speed automatic reducing-valve.

Q. 65. What parts are necessary to change the engine and tender equipment to the "high-speed brake"?

A. A high-speed automatic-reducing valve for the tender brake-cylinder, another for the driver-brake, and

truck-brake cylinders, one reversing-cock, and the 90-pound and 110-pound feed-valve attachments, a Siamese fitting and second pump governor top.

Q. 66. At what pressure will the auxiliary reservoir and brake-cylinders equalize with an emergency application using the high-speed brake?

A. With a 7-inch piston travel the equalized pressures will be about 86 pounds.

Q. 67. Explain in a general way the operation of the high-speed reducing-valve.

A. The valve consists of a piston and stem whose downward movement is regulated by the adjusting spring. A small slide-valve with a triangular escape port is attached to the upper side of the piston. If the adjusting spring is set at 60 pounds, and an emergency application of the brake be made, the piston will descend when 60 pounds has been accumulated in the brake-cylinder, and the apex or smallest part of the triangular port will permit brake-cylinder pressure to pass through it and escape to the atmosphere; as the brake-cylinder pressure reduces, the piston will gradually move up a larger part of the triangular port, thus increasing the opening for the escape of brake-cylinder pressure to the atmosphere. When the brake-cylinder pressure has blown down to 60 pounds, the port will be closed, shutting off further escape of brake-cylinder pressure to the atmosphere. In service application, the larger portion of the triangular port will permit brake-cylinder pressure to escape to the atmosphere when 60 pounds has been accumulated in the brake-cylinder, thus blowing down the pressure quickly and preventing more than 60 pounds being



accumulated in the brake-cylinder in service application.

*Q.* 68. If a train with a high-speed brake should pick up a car not equipped for high-speed brake service, what should the engine-man do?

*A.* Usually a small safety-valve is supplied by yard inspectors for cars not equipped with the high-speed reducing-valve. Sometimes, however, the car in unusual cases is permitted to go without either a reducing-valve and without a safety-valve, care being taken by the engineer in service applications of the brake not to slide the wheels.

*Q.* 69. When a car that is equipped with an ordinary brake is coupled to a train using the high-speed pressure, what must be done with this car to run it with the high pressure?

*A.* This is answered in the preceding question.

*Q.* 70. How does the pressure developed in the brake-cylinder, with the high-speed brake, with a given reduction, compare with pressure developed with the same reduction made with the ordinary quick-action brake?

*A.* If reductions less than that which will cause a full application of the low-pressure brake is made, the resultant brake-cylinder pressures will be the same with the low-pressure brake as with the high-pressure brake; however, if the reduction made should do more than produce an equalization of the low-pressure brake, the cylinder of the high-pressure brake would have the highest pressure, and would give a greater breaking force.

*Q.* 71. How many full applications with the high-speed

brake can be made before recharging is necessary, and have left as much pressure as is used with the ordinary quick-action brake?

A. The high-speed brake will usually, with proper piston travel, permit of two full service applications and releases and still have sufficient pressure reserved to make an emergency application as great as the 70-pound brake would give when fully charged.

Q. 72. How should the engine-truck or driver-brake be cut out?

A. A suitable arrangement of cut-out cocks should be supplied which will permit of the auxiliary reservoir being cut out when the brake-cylinder is cut out, thus preventing the brake left cut in having too large an auxiliary reservoir-capacity, which would tend to slide the wheels when brakes were applied.

Q. 73. How should both the driver- and engine-truck brakes be cut out?

A. By the stop-cocks arranged for that purpose.

#### STRAIGHT AIR-BRAKE.

Q. 74. On what is the straight air-brake designed to operate, and what extra parts are required on engine and tender?

A. The straight air-brake is designed to operate on the engine and tender alone, and not on the cars of the train. To operate the combined automatic and straight air-brake, extra parts as follows should be supplied: Reducing-valve for the straight air system, set at 45 pounds; an engineer's straight air-brake valve; a double-

seated check-valve for the driver-brake cylinders; a double-seated check-valve for the tender brake-cylinder; a safety-valve, set at 53 pounds, one for the driver-brake cylinders and one for the tender brake-cylinder; and a straight air-brake hose connection between the engine and tender.

*Q. 75.* What should be done to release the brakes when they do not release with the handle of the straight air-brake valve in release position?

*A.* The automatic brake-valve handle should be placed in full release position, then returned to running position.

*Q. 76.* What pressure should be developed in the brake-cylinder by this brake?

*A.* About 45 pounds, as indicated by the adjustment of the reducing-valve in the pipe between the main reservoir and straight air-brake valve.

*Q. 77.* Where are leaks in the train-pipe most likely to occur?

*A.* First, at the hose couplings; second, at the unions in the train-pipe; third, through porous hose; and fourth, at the exhaust-port of the triple valve.

*Q. 78.* What is the leakage groove of the brake-cylinder for?

*A.* To permit pressure going to the brake-cylinder at the improper time to escape to the atmosphere, past the brake-cylinder piston, instead of accumulating there and pushing out the brake system and applying the brake.

*Q. 79.* As a rule, how great a reduction of train-pipe pressure is necessary to insure the brake-piston moving out beyond the leakage groove?

*A.* On a train of a few cars, about 5 to 7 pounds is

sufficient; but on a long train 10 or 12 pounds will be required. This depends also upon the condition of the triple valves and the condition of the equalizing-piston in the brake-valve.

Q. 80. Should the brakes be tested before leaving the terminal?

A. Yes; first by the yard-testing plan to determine the proper piston travel and condition of the brakes, and second, by the engineer after coupling up to be sure that all angle-cocks are open and that the brakes are operative.

Q. 81. What is the proper brake-cylinder piston travel on freight-cars?

A. From 5 to 7 inches is the accepted standard travel.

Q. 82. How is the slack taken up on a tender?

A. With a brake of the equalized type a dead lever is supplied for taking up the slack. On other types, the slack may be taken up at points where holes are provided for connecting-rods in the brake rigging. Some riggings are supplied with turn-buckles for this purpose, but the practice is not considered the best for tenders.

Q. 83. If a brake is stuck and cannot be released from the engine, how would you proceed to release it?

A. Open the "bleeder" cock quickly and close it quickly, thus making a sudden reduction in the auxiliary reservoir pressure, which will allow the greater train-pipe pressure to shift the triple from application position to release position.

Q. 84. What is the proper piston travel for passenger-cars?

A. About 6 inches standing travel.

Q. 85. If, when testing brakes, it is found that one will not apply, what might be the cause?

A. The brake might be cut out by the cock in the cross-over pipe, the auxiliary reservoir might not be charged, or the triple-valve piston and slide-valve might be so corroded that they will not move in response to an ordinary train-pipe reduction.

Q. 86. Can a brake be operated if the retaining-valve is broken off?

A. Yes; the retaining-valve is operated only to hold pressure in the brake-cylinder to prevent a full release of the brake, and has nothing to do with the application of the brake.

Q. 87. With a 70-pounds train-pipe and auxiliary-reservoir pressure, how much of a reduction will be required to apply the brakes fully?

A. About 20 pounds, providing the adjustment of piston travel is as it should be.

Q. 88. Has the piston travel anything to do with the pressure obtained in the brake cylinder?

A. Yes; the longer the piston travel the greater will be the capacity of the cylinder for consuming the auxiliary-reservoir pressure sent to the cylinder, and consequently the lower will be the brake-cylinder pressure. The shorter the piston travel, the less will be the volume in the cylinder into which the auxiliary-reservoir pressure must go, and the higher will be the brake-cylinder pressure.

Q. 89. With all things uniform, what is the highest pressure that can be obtained in full service application?

A. About 50 pounds, with the piston travel adjusted at about 7 inches travel. Emergency application? A. About 60 pounds with a 7-inch piston travel.

Q. 90. Is a greater initial reduction required with a 50-car train than with a 10-car train?

A. Yes; if a service application be made, for the train-line pressure may leak past a poor fitting ring in the equalizing-piston of the brake-valve and on to the top side, thus causing the piston to descend and close off the escape of train-line pressure before the full reduction has been made. If the train be short, the leakage upward past the piston ring into chamber *D* will be less than it will be with a longer pipe, which has a greater volume and a better chance for leakage.

MISCELLANEOUS (AIR-BRAKE).

Q. 91. Explain how a terminal test of the brakes should be made.

A. All train-pipe couplings should be made and angle-cocks opened except the one on the rear of the train, which should be closed. All hand-brakes should be off. The first test made should be for leaks at the hose couplings and other points in the train-line and auxiliary-reservoir connections. A service application of about 10 pounds should be made, and examination be made to learn whether all brakes have applied. Care should be taken that all brakes are cut in. The piston travel should be adjusted on all cars to about 6 or 7 inches. When brakes are released, care should be taken to know if all brakes are off and that the brake-rigging

does not foul at any point on the truck or car framings. The retaining-valves should be known to be in operative condition and all handles turned down when not in operation.

Q. 92. What is meant by a running test, and how is this test made?

A. A running test consists of a light application of the brakes by the engineer when the train is pulling out, and before it has gotten up to speed, to be sure that all angle-cocks are open and that the brakes are operative.

Q. 93. At what points on the road should the running test be made?

A. At terminals and at all points where the angle-cocks have been manipulated to take in or set out cars, etc. It is also the rule on some roads to make a running test at points where it shall be absolutely necessary for the brakes to perform their functions, such as on draw-bridges, etc.

Q. 94. When should the brakes be released when making a stop with a passenger train of less than ten cars?

A. Shortly before coming to a dead standstill, to allow the brakes to right themselves, and thus preventing a shock to the passengers. b. Of ten or more cars? A. Brakes should be held on until the train comes to a standstill, as releasing to avoid a shock with a long train will frequently break it in two. A two-application stop should be made, and the brakes be held on with a light second application until the train comes to a standstill.

Q. 95. When should the brakes be released in making a stop with a freight-train?

A. The brakes should be held on until the train comes to a stop, as with a long passenger train of ten or more cars.

Q. 96. Why is it dangerous to repeatedly apply and release the brakes on a long train without giving the auxiliary reservoirs time to recharge?

A. The auxiliary reservoir pressure will become depleted by repeated applications, and the holding power of the brakes be thereby reduced and be insufficient to control the train.

Q. 97. When two engines are coupled together in double heading, which engine should have full control of the brakes, and what should the other engine do?

A. The first engine should do the braking, and the second engineer should close the stop-cock under his brake-valve, and place the brake-valve on lap, thus throwing out of service all his air-brake equipment except the foundation brakes on his engine, which are operated by the leading engine.

Q. 98. In case a hose should burst while on the road, what should the enginemen do to assist the trainmen in locating it?

A. Place the brake-valve handle in full release position, thus causing the escape of air at the bursted hose to manifest itself to the brakemen as quickly as possible, easing the steam-throttle off to reduce speed of the air-pump.

Q. 99. How would you apply and release the brakes on a freight train, when only a part of the train is equipped with air-brakes?

A. A reasonable reduction in the train-pipe pressure



should be made to apply the brakes on the air-cars, and when the slack of the train has been bunched, which is indicated by the pushing forward sensation when the slack is taken up, then the brakes may be applied with greater force if desired. In releasing, the straight air-brake on the engine and tender should be held on while the train-brakes are being released and the slack allowed to run out. This will prevent the slack running out in a manner which will snap the train in two.

*Q. 100.* What precaution should be taken in starting a long freight train with all cars equipped with air-brakes, and in operation?

*A.* The slack should be taken easily until the entire train is stretched, thus preventing a break-in-two, which might occur if the slack were taken suddenly.

*Q. 101.* In releasing brakes on a long freight train, what should the enginemen do to be sure that the brakes have released?

*A.* Leave the brake-valve handle in full release position about as many seconds as there are cars in the train, before bringing the brake-valve handle to release position.

*Q. 102.* How is the slack taken up on the American outside-equalized driver-brake?

*A.* By a slack adjuster feature on the connecting-rod to the bell-crank lever.

*Q. 103.* Are the train-pipe and auxiliary-reservoir pressures equal at all times?

*A.* No. *b.* What time are they equal? *A.* Before the brake is applied, when the triple valve has lapped itself during the application of the brake, and after a

release of brakes when the auxiliary reservoir has become fully recharged.

*Q.* 104. How many applications of the brake are necessary to make a stop with a passenger train, and why?

*A.* The two-application stop is considered the best in modern passenger-train service. The first application should be heavy and sufficient to slow down the train to about eight or ten miles an hour, when the brakes should be released before reaching the point at which the stop is desired, and a second and lighter application should be made to finish up the stop, and should be held on until the train is brought to a standstill. If brakes are released on a long passenger train before coming to a full stop, the slack of the train will run out, and the train be snapped in two.

*Q.* 105. How would you make a stop on a grade with a passenger train?

*A.* By the two-application method, holding on the brake for a second application.

*Q.* 106. Explain the operation of the pressure-retaining valve.

*A.* When the handle of the retaining-valve is turned down it is inoperative. When the handle is turned up in a horizontal position, the free exit for air from the brake cylinder to the atmosphere is cut off and the pressure must pass upward against the weighted valve, which has a resistance of 20 pounds. All over this amount will raise the valve and blow off; but all below that amount will be held in the brake-cylinder.

*Q.* 107. What benefits are derived from the use of the retaining-valve?

A. On mountain grades the pressure retained in the brake-cylinder, by turning up the handle of the valve, will hold the train in check while the auxiliary reservoirs are being recharged for subsequent application of the brake.

Q. 108. Name the defects which cause the retaining-valve to be inoperative.

A. First, defective packing leather in the brake-cylinder. Second, defective union in the retaining-valve pipe. Third, retaining-valve or pipe broken off.

Q. 109. Explain how a stop at a water-tank or coal-chute should be made with a long freight train.

A. The engine should be equipped with a straight air-brake for this purpose. The train-brakes should be used until the speed of the train has been brought down to three or four miles an hour, then released and the straight air-brake applied to cover the last few feet of the distance to the desired stop. If the engine is not equipped with the straight air-brake it would be better, with a long train of all air-braked cars, to stop, holding on the brakes, and to cut off the engine while taking coal and water, as considerable time and damage will be saved by this method.

Q. 110. Do you think it poor policy to reverse the engine while the driver-brakes are applied?

A. Yes; tests have proven this.

Q. 111. Should the train-pipe be blown out before leaving the engine-house?

A. Yes; as cinders or sparks are likely to be gathered in the coupling head or hose.

Q. 112. Are the brakes any more liable to stick after an emergency application than after a service?

A. Yes; as dirt in the train line might work between the emergency-valve and its seat, permitting train-pipe pressure to pass to the brake-cylinder.

Q. 113. If, in making a service application, you notice some wheels slide, do you think it good policy to drop sand to start them turning again?

A. No; a wheel once stopped cannot be started to turning again by sand dropped on the rail, and that process will only cut the wheel worse and make the flat spot longer.

Q. 114. Explain the principle of the duplex governor applied to freight trains.

A. The high-pressure head of the duplex governor is connected direct to the main-reservoir pressure and is usually set for 110 pounds. The low-pressure head is connected to port *f* in the brake-valve, and is set at 90 pounds. When the brake-valve handle is in full release position or running position, the low-pressure head is operative, but when placed on lap, there being no main reservoir in port *f*, the high-pressure head must govern, thus permitting the pump to compress air during the time the brake-valve handle is on lap while making a brake application.

Q. 115. Are the results from shocks on passenger trains likely to be expensive and give the road a bad reputation?

A. Yes.

Q. 116. Do you understand the importance of watching the air-gauge closely?

A. Yes.

Q. 117. When descending a grade, how much should the speed be reduced before releasing the brake to recharge?

A. The speed of the train should be brought down to about 10 or 12 miles per hour before recharging. Frequent recharge is preferable to long runs between periods of recharging.

Q. 118. What is meant by application of the brakes?

A. The operation by which train-line pressure is reduced to permit of triple-valve movement, which will send pressure to the brake-cylinder.

Q. 119. Do you understand that the braking power is considerably more on passenger than on freight cars, and on this account greater care must be exercised in handling them?

A. Yes.

## INDEX.

---

	PAGE
Accidents:	
Broken crank-pin .....	148
Broken driving-axle, frame or tires .....	164
Broken rocker or rocker-shaft.....	142
Broken wheels .....	164
Cylinder-head broken.....	148
Driving-springs broken .....	161
Side-rods .....	149
Throttle .....	152
To cylinder connections .....	146
To running-gear .....	156
To valve-motion .....	125, 142
To various parts .....	368
Trucks .....	163
Adhesion:	
Locomotive .....	262
Air:	
Composition of .....	335
Effect on fire of too much .....	69
Required for combustion.....	335, 290-2
Air-brake:	
First-year's questions and answers on.....	344
Second-year's examination on .....	359
Third-year's examination on .....	395
Anthracite:	
Burning .....	297
Axles:	
Driving, broken.....	164

	PAGE
Ash-pan:	
Purpose of .....	349
Bell-ringer:	
Description of .....	375
Blows:	
Through valves and pistons .....	384
Blower:	
Description and use of .....	336
Boiler:	
Description of locomotive .....	347
Designing .....	303
Explosions .....	119
Feeding the .....	64, 87
Inspection of .....	30
Shortness of water in .....	93
Boilers:	
Anthracite burning .....	117
Blowing-off .....	121
Care of .....	115
Causes of injury to .....	120
Dangers of mud and scale in .....	121
Different forms of locomotive .....	117
Factor of safety of .....	116
Foaming and priming of .....	365
Mother Hubbard .....	118
Over-pressure on .....	122
Precautions against scorching .....	34
Preservation of .....	119
Ross Winans .....	117
Wootten .....	117
Zerah Colburn .....	117
Books:	
Value of studying engineering .....	9
Brakes (See EXAMINATIONS):	
Chatellier .....	216
Carbon:	
Purposes of .....	335
Clearance:	
Too much piston .....	88, 170

	PAGE
<b>Coal:</b>	
Bituminous . . . . .	299
Burning anthracite . . . . .	297
Combustion of . . . . .	334
Ingredients of . . . . .	68, 334
Saving and waste of . . . . .	284
<b>Collisions:</b>	
Of trains . . . . .	157
<b>Combustion:</b>	
And firing . . . . .	334
Chapter on . . . . .	284-304
Gases of . . . . .	335
Principles of . . . . .	285, 290
To effect perfect . . . . .	68
<b>Compound locomotives:</b>	
Characteristics of . . . . .	317b
Power of . . . . .	267
<b>Connecting-rods:</b>	
Angularity of . . . . .	207
Care of . . . . .	167
Functions of . . . . .	168
<b>Crank:</b>	
Attempts to abolish . . . . .	204
<b>Crank-pin:</b>	
Broken . . . . .	148
<b>Cross-heads:</b>	
Securing . . . . .	140
<b>Cut-off:</b>	
Adjustment of . . . . .	245
Advantage of short . . . . .	46
Finding point of . . . . .	244
<b>Cylinder-head:</b>	
Breakage of . . . . .	146
<b>Cylinders:</b>	
Accidents to . . . . .	146
Back pressure in . . . . .	198
Compression in . . . . .	200
Operation of steam in . . . . .	198
Pistons and packing of . . . . .	372



	PAGE
Dampers:	
Loss of heat from bad .....	70
Operating .....	68, 336
Detroit:	
Sight-feed lubricator .....	326-7
Diaphragm-plate:	
Purpose of .....	282
Draft:	
Creating .....	273, 276
Obstructions to .....	83
Draft appliances:	
Chapter on .....	273-283
Driving-boxes:	
Pounding off .....	176
Dry-pipe:	
Bursting .....	151
Eccentric:	
Angular advance of .....	206
Definition of .....	202
Position of .....	134, 203
Setting .....	135
Eccentric-rods:	
Breakage of .....	138
Slipped .....	137
Eccentric-straps:	
Breakage of .....	138
Engine:	
Abuse of .....	393
How to start with train .....	44
Reversed (action of) .....	212
Rough riding .....	183
Engineer:	
Attributes that make good .....	1
Examination for promotion .....	331-430
First duties of .....	37, 362
Learning duties of .....	18
Must be intelligent .....	3
Engines:	
Causes of hard steaming .....	80
Hard steaming .....	79

Engines:	PAGE
Power of steam .....	261
Running worn-out .....	125
Slippery .....	63
<b>Equalizer:</b>	
Broken .....	162
<b>Exhaust:</b>	
Detecting cause of lame .....	137
Warning of .....	129
Watching .....	126
<b>Examinations:</b>	
Chapter on .....	331-430
First-year's general .....	332
First-year's, on air-brake .....	344
For promotion .....	21, 331-430
Second-year's general .....	346
Second-year's, on air-brake .....	359
Third-year's general .....	362
Third-year's, on air-brake .....	395
<b>Fire:</b>	
Management of .....	49
Temperature of .....	52, 295
<b>Fire-boxes:</b>	
Different forms of .....	115, 117, 118, 347
Questions about .....	394
<b>Firemen:</b>	
Bad .....	56
First duty of .....	35, 332
Highest type of .....	51
Learning duties of .....	17
Medium .....	56
Men who make good .....	14
Methods of good .....	55
Methods of promotion .....	21
Misconception of duty of .....	16
<b>Firing:</b>	
Conditions that demand good .....	51
Losses from bad .....	301
Systems of .....	55, 286, 334, 352

	PAGE
<b>Flues:</b>	
Burst .....	123, 377
Leaky .....	86, 377
<b>Fuel:</b>	
Combining elements of .....	288
Gases from burning .....	335
Waste of .....	284
<b>Gases:</b>	
Heat value of fuel .....	300
Velocity of fire .....	293
<b>Gauges:</b>	
Steam .....	93
Watching the water .....	335
<b>Grates:</b>	
Advantage of large .....	343
Burning of .....	36
Defects of .....	85
Methods of shaking .....	53
<b>Heat:</b>	
Converting, into work .....	305
Used in evaporating water .....	306
<b>Igniting-temperature:</b>	
Of fire .....	52, 295
<b>Indicator:</b>	
Steam-engine .....	309-318
<b>Injector:</b>	
Care of .....	104
Elementary form of .....	102
Invention of .....	98
Principle of action .....	99, 103, 391
<b>Injectors:</b>	
Care of .....	106, 107
Efficiency of .....	98
Failures of .....	354
Giffard .....	108
Little Giant .....	112
Metropolitan .....	113
Most common arrangement of .....	105
Nathan .....	111
Operation of .....	353

	PAGE
Injectors:	
Sellers .....	108
Inspection:	
Importance of .....	24, 32, 126
Link:	
Hooking up .....	44, 60
Radius of .....	232
Slip of .....	230
Link-motion:	
Adjustment of .....	229
Chapter on .....	218
Invention of .....	219
Weak points of .....	225
Locomotives:	
Causes of hard steaming .....	80
Essentials of free steaming .....	79
Hard steaming .....	79
Horse-power of .....	261, 265
How to start .....	44
Inspection of .....	24, 32
Learning to keep, in order .....	19
Power of compound .....	267
Running worn-out .....	125
Slippery .....	63
Tractive power of .....	261-4
Locomotive engineer:	
Duties of .....	1
How made .....	12
Increasing duties of .....	4
Learning duties of .....	18
Public interest in .....	3
Lubrication:	
Friction and .....	373
Lubricators:	
Detroit .....	326-7
Michigan .....	330
Nathan's .....	323
Sight-feed .....	319
Triple-feed .....	322

	PAGE
Measurements:	
Scientific .....	289
Michigan:	
Bull's-eye lubricator .....	330
Nathan:	
Sight-feed lubricator .....	323
Nozzles:	
Action of .....	276, 283
Defect of .....	277
Effect of small .....	302
Size of exhaust .....	90
Oxygen:	
Province of, in combustion .....	334
Packing:	
Piston and cylinder .....	372
Petticoat-pipe:	
Adjustment of .....	82
Shape and size of .....	280
Pipe:	
Exhaust .....	278
Leaky steam .....	85
Pistons:	
Clearance of .....	170
Effect of too much clearance .....	88
How to detect leakage of .....	128
Striking point of .....	170
Piston-stroke:	
Events of .....	211
Power:	
Horse .....	261
Tractive .....	261
Pounding:	
Of driving-boxes and wedges .....	176
Of working parts .....	153, 390
Resistance:	
Train .....	261, 270
Rods:	
Adjusting brasses of .....	366-7
Running-gear:	
Accident to .....	382

Running-gear:	PAGE
Importance of understanding .....	160
Safety-valve:	
Purpose of .....	339
Side-rods:	
Adjustment of .....	173
Broken .....	149
Care of .....	167
Keying of .....	175
Purpose of .....	172
Slide-valve:	
Allen .....	192
Influence on, of eccentric throw .....	227
Inside clearance of .....	195
Invention of .....	185
Lap of .....	188
Lead .....	196
Movement of .....	205
Primitive .....	185
Smoke:	
Cause and prevention of .....	337, 351
Smoke-box:	
Extended .....	84, 28 <sub>2</sub>
Length of .....	35 <sup>0</sup>
Smoke-stacks:	
Badly proportioned .....	89
Different kinds of .....	83
Proper dimensions of .....	281
Speed:	
Judging .....	13
Stations:	
Duties of enginemen at .....	72
Precautions approaching .....	73
Stay-bolts:	
Purposes of .....	347
Stresses on .....	119
Steam:	
Advantage of high-pressure .....	47
And motive power .....	305
Compression of .....	200

	PAGE
Steam:	
Conditions of .....	308-9
Curve of expanding .....	314
For converting heat into work .....	305
Heat of .....	332
Journey of, from boiler to cylinders .....	363
Meaning of, used expansively .....	364
Raising .....	33
Velocity of .....	102
Working expansively .....	45
Steam-gauge:	
Principle of .....	333
Steam-pipe:	
Burst .....	144
Sweating:	
Cause of tank .....	373
Temperature:	
Advantage of high furnace .....	52
Igniting .....	52, 295
Of fire-box .....	338
Of injected water .....	101
Throttle:	
Accidents to .....	152
Disconnected .....	149
Time-table:	
Familiarity with .....	76
Tractive power:	
Of locomotives .....	261-4
Train:	
Pulling a passenger .....	78
Resistance .....	261, 270
Rights of .....	72
Running a fast freight .....	42
Signalling .....	285
Speed .....	13
Tubes (See FLUES).	
Valve:	
Throttle disconnected .....	378
Valve-gear (See VALVE-MOTION).	

Valve-motion:	PAGE
Accidents to . . . . .	125, 142, 379
Adjusting Walschaert . . . . .	258
Aids in studying . . . . .	10, 209
Chapter on . . . . .	185
Direct and indirect . . . . .	370
Hawthorne's radial . . . . .	248
Interest in . . . . .	132
Inventing radial . . . . .	247
Inventor of Walschaert . . . . .	249
Locating defects of . . . . .	134
Mason's Walschaert . . . . .	250
Mellen, C. J., on Walschaert . . . . .	251
Melling's radial . . . . .	247
Modern Walschaert . . . . .	251
Noting defects of . . . . .	126
Of fast passenger locomotive . . . . .	224
Setting Walschaert . . . . .	260
Trouble with . . . . .	132
Walschaert, chapter on . . . . .	247
<b>Valves:</b>	
Balanced slide . . . . .	369
How to detect leakage of . . . . .	128
Lap of slide . . . . .	188, 370
Lead of slide . . . . .	196, 370
Safety . . . . .	339
Setting . . . . .	236
Testing the . . . . .	145
<b>Valves and pistons:</b>	
Description of . . . . .	368
<b>Vanclain, S.M.:</b>	
On train resistance . . . . .	271
<b>Velocity:</b>	
Of fire gases . . . . .	293
<b>Walschaert valve-gear . . . . .</b>	<b>247</b>
<b>Water:</b>	
Shortness of . . . . .	93
Temperature of injecting . . . . .	101
Velocity of flow of . . . . .	101



	PAGE
Wedges:	
Care of .....	167
Pounding of .....	176
Setting up .....	180, 366
Wellington, A. M.:	
On train resistance .....	271
Wheel-slipping:	
Causes of .....	61
Work:	
Reporting .....	389