



**A CUTTING.**

THE  
L O C O M O T I V E,

OR

THE STEAM ENGINE APPLIED TO  
RAILWAYS, COMMON ROADS,  
AND WATER.

AND

AN ACCOUNT OF THE  
ATMOSPHERIC RAILWAY.



WITH ENGRAVINGS AND DIAGRAMS.

BY PETER PROGRESS,

AUTHOR OF THE "ELECTRIC TELEGRAPH," "THE RAIL," ETC., ETC.

LONDON:

R. YORKE CLARKE AND CO.,

GRACECHURCH STREET.

M D C C C X L V I I I .

## A D V E R T I S E M E N T.



THE following popular account of the application of Steam to the purposes of Locomotion by Land and Water, pretends to nothing more than accuracy and simplicity. If its perusal gives confidence as to the safe use of the tremendous power of steam, by which travellers in our day are whirled along at the rate of sixty miles an hour; and if, at the same time, the *modus operandi* is clearly revealed, the wish of the Publishers will be answered. The Railway Series is completed by the present treatise, which, in connection with its predecessors, "The Rail," and the "Telegraph," forms a full and interesting account of "Railway Appliances in the Nineteenth Century;" under which title the three parts can be had as a complete volume in handsome cloth binding.

# CONTENTS.



	Page.
Origin and Progress of Steam Locomo- tion .....	i.
Locomotive Engines—Steam Boats ....	xliii.
The Railway Locomotive Engine .....	lxvi.
The Atmospheric Railway .....	lxxii.
Locomotive Engines on a Common Road	lxxiii.



THE  
S T E A M   E N G I N E .

~~~~~

ORIGIN AND PROGRESS OF STEAM LO-  
COMOTION.

Steady and swift the self-moved chariot went,—  
Their way was through the adamant rock.

. . . . . on either side  
Its massive walls arose, and overhead  
Arched the long passage.

SOUTHEY.



**T**ITTLE time, comparatively, has passed since the day when a knowledge of scientific subjects was considered as not only unnecessary to the generality of mankind, but absolutely injurious to their

## ORIGIN AND PROGRESS OF

prospects in life. The farmer laughed at the idea that chemistry could assist him in the cultivation of his land : “ the scientific gentleman who lectured at the Town Hall, may be very clever in his way, but how can he know anything about the growing of turnips or corn—what experience has he ever had ? and what the better should I be if I possessed all his learning ? ” Happily, however, the times have changed ; and the farmer, changing with them, has altered his opinion on the subject. “ My boy,” a London tradesman would have said in those days, “ is to follow my business ; to learn to buy in the best market, and sell for the handsomest profit. What is the use of geometry, or optics, or astronomy, or heaven knows what, to him ? No : teach him to read, and write, and cast accounts, and that is all the knowledge he requires. It was sufficient for me, and it must do for him.”

The World, notwithstanding this prevailing opinion, began at last to think ; indeed it could not do otherwise, for it was no longer in leading strings ; and if it did not think for itself, heaven help it ; and the more the growing-up World thought, the more it discovered an inti-

mate connection between every branch of human knowledge, and that these branches were not so many distinct and isolated subjects, but that they depended on each other, and merely formed portions of one comprehensive whole; and the World found out at last, that science, art, and manufactures, were more closely connected than it imagined. Perhaps this view of the case cannot be better illustrated than by describing the origin and progress of the Steam Engine, and showing how at every step of the advance it made, it called to its aid some branch of scientific knowledge, apparently unconnected with it, but in reality essential to its improvement.

That water could be converted into a vapour called steam, is a fact which must have been known from the time fire itself was first discovered, and it is not unlikely the mechanical power of confined steam may have been frequently observed long before it was ever thought of applying this force to any useful purpose. The first account we have of the application of steam, to any but culinary purposes, dates as far back as one hundred and twenty years before the christian era. Hero,

## ORIGIN AND PROGRESS OF

commonly called the *elder*, a celebrated mathematician of Alexandria, during the reign of Ptolemy Philadelphus, invented a simple rotatory machine, the moving power of which was steam; and it is a singular fact that even at the present day several rotatory steam engines have been patented, the principle of which is precisely the same as that of Hero's. We know that when a bullet is driven out of the barrel of a musket by the gases into which the gunpowder has been converted, a recoil shock is felt, strong or weak, in proportion to the violence of the explosion; so again a power dependent on the same principle, launches the rocket into the air, or whirls round the firework called a "Catherine Wheel."

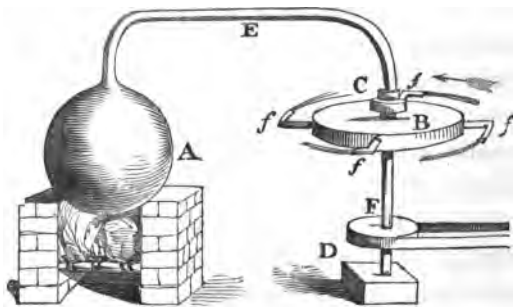

FIG. 1.—HERO'S ENGINE.



## THE STEAM ENGINE.

Fig. 1 will explain in what manner this principle could be carried out by the employment of steam. Let A be a close boiler containing water; this being converted into steam by the heat of the fire placed beneath it, the steam thus formed rushes through the tube E, and fills the flat circular vessel B, which is made in such a manner as to be capable of revolving upon the pivot D, and in the steam tight socket at C. The steam having filled this vessel, is forced through the bent tubes *f, f, f*, &c., which are connected with its interior, and the consequence is a recoil is produced, by which the vessel would be whirled round in the direction of the arrow, as long as the boiler A can supply it with steam; but if a pulley had been placed at F, with a strap communicating with machinery, the pulley would be turned round, and the machinery set in motion with a force greater or less, in proportion to the rapidity with which the steam is forced through the bent tubes.

By this invention of Hero, it was shown that water converted into steam, filled a much larger space than the water itself, and had gained, as we see, a mechanical power, by means of which

## ORIGIN AND PROGRESS OF

it was capable of producing motion in a piece of machinery. Here, however, we must pause for an instant, and examine the other properties of steam, before we can thoroughly understand the mode in which it acts in the Steam Engine.

We have already seen the effects of water when converted into steam in a vessel from which it could escape; but if the boiler A, for instance, instead of being connected with the pipe E, had been firmly closed on every side,—what would have been the consequence? That part of the interior of the boiler which lies above the water would have been soon filled with steam at the heat of boiling water, and this steam would press in every direction upon the interior of the boiler, with a pressure equal to nearly 15lbs. to the square inch. The fire, in the meantime, continuing to impart fresh heat to the water; but as it is the property of water, when in a liquid state, never to rise above the boiling heat, it gives up the heat thus imparted to it to the confined steam, which gradually becomes more and more heated, but at the same time the elastic force, with which it presses again the sides of the

## THE STEAM ENGINE.

vessel, also becomes increased, and that in the following ratio :—

### PRESSURE OF STEAM.

|                                 |        |
|---------------------------------|--------|
| At 212° Farenheit's Thermometer | 15 lb. |
| 250° " .....                    | 30 "   |
| 275° " .....                    | 45 "   |
| 293° " .....                    | 60 "   |
| 510° " .....                    | 750 "  |

Here, then, we have a vast power at our command, if we only knew how to control and economise it.

Enormous as the elastic power of steam is seen to be, there is, nevertheless, a means of increasing that power to an almost unlimited extent, by taking advantage of a law by which all fluids and gases are governed. Unlike solids, which acting simply as weights, merely press in one direction, that is, downwards towards the earth, so that a pound weight can only produce a pressure equal to a pound. Fluids, vapours, and gases, however, acting either by their weight or elasticity, transmit the power in every direction, and consequently increase its effect

## ORIGIN AND PROGRESS OF

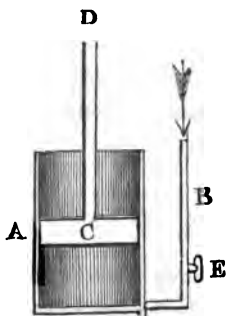

FIG. 2.

Let A, fig. 2, represent the section of a cylindrical box, in which a piston, c, can be moved upwards and downwards, but so nicely fitted in the cylinder as not to allow of the passage of steam between its circumference and the sides of the box. B is a tube communicating with a boiler in which steam is generated, say at the temperature of boiling water, 212° Fahrenheit. The bore of this tube is equal to one square inch, and, consequently, the elastic power of the steam presses downward in the direction of the arrow, with a force equal to 15lbs ; but as steam is governed, as we have already said, by the same law as

## THE STEAM ENGINE.

fluids, it presses in every direction with the same force, and necessarily against the bottom and sides of the cylinder, and the under part of the piston. Now if the area of the under surface of the piston is equal to 50 square inches, the pressure of the steam against it would be equal to 50 times 15lb, or 750lb., and, consequently, it would be able to raise a weight equal to 750lb, placed on the top of the piston rod at D, or to impart a force equal to 750lb to a lever placed at D. Here we have an elastic force of great power, and easily increased.

We have seen how easy it is to impart this elastic force to steam, by merely heating it in a close vessel; but this vapour of water has also another most admirable property: it can, by the application of cold, be almost instantaneously reduced into the state of water again. Let us consider what is the advantage of this property in practice. For the purpose of illustrating a few of the principles of the Steam Engine, we must still refer to fig. 2. We will suppose the steam to have been introduced below the piston c, and to have raised it, so as to have lifted a weight at D, or moved a

piece of machinery placed at the same spot. The return of the steam to the boiler can be prevented by turning the stopcock, E; but this, it is evident, is not sufficient for our purpose, for how are we to get the piston down again? It cannot be accomplished so long as the elastic steam remains pressing against its under surface; but if this steam is suddenly cooled by means we shall presently describe, the water into which it is converted, will occupy a space about 1800 times less than the steam itself did at the heat of boiling water, a vacuum will be formed in the lower part of the cylinder, the piston will be forced down by the pressure of the atmosphere and its own weight, and thus another movement would be imparted to the machinery attached to the piston rod.

The first person who appears to have discovered this rapid method of obtaining a vacuum was Denis Papin, a learned French physician, who flourished at the end of the seventeenth century. It was about the same time also introduced to notice in a more perfect form by Captain Thomas Savary, who, in 1698, obtained a patent for a Steam Engine to raise

## THE STEAM ENGINE.

water. He gives the following account of his discovery :—Having drank a flask of Florence at a tavern, he flung the empty flask on the fire, and called for a basin of water to wash his hands. A small quantity of the wine that remained in the flask began to boil, and steam issued from its mouth ; it occurred to him to try what effect would be produced by inverting the flask and plunging its mouth into cold water. Putting on a thick glove to defend his hand from the heat, he seized the flask, and the moment he plunged its mouth in the water, the liquid rushed into the flask and filled it.

Before this time water had been raised out of mines and other places by the usual laborious method of a piston and sucker, and he imagined that by first filling the barrel of a pump with steam, and then producing a vacuum, by condensing the steam, that the atmospheric air would force the water from the well into the pump barrel, and into any vessel connected with it, provided that vessel were not more than thirty-four feet above the level of the water in the well. He perceived also, that, having lifted water to that height, he might use the elastic force of steam at a high temperature

## ORIGIN AND PROGRESS OF

to raise the same water to a higher elevation, and that the same steam that accomplished this mechanical effect, would serve by its subsequent condensation to reproduce the vacuum, and and draw up more water. "It was on this principle," says Dr. Lardner, "that Savery constructed the first engine in which steam was brought into practical operation."

We have spoken of the atmospheric pressure acting upon the upper surface of the piston, and pressing it down when a vacuum is created at the bottom of the cylinder. This is the power improperly called "suction," and it has been found that a column of atmospheric air of the area of one inch square, will counter-balance a similar column of water thirty-four

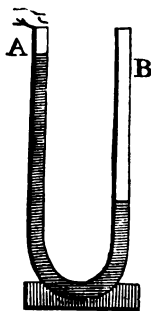

FIG. 3.

feet in height, and weighing 15lbs. It is, therefore, evident, that the atmosphere presses upon all bodies at the surface of the earth with a force equal to 15lbs. to the square inch. To render this natural fact visible to the eye, take a bent glass tube, fig. 3, place the open ends upwards, and fill the tube with



## THE STEAM ENGINE.

water; then place your thumb upon the end A, and pour out a considerable portion of the water from the other leg, you will then see that the water in the leg A will not fall to the level of that in the other leg, nor would it descend in the least, so long as the column of water in it did not exceed thirty-four feet in height; and this arises from the atmosphere pressing on the surface of the water in the leg B, and preventing it assuming a surface level with that in A, or rather the water is unable to descend in A, against the resistance of the atmosphere in B; but if the thumb be removed from it, then the pressure is equal on both surfaces of the water, and it rests at the same level in both the legs. That the atmosphere possesses weight can also be proved in another manner. Take a Florence flask, and having fitted a stopcock to its mouth, let the whole be accurately weighed. The air is then to be exhausted by means of an air pump, and small as the quantity was, there will, nevertheless, be a perceptible difference in the weight of the flask, when it is removed from the air pump and again placed in the scale. The pressure of the atmosphere must, therefore, be considerable, when we consider

## ORIGIN AND PROGRESS OF

that it extends, perhaps, some thirty miles above the surface of the earth.

Thus we see the expansive power of steam at different temperatures; the production of a vacuum by its rapid condensation; and the pressure of the atmosphere, are the three elements with which the inventors and improvers of the Steam Engine have had to work, by adapting these powers to various mechanical contrivances.

These principles being understood, we shall continue to trace the progress of the application of steam. In the sixteenth century, the little instrument, shown in fig. 4,

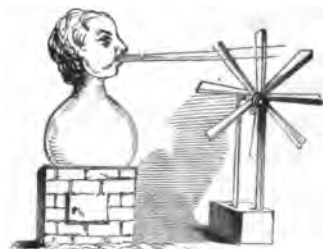

FIG. 4.

was invented. It is another application of the power of steam for the purpose of turning a

wheel by means of a current of vapour issuing from a tube fixed in a hollow ball, partly filled with water and placed over a fire. An instrument or toy similar to this is mentioned in Plot's "Staffordshire." He says, "Yet there are many old customs in use within memory, of whose originals I could find no tolerable account, such as the service due from the lord of Essington in this county to the lord of Hilton, about a mile distant, namely, that the lord of the manor of Essington shall bring a goose every new year's day, and drive it round the fire at the Hall at Hilton, at least three times (which he is bound to do as mean lord) whilst *Jack of Hilton* is blowing the fire. Now *Jack of Hilton* is a little hollow image of brass, about twelve inches high, kneeling upon his left knee and holding his right hand upon his head . . . having a little hole in the place of the mouth about the bigness of a great pin's head, and another in the back about two-thirds of an inch diameter, at which last hole it is filled with water, of which it holds about four pints and a quarter. This, when set to a strong fire, evaporates after the same manner as an æolipile, and vents itself at the smaller hole at the mouth

## ORIGIN AND PROGRESS OF

in a constant blast, blowing the fire so strongly that it is very audible, and makes a sensible impression in that part of the fire where the blast lights, as I found by experience.—May 26, 1680.”

We may, perhaps, be allowed to advert to an employment of steam as a means of deception, if it were only by way of contrast to the present more useful application of the same agent. We are informed that on the banks of the Weser, the god of the ancient Teutones sometimes showed himself unpropitious by a sort of thunder-clap, immediately succeeded by a cloud which filled the sacred enclosure. The statue of the god *Busterich* discovered, it is said, in excavating, pointed out the method by which the pretended miracle was effected.

The god was of metal; the head was hollow, and contained an amphora (about nine gallons) of water; wooden plugs closed up both the mouth and another opening about the forehead; live coals dexterously placed in a cavity of the skull, gradually heated the liquid. Soon, however, the steam generated by the heat, forced out the plugs with a loud report; it then escaped with violence in two streams, and

## THE STEAM ENGINE.

raised a thick cloud between the deity and his stupified worshippers. It would appear that in the middle ages some monks found their account in this invention, and that the head of Buserich has performed its office before other than Teutonic multitudes.

The most remarkable name among the earlier inventors, or supposed inventors, of the Steam Engine, was the Marquis of Worcester, who wrote a work called "The Scantling of a Hundred Inventions." The marquis having taken part with the Royalists against the parliamentary army, was obliged to seek refuge in Ireland on the failure of the royal cause. There he was imprisoned, but escaped to France. From thence, however, he again returned to England, and being again taken prisoner, he was committed to the Tower, where he remained until the restoration of Charles the Second. The story told of the cause that induced him to attempt the application of steam power to mechanical purposes, is as follows:—That, while in prison, he observed that the lid of the pot in which his dinner was cooked was suddenly raised by the vapour of the boiling water: he afterwards, it

## ORIGIN AND PROGRESS OF

is said, remembering this incident, considered whether he might not be able to apply the same power to some useful purpose. The paragraph on which his advocates rely as establishing his claim to priority of invention, is contained in the "Sixty-eighth Invention," and is thus worded:—

"I have invented an admirable and forcible way to drive up water by fire; not by drawing or sucking it upwards, for that must be, as the philosopher terms it, *infra sphaerum activitatis*, which is but at such a distance. But this way hath no bounder if the vessels be strong enough. For I have taken a piece of whole cannon, whereof the end was burst, and filled it three-quarters full of water, stopping and screwing up the broken end, as also the touch-hole, and making a constant fire under it, within twenty-four hours it burst, and made a great crack. So that having a way to make my vessels so that they are strengthened, by the force within them, and the one to fill after the other, I have seen the water run in a constant stream forty feet high. One vessel of water rarified by fire, driveth up forty of cold water, and a man that tends the work has but to turn

## THE STEAM ENGINE.

two cocks, that one vessel of water being consumed, another begins to force and refill with cold water, and so successively; the fire being tended and kept constant; which the self-same person may likewise abundantly perform, in the interim between the necessity of turning the same cocks."

This experiment was made, it is supposed, in the year 1663, and Dr. Lardner observes, that the account is "sufficiently distinct and explicit to enable any one possessing a knowledge of the mechanical properties of steam to perceive the general nature of the machine described."

It seems that after the death of the marquis, the marchioness endeavoured to carry out the project, but she was soundly rated for her presumption by a Romish Priest, who visited her for the express purpose of preventing her from proceeding. "Now, madam," he observed, "how improper such undertakings are for your ladyship, and how impossible for you to effect them, or any of them, all your friends can tell you, if they please to discover the truth to you. The effects," he continued, "are many, as the danger of losing your health

## ORIGIN AND PROGRESS OF

and judgment, by such violent application of your fancies, in such high designs and ambitious desires; the probability of offending Almighty God, and prejudicing your own soul thereby." Nay, the confessor went further than this in his remonstrances, and attributed the lady's conduct to the deeply-laid plots of his Satanic majesty himself. These remonstrances appear to have had the desired effect, and the construction of the *great machine* was never perfected.

About the middle of the seventeenth century, 1651, an anonymous pamphlet was published, of which it has been suspected the Marquis of Worcester was the author. Be that as it may, it most singularly foreshadows the uses to which steam has been applied in later times. The author observes, after acknowledging that although he had sought in vain after the "perpetual motion, and the lessening the distance between strength and time," "yet I have advanced so near to it that already I can, with the strength or help of four men, do any work which is done in England, whether by wind, water, or horses, as the grinding of wheat or rape, and the raising of



## THE STEAM ENGINE.

water; not by any power or wisdom of my own, but by God's assistance, and (I humbly hope, after a sort,) immediate direction. I have been guided in that search to tread in another path than ever any other man that I can hear or read of did tread before me; yet with so good success, that I have already erected one *little engine*, or *great model*, at Lambeth, able to give sufficient demonstration to either artist or other person that my invention is useful and beneficial (let others say upon proof how much more) as any other way of working hitherto known or used."

He then enumerates the multitude of uses to which his invention could be applied, and among others he states, "to draw or hale ships, boats, &c., up rivers against the stream; to draw carts, waggons, &c., as fast without cattle as with; to draw the plough without cattle, &c." "The uses," as he observes, "to which it can be applied, being very difficult, if not impossible, to name at the same time."

Ingenious as many of these ideas were, no real benefit appears to have arisen from their application. At length, thirty years after the

## ORIGIN AND PROGRESS OF

death of the Marquis of Worcester, the first really practicably useful engine was invented, as we have already said. In Savery's engine there was no piston or cylinder. It contained two boilers, the larger called the cistern, supplying the smaller, or steam boiler, while the latter fed the working part of the apparatus with steam. Fig. 5 is a sketch of so much of the working apparatus as will enable the reader

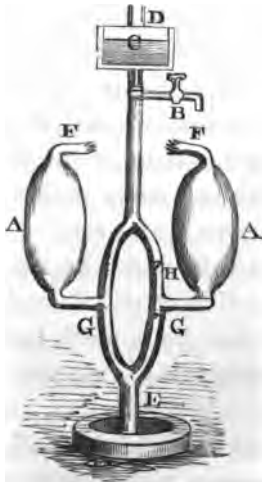

FIG. 5.

## THE STEAM ENGINE.

to understand the mode of action, but it is impossible in this short account to enter into detail.

Fig. 5: A, A, are two iron vessels which are filled with steam from the boiler: B is called the condensing cock, and is in connection with the cistern of cold water C: the arm to which this cock is attached is moveable, so that the cock can be brought over either of the iron vessels, which by means of a series of valves are enabled to act independently of each other: E is the pipe through which the water is raised from the well or mine; and D, the opposite end of the same pipe, by which the water when raised is discharged. Supposing either of the vessels A to be filled with steam, the communication of the supply pipe F is cut off by means of a stop-cock, and a stream of water from the condensing cock condenses the steam in A, a vacuum is created, and the atmospheric pressure on the surface of the water in the well raises it to a certain height in the pipe E. A repetition of the process of procuring a vacuum will at length cause the water nearly to fill the vessel A, and as the steam is again admitted, it presses on the surface of the water

## ORIGIN AND PROGRESS OF

in A, but it cannot drive it back down the pipe E, for a valve at G, opening upwards, prevents its return; the pressure of the steam, therefore, forces the water up the pipe D, where its return is prevented by another valve at H; a vacuum is again formed in A; again the pressure of the atmosphere drives another portion of the water up the pipe E; A is again filled; and its contents once more forced up the discharge pipe C. It is to be observed that the same thing is taking place in both the vessels A at the same time, for they act independently of each other.

In this description of engine, it is evident the three modes in which steam engines work are resorted to. It is a condensing, or low pressure, engine, inasmuch as a vacuum is created by condensing the steam: it is an atmospheric engine, for the pressure of the atmosphere is resorted to as an agent; and it is a high pressure, or more properly, non-condensing engine, since the elasticity of steam is called into play. The chief objection to Savery's engine was the great amount of power and heat uselessly expended.

The necessity for a machine of this descrip-

## THE STEAM ENGINE.

tion, naturally caused an endeavour to be made to overcome the difficulty. A native of Dartmouth, in Devonshire, was the first to effect this improvement. His object was still, however, merely the draining of mines, which he proposed to effect by means of an ordinary pump to be worked by steam power. Instead of employing steam at a great heat and high pressure, he proposed to move a piston in a cylinder by raising it by the elastic force of steam, and depressing it by the pressure of the atmosphere. This engine was, consequently, called an "atmospheric engine."

Fig. 6 will illustrate the principles of the atmospheric engine: A is the pump rod, which is attached by a chain to one end of a working beam at B; the beam moves upon a centre at C. The other end of the beam is attached to the end of the solid rod, D, of a piston, working in the cylinder E. Now if a vacuum be created below the piston, it will be forced down, as we have already shown, by the pressure of the atmosphere, with a force amounting to 15lbs. to the square inch, and the piston of the pump rod would be drawn up the barrel of the pump: the steam, being again allowed

## ORIGIN AND PROGRESS OF

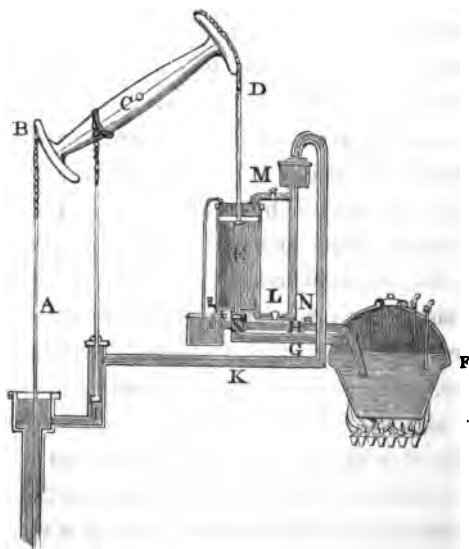

FIG. 6.

to enter beneath the solid piston in the cylinder, would press upwards with the same force, and the piston would be raised, and the pump rod would descend, in the pump barrel, and by this alternate motion, the action of pumping water would be maintained.

In fig. 6, F is the boiler; G the pipe by which the steam is conducted into the cylinder;

## THE STEAM ENGINE.

H a supply pipe, connected with a cistern of water to supply the boiler. To effect the condensation of the steam, the cylinder was placed in an outer case, into which, whenever it was necessary, the pump I pumped water through the bent tube K; and as soon as the condensation was effected, the water was drawn off. But the inventor soon discovered a great improvement in the mode of condensing the steam. A jet of cold water was introduced into the cylinder by the pipe L, and it was found to produce the desired effect much more rapidly. This plan with some modifications is still in use.

In order to keep this engine in work, one man was required to attend to the fire, and another, or a boy, to turn alternately the two cocks, M and N,—N admitting or cutting off the supply of steam to the cylinder; and M allowing the condensing water to enter when necessary. The boys who performed this operation had, it is clear, a very monotonous duty to perform; and it is related that one of these, named Humphrey Potter, an ingenious lad, was tempted by a strong desire to escape from his drudgery, and to effect which he en-

## ORIGIN AND PROGRESS OF

deavoured to discover some contrivance by which he might gratify his wishes. " On observing the alternate ascending and descending motion of the beam above his head, and considering it in reference to the labour of his own hands, in alternately raising and lowering the levers which governed the cocks, (these levers are not shown in fig. 6,) he soon perceived a relation which served as a clue to a simple contrivance by which the Steam Engine, for the first time, became an automaton. When the beam arrived at the top of its play, it was necessary to open the steam valve at *n*, by raising a lever, and to close the injection valve at *m* by raising another. This he saw could be accomplished by attaching strings of proper length to these levers, and tying them to some part of the beam. The levers required to be moved in an opposite direction when the beam attained the lowest point of its play. This he also saw could be accomplished by strings, either connected with the outer arm of the beam, or conducted over rods or pulleys. In short, he contrived means of so connecting the levers which governed the two cocks, as to turn them with the most perfect regularity



## THE STEAM ENGINE.

and certainty as the beam moved upward and downward. This was a great improvement in the engine, and nothing now was needed, excepting, by occasionally turning a cock in the pipe H, to supply the boiler with water.

The atmospheric engine continued much the same in principle for nearly half a century, although the mechanism of the machinery was much improved. At length, in 1736, James Watt was born at Greenock in Scotland, on the nineteenth day of January. He was but a sickly child, but even in his childhood he gave evidence of his future greatness. A friend of his father found the boy one day stretched upon the hearth, tracing with chalk various lines and angles. "Why do you permit this child," said he, "to waste his time so?" Mr. Watt replied, "you judge him hastily. Before you condemn us, ascertain how he is employed." On examining the boy, then six years of age, it was found he was engaged in the solution of a problem of Euclid.

At this time also, he exhibited considerable mechanical skill. One more anecdote, is, perhaps, worth repeating, as it appears to show that even while a child he was thinking of the

## ORIGIN AND PROGRESS OF

subjects that occupied so much of his attention in after life. One day Mrs. Muirhead, the aunt of the boy, reproaching him for what she conceived to be listless idleness, desired him to take a book and occupy himself usefully. "More than an hour has now passed away," said she, "and you have not uttered a single word; do you know what you have been doing all this time?—You have taken off and put on, repeatedly, the lid of the tea-pot; you have been holding the saucers and spoons over the steam; and you have been endeavouring to catch the drops of water formed on them by the vapour; is it not a shame for you to waste your time so?"

It is not our intention to give even a sketch of the life of this celebrated man, but we must notice the incident that directed his attention more particularly to the Steam Engine. Watt had by this time become a mathematical instrument maker, and a model of a Newcomen's engine was sent to him to repair. He noticed its imperfections, and contemplated the improvement of which it was susceptible, but he made no random experiments: he calculated every step he took in his enquiry.

## THE STEAM ENGINE.

The first grand defect discovered by Watt, was the much greater amount of steam introduced into the cylinder to raise the piston than was shown by calculation to be necessary. The steam, it appeared, had its temperature lowered by coming in contact with the sides of the cylinder and the piston, which had been cooled by the introduction of the condensing water. Accordingly it occurred to him, that if the condensation could take place at a distance from the cylinder, the temperature of the latter would not be lowered, and a great saving in fuel would be effected.

To carry out his plan, he applied a pipe A,

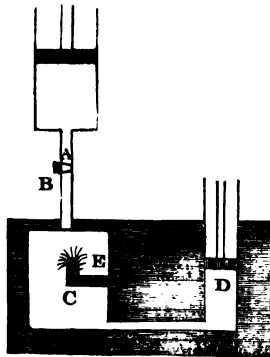

FIG. 7.

## ORIGIN AND PROGRESS OF

fig. 7, to the bottom of the cylinder. This pipe was furnished with a stop-cock, and communicating with a large vessel c, kept cool by being surrounded by cold water. Supposing now that the piston has been raised to the top of the cylinder by the pressure of the steam; supposing, also, that the chamber c is a vacuum, produced by the action of the piston d, which is worked by the engine itself. If, while things are in this state, the stop-cock b is turned, the steam from the cylinder rushes down the pipe a, and is instantly condensed, a jet of cold water from the pipe e materially assisting in the production of its rapid condensation. The cock b, being at the same time turned, to shut off all communication between the cylinder and the vessel c, the piston will be driven down by the pressure of the atmosphere, and the temperature of the cylinder and piston will remain unaltered. This caused a great saving in the expense of fuel, and to render the loss of temperature still more trifling, he next surrounded the cylinder itself with an atmosphere of steam, which kept the outside as well as the inside at a proper temperature.

Another great improvement introduced by

## THE STEAM ENGINE.

Watt, was the employment of steam instead of atmospheric air, for the purpose of forcing the piston to the bottom of the cylinder. This was effected by allowing the steam brought from the boiler to enter alternately above and below the piston, a vacuum being also formed at the same time, at the opposite end of the cylinder ; and thus a machine was made, to all intents and purposes, a Steam Engine, for steam was the only motive power.

It might be imagined that these great discoveries, whose value is at the present day so highly appreciated, would have ensured for their discoverer immediate fame and wealth. Far from it. The invention we have just described, is of the date of 1765. Two years passed away, and he hardly made any progress in attempting the trial of it on a great scale ; and it was not until 1768 he could find any one willing to advance the capital necessary to build an engine of sufficient size. According to his improved plan, in 1769, a patent was obtained for fourteen years, but his partner in the undertaking failed. At length, in 1773, Boulton, of Soho, purchased the share of Dr. Roebuck, and having by great interest and ex-

## ORIGIN AND PROGRESS OF

pense obtained a renewal of the patent, in 1783 Watt again directed the whole of his attention to the improvement of his SINGLE ACTING STEAM ENGINE, as it has since been called. These improvements consisted chiefly in various mechanical contrivances to render the working of the engine more certain and accurate, but did not interfere with the principle of his invention.

It was discovered during the progress of the improvements that took place in the Steam Engine, that an irregularity of motion was produced by the greater or smaller supply of steam afforded by the boiler. To obviate this inconvenience, the fly wheel, so much employed in machinery for the purpose of equalizing motion, was resorted to; but it proved unequal to the emergency. The next invention was the throttle valve, a valve placed in the pipe by which the steam is conveyed from the boiler to the cylinder. The opening and partially closing of this valve either increased or reduced the supply of steam. This valve was moved by the engine man by means of a lever.

Watt, however, soon perceived that the ma-

## THE STEAM ENGINE.

nipulation of the lever would be impracticable with any degree of vigilance and skill that could be obtained from the persons employed to attend on the engine. Accordingly he connected the lever, by which these motions were regulated, with an apparatus, founded on the principle of the regulator employed in wind-mills. To this he gave the name of "the governor," and such is its accuracy that there

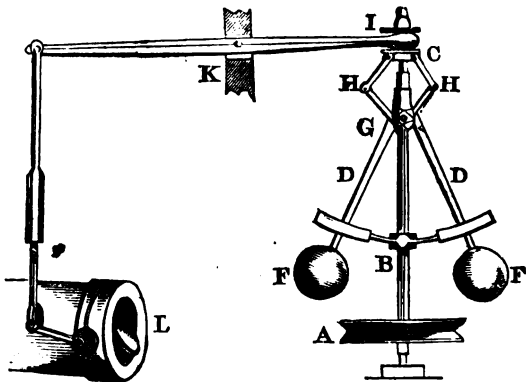

FIG. 8.

was to be seen at Manchester a few years back, in a cotton mill belonging to Mr. Lee, a clock which was set in motion by the Steam Engine used in the works, and which marked

## ORIGIN AND PROGRESS OF

time extremely well, even by the side of a pendulum clock.

To understand the action of the governor, let us refer to the engraving, fig. 8: A is a small grooved wheel, over which an endless cord attached to the machinery runs. This grooved wheel is fixed on an upright spindle B. On this the governor is placed. The levers, D, D, to which the balls, F, F, are fixed, work upon a centre at G. The more rapidly the wheel A revolves, the further will these balls separate from each other, on account of the greater centrifugal power they will then have gained. (The property exhibited by a revolving body to fly from the centre round which it moves, is called the centrifugal power, and is evinced in the most trifling matters on earth; in the twirling of a mop, the flight of a stone from a sling, as well as in the mightiest works of the universe, the motions of the celestial bodies.) As the balls separate from each other, the collar C, which slides on the spindle, is drawn downward in consequence of the angles H, H, being thrust out, and as the collar is attached to the end of the long lever I, which works on a centre at K, it draws down the end nearest to



## THE STEAM ENGINE.

1; and, consequently, raises the opposite end of the lever, by which means the valve L, in the pipe by which the steam is supplied, is turned partly round, and made to offer a greater obstruction to the passage of the steam, and, consequently the machinery will move more slowly. If, on the other hand, the engine were moving slowly, the balls would fall closer to the spindle; the end of the lever near 1 would be raised; and the valve L opened to allow of the passage of more steam to increase the rapidity of the motion.

This variation in the distance of the balls of the governor from the spindle, depends on a power we have already noticed, centrifugal motion, which is exhibited in the tendency of all bodies in motion round a centre, to fly from that centre. The annexed diagram will, perhaps, render the cause of centrifugal motion more apparent.

It is a well established fact that all bodies have a tendency to approach each other if unopposed, and this power, or tendency, bears an exact proportion to the relative magnitudes of the bodies. If we place a moderately sized piece of cork on the surface of the water in a large

## ORIGIN AND PROGRESS OF

bowl filled with that liquid, and then scatter over the water small fragments of the same substance, we shall see that the smaller pieces of cork which are near to the larger piece, will approach the latter and cling to its side. Suppose, then, A, fig. 9, to be the centre, round

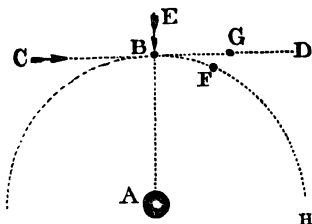

FIG. 9.

which a small body, B, is revolving. This body, we are to suppose, was originally set in motion in the direction C, B, G, D; and, had it not been for the proximity of the body A, it would have continued to move in a straight line until the impetus acquired was exhausted.

But the body A, by its power of attraction, gives to B a tendency to move in the direction E, B, A. Here, then, we have two powers acting on the same body—E forcing B towards A; and the power C, pressing B forward in the

## THE STEAM ENGINE.

direction of G, D. Thus these two powers counteract each other ; but still the onward motion imposed upon B, is not lost : the direction only is changed, and instead of reaching G, as it would if it had continued to move in a straight line, it is bent from its course by the influence of the body A, and reaches F ; and as the two powers still continue to act in the same manner, the original direct course of C, B, is changed into a circular one, B, F, H, &c.

In the instance of the governor, the balls, F, F, have a tendency to fall by their own gravity, while the rods, D, D, attach them to the centre, G, and when they are whirled round, the centrifugal power they acquire by the rotary motion, causes them to diverge, or endeavour to fly off, from that centre, and thus they bring the levers, H, H, and I into action.

Watt soon discovered that the use of the Steam Engine would be much improved if a continuous motion could be produced ; but his Single Acting Engine supplied only an intermitting force, its operations being continued during the descending motion of the piston, but suspended during its ascent. The power

## ORIGIN AND PROGRESS OF

also acted in a straight line, and he required a modification of the machine by which a continuous revolving motion could be produced upon a shaft or wheel.

Speaking of this new improvement, which led the way to the invention of the locomotive engine, Watt himself observes, "Having made my single reciprocating engines very regular in their movements, I considered how to produce rotative motions from them in the best manner, and among various plans that were subjected to trial, or passed through my mind, none appeared so likely to answer my purpose as the application of the crank in the common turning lathe, but as the rotative motion is produced in that machine by the impulse given to the crank in the descent only of the foot, it requires to be continued in its ascent by the energy of the wheel, which acts as a fly. Being unwilling to load my engine with a fly-wheel, heavy enough to continue the motion during the ascent of a piston, I proposed to employ two engines acting on two cranks fixed on the same axis at an angle of  $120^{\circ}$  to each other, and a weight placed upon the circumference of the fly-wheel, at the same angle to each of the cranks,

## THE STEAM ENGINE.

by which means the motion might be rendered nearly equal, and only a very light fly-wheel would be necessary." This and several other contrivances were adopted by Watt to produce a continuous circular motion, but the crank was discovered to be superior to them all.

Notwithstanding all these improvements, however, the power by which the motion was obtained was still intermitting. Watt, to obviate this inconvenience, reverted to his previous invention, by which the piston was moved both upward and downward by the elasticity of steam. This invention we have already described, and engines constructed on this principle were called "Double Acting" Engines. Since this last improvement was brought into practice, no new principle has been brought to bear upon the construction of the Steam Engine, although numerous mechanical contrivances have rendered its action much more certain.

We have already alluded to the application of steam at a high pressure in the working of the Steam Engine, and, in fact, it was one of the earliest applications of steam power, and

formed a part of several of Watt's patents, but it was never fairly brought into practice until 1802, when Trevethick's engine was constructed. The high pressure, or non-condensing engine, is much simpler in its construction than either the single or double action engine. In these last, the motion of the piston is chiefly brought about by producing a vacuum by the condensation of the steam. For this purpose, a condensing apparatus, a good supply of water, and the ponderous beam were indispensable; and, consequently, the engine must occupy a considerable space. In the non-condensing engine, these portions of the apparatus are unnecessary, the piston being raised and depressed by the aid of steam at a high pressure, introduced alternately above and below it. An engine of this description can be so constructed as to occupy but little space; it can also be moved from place to place; and after some improvements had taken place, it became a locomotive engine, not only capable of moving itself, but also of driving the heaviest laden vessel through the water, or dragging with the rapidity of an arrow, the crowded train along the iron rail.

## LOCOMOTIVE STEAM ENGINES

### STEAM BOATS.

With one or two trifling exceptions, the first application of steam for the purposes of locomotion was to the Steam Boat. Although not many years have elapsed since it was applied in this manner with any practically useful result, it appears to have been contemplated as far back as 1737, when a pamphlet was published by one Jonathan Hull, who, in 1736, had obtained a patent for what may be strictly termed a Steam Boat. As this is the oldest claim on record, although it does not appear that it was ever carried into effect, it may be interesting to make an extract from the patentee's description of his invention.

“ In some convenient part of the tow-boat,” he observes, “ there is placed a vessel about two-thirds full of water, with the top close shut. This vessel being kept boiling, rarifies the water into steam, which being conveyed through a large pipe into a cylindrical vessel

## ORIGIN AND PROGRESS OF

and there condensed, makes a vacuum, which causes the weight of the atmosphere to press on the vessel, and so presses down a piston that is fitted into this cylindrical vessel, in the same manner as in Mr. Newcomen's engine, with which he raises water by fire."

"It has been demonstrated that when the air is driven out of a vessel of thirty inches diameter, the atmosphere will press on it to the weight of four tons, sixteen hundred weight, and upwards; and when proper instruments for this work are applied to it, it must drive a vessel with great force." Such was Hull's invention; and the machinery he described for moving a pair of paddle-wheels, was extremely ingenious.

In 1775, a small boat was tried on the Seine, built by M. Perier. It had about the power of one horse, and is said to have been successful, but it was soon laid on one side. In 1781, the Marquess de Jouffray built a Steam Boat, at Lyons, one hundred and forty-seven feet in length, but before the experiment had been fairly tried, the Revolution broke out, and the inventor was obliged to seek refuge in a foreign land.



## THE STEAM ENGINE.

About the same time experiments were going on in America by James Ramsay, of Virginia, and John Fitch, of Philadelphia; in Italy by M. Serratti; and in Scotland by Miller, of Dalswinton. In the latter case an engine was constructed, and put on board a vessel in 1778, and the experiment was so successful that a larger boat was built and tried the following year on the Forth and Clyde canal, but it was laid on one side on account of the great injury it did to the banks.

After this period many were the plans invented to carry out the invention, but with little success. In 1795, Lord Stanhope attempted to propel a boat with paddles resembling the feet of a duck, but the experiment was unsuccessful. Still, however, steam navigation advanced. The Marquess de Jouffray had returned to France, and endeavoured to resume his experiments; but a M. de Blanch had in the interim obtained a patent; while the celebrated Fulton, who was at that time in France, was also busy on the same subject, and soon afterwards returned to his native country—America—where the first really successful attempt was made.

Before he accomplished his task, however,

Mr. Symington, the American Ambassador at the Court of France, obtained a conditional patent, in 1798, dependent on his successfully navigating a vessel by steam in the following year, at the rate of four miles an hour; but being unable to attain the requisite speed, the road lay open for others. Fulton was the most successful of these. Warned by the failure of his partner (for he stood in that relation to Mr. Symington,) he employed a much more powerful engine. This, in 1807, was put on board a boat built for the purpose of running between New York and Albany, a distance of one hundred and twenty miles. After a failure at first starting, which exposed the anxious inventor to the ridicule of the spectators, he got his boat fairly under way, and accomplished the distance in from thirty to two-and-thirty hours. The astonishment and terror of the good people of Albany, when they saw the moving mass approach, was extreme, and is thus described by an American journalist:—

“ She had the most terrific appearance from other vessels that were navigating the river. The first steamers, as many in America yet do, used dry pine wood for fuel, which

## THE STEAM ENGINE.

sent forth a column of ignited vapour many feet above the flue, and whenever the fire was stirred, a galaxy of sparks flew off, and in the night had a very beautiful appearance. Notwithstanding the wind and tide were adverse to its approach, they saw with astonishment that it was rapidly coming towards them; and when it came so near that the noise of the machinery and paddles were heard, the crews, in some instances, shrunk beneath their decks from the terrific sight, and left their vessels to go ashore, while others prostrated themselves and besought Providence to protect them from the approach of the horrible monster, which was marching on the tide, and lighting its path by the fire which it vomited."

A few days only elapsed before Fulton's countryman—Stevens—also launched a Steam Boat with success, but Fulton had obtained an exclusive right to navigating the waters of the State of New York. His competitor, therefore, determined on the bold experiment of conveying the vessel to the Delaware by sea. In this he was successful, and thus he was the first man who navigated the ocean by means of steam.

## ORIGIN AND PROGRESS OF

Leaving our American brethren to improve upon the boats they had already launched, let us turn our attention to Europe, where steam navigation was not introduced until several years later. In 1812, the first Steam Boat was launched on the waters of Great Britain. It was called the "Little Comet," and was built at the Port Glasgow. The engine was only of three horse power, and the vessel had also a great draught of water, both, as it has been since discovered, disadvantageous circumstances for steam navigation. It was soon found that engines of much greater power were required, but, then if you increased the power, it seemed necessary that the size of the engine should be also materially increased, and the room it would then occupy on board the vessel, was more than could be spared. To avoid this increase of size, high pressure engines were employed, but with all the care of the owners, accidents were frequent from the bursting of the boilers. Copper, wrought iron, cast iron, were in turns used in their construction, but it was all in vain; and in America the consequences were more disastrous than even in Britain.

## THE STEAM ENGINE.

In 1817 a dreadful accident occurred by the bursting of a steam boiler in the Norwich river. The vessel was rent to atoms, so that little remained entire from the stem to the engine room, except the keel and the flooring. Twenty-two passengers appear to have been on board. Of these, six alone escaped unhurt, six were sent to the hospital, and the remainder were killed. This and other accidents attracted the notice of Parliament, and a committee sat to inquire into the causes of these disasters. To endeavour to discover a remedy, many plans were suggested, and afterwards adopted; and since that time, accidents of this nature have been very rare in England. Not so, however, on the other side of the Atlantic. There these dreadful occurrences are frequent. A few years back the Editor of an American paper made the following observations on the subject:—

“ In looking over our file of papers for the last six weeks, we find that we have recorded no less than twelve Steam Boat accidents, attended with a loss in the aggregate of more than one hundred lives. They are as follows: ‘ New England,’ boiler burst, 16 lives lost;

## ORIGIN AND PROGRESS OF

‘ St. Martin,’ burnt, 30 or 40 lives lost ; ‘ Capstan,’ burnt, 20 or 30 ; ‘ Illinois,’ boiler burst, 13 or 20 ; ‘ Thomas Yeatman,’ boiler burst, 7 ; ‘ Columbia,’ sunk, 4 ; ‘ Paul Pry,’ boiler burst, 1 ; a total of from 91 to 118 lives lost. ‘ George Washington,’ wrecked ; ‘ Rapid,’ sunk ; ‘ Black Hawk,’ burnt ; ‘ Peruvian,’ sunk ; ‘ Chippewa,’ sunk. Why is it that English Steam Boats are so safe to travellers, and American Steam Boats so unsafe ? Why is it that more lives are lost on board American Steam Boats in one year, than on board English Steam Boats in ten years ? Cannot the difference be partly accounted for by the fact, that in England very strict regulations are prescribed and enforced by the Government in relation to Steam Boats, and in the United States none ? If not, can any man tell how the fact is to be accounted for ? ”

The editor of another paper, published in 1835, observes, “ It has been estimated that 1,500 persons have lost their lives in the United States during the last three years by the bursting of steam boilers.” Let not, our readers, however, be terrified at these alarming statements. They will perceive, when the causes of the bursting of

## THE STEAM ENGINE.

steam boilers are explained, that with the precautions now taken in their manufacture and management, the two principal, nay almost sole causes of these dreadful accidents, can be guarded against with almost perfect certainty. One cause consisted in the boiler not being sufficiently strong to bear the pressure; but at the present day boilers are always made so as to bear a pressure two or three times greater than that to which they are intended to be subjected, and to ascertain that they are capable of bearing this pressure, the boiler is "proved." This is done by filling it with water, and afterwards by means of a forcing pump, causing the fluid to press with the requisite force against the inner part of the boiler. The law by which the pressure of fluids is regulated, we have already explained.

Another element of safety is the application of a safety valve, which being loaded with a certain weight, rises when the pressure from within exceeds that weight, and allows the steam to escape; and so careful are the owners of steam vessels of the safety of their passengers in this country, that, in general, there are two safety valves applied to the boiler, one of

## ORIGIN AND PROGRESS OF

them out of the reach of the engineer, so that he may be unable to tamper with it by overloading it. Here, perhaps, our readers will ask, Is it possible any man can be so careless of his own safety as to risk an accident when he himself would be most exposed to danger if it occurred? Such things are, and some foolhardy men have, although rarely, acted in this manner, for the engineer is as proud of the speed of his boat, as the jockey of the swiftness of his horse, and each of them will, on occasions, risk his own life to excel a rival. But even should this be the case, there is scarcely any danger, for at the present time, scarcely any high pressure engines are employed by the English in steam navigation, and the following evidence, given before a committee of the House of Commons, by Mr. Henry Maudslay, the eminent engineer, shows the almost impossibility of accident when low pressure, or condensing, engines are employed, and at the same time it exhibits the recklessness at times displayed by men for the sake of rivalry, and the danger of the high pressure principle when placed under the control of careless engineers.



## THE STEAM ENGINE.

“ As far as my opinion goes,” he observes, “ I would not go from here to Margate in a high pressure boat, because there are many reasons why that may become much more dangerous, and no more advantageous to the public generally, or to the individuals. A low pressure engine has a very high power ; a high pressure engine has a higher power according to its height of steam. It is pretty well understood that a gentleman who engages in a Steam Boat Company, seldom attends to the engine himself, but leaves it to his men. I built the ‘ Regent ’ Steam Boat last summer, with a low pressure engine. There was a dispute between two men, and one of them swore that he would blow his boiler up but he would beat the ‘ Regent ’ in coming up. The man certainly did exert himself as much as he could, and kept his steam as high as he could get it, and it flew out of the safety valve very frequently ; and he hurt his boiler materially by doing so, but he did not beat the ‘ Regent ; ’ but if it had been a high pressure engine, he would either have beat her or blown up his boiler, because he had the power in his own hand.”

## ORIGIN AND PROGRESS OF

“ Again,” he observed, when asked if the engineer could not fasten down the safety valve in a condensing engine, “ it would be folly to do so, because if the engineer be at all acquainted with his business, he must know that if the steam be raised beyond five or six pounds per inch in a condensing engine, the power of the engine will not thereby be at all increased.” Thus we see that as matters are at present conducted, there is an extremely small risk of danger on board an English Steam Boat. In most steamers of large size, two engines are employed to move the paddle wheels, and in that manner a more steady motion is obtained.

By noticing the accident that occurred in 1817, we somewhat anticipated our accounts of the progress of steam navigation. The “ Little Comet,” as we have observed, first plied for hire on the Clyde in 1812. The river then was a shallow stream, choked up with sand banks, and intersected with rocks; but since that time, by the enterprise of the inhabitants of Glasgow and Greenock, it has been rendered navigable to boats of great burthen, and the Clyde has become celebrated for its river and sea-going boats, for it was not long

## THE STEAM ENGINE.

before the boats ventured into the deep waters of the ocean.

The first Steam Boat that plied on the Thames, was "The Margery," a vessel of seventy tons burden, and fourteen horse power; and soon afterwards, another boat, "The Thames," appeared. The first of these boats went from London to Gravesend in a day, and returned the next. The "Thames," however, promised to convey passengers there and back in the same day.

The appearance of these boats on the river, soon drove out of the field all the passenger sailing packets. Even the much improved Gravesend boats, which left Billingsgate regularly at the time of high water, soon lost all their patronage; and yet the two steamers by which they had been driven out, were but sorry craft, when compared with the passenger boats of the present day. The accommodation was bad, and the clanking of the engine enough to give a nervous patient the headache, while the stench of the foul grease with which the machinery was supplied, had a strong tendency to produce sea sickness even in the smoothest water. Some idea may be formed of the in-

## ORIGIN AND PROGRESS OF

crease of steam navigation by glancing at the following Table, which contains the number of steam vessels registered in some of the principal ports of the United Kingdom in 1845:—

|                      |                                            |
|----------------------|--------------------------------------------|
| London .....         | 261                                        |
| Newcastle .....      | 146                                        |
| Glasgow              | } .....                                    |
| Greenock and         |                                            |
| Port Glasgow         |                                            |
| Liverpool .....      | 70                                         |
| Dublin .....         | 42                                         |
| Bristol .....        | 35                                         |
| Hull .....           | 27                                         |
| Stockton .....       | 25                                         |
| Southampton .....    | 23                                         |
| Sunderland .....     | 21                                         |
| Aberdeen .....       | 18                                         |
|                      | 14                                         |
|                      | <hr style="width: 50px; margin: 0 auto;"/> |
|                      | 682                                        |
| At other Ports ..... | 193                                        |
|                      | <hr style="width: 50px; margin: 0 auto;"/> |
|                      | 875                                        |
|                      | <hr style="width: 50px; margin: 0 auto;"/> |

Great was the alarm created in the minds of the watermen on the Thames by the increase of steam locomotion. Their vested interests were interfered with, and nothing but ruin stared them in the face; but, as in the case of railway travelling, the possessors of

## THE STEAM ENGINE.

the former means of conveying passengers to different parts of the river, soon found that although the business of their rivals had increased to an enormous extent, their own employment was also rapidly extended, and the easy exertion of conveying passengers on board the various steamers amply compensated them for the loss of long fares to Battersea, Chelsea, Putney, and Richmond; and below bridge to Greenwich, Woolwich, or Erith.

There were at this time, and for some years afterwards, regular rowing boats from London to Greenwich, the fare being eightpence, and as they performed their voyage either with or against the tide, the labour was enormous, and the payment insufficient, and yet even these men exclaimed vehemently against the innovation. Their vested rights were interfered with. To make up for supposed losses, the utmost extortion was resorted to; and timid persons were afraid to enter a wherry to be placed on board a steamer. The consequence of this was, the Steam Boat Companies were obliged, in self-defence, to erect numerous piers on the banks of the river, where their passengers were able to embark or disembark.

## ORIGIN AND PROGRESS OF

The certainty and cheap rate at which the public were enabled to travel by the new conveyances, excited an ardour for travelling among the whole community. At first this was exhibited in the formation of pleasant excursion parties to Richmond, or Gravesend, but this was not sufficient; rival Steam Boat Companies put forth all their resources, and, in the first instance, a visit to her Majesty's fleet at the Nore was promised, returning on the same day, and including several hours for recreation at Sheerness.

Soon, however, it was discovered that Margate, and even Ramsgate, could be reached, and the voyagers brought back to their own homes in London, in the course of one summer's day. Did a society wish to take a benefit in aid of its funds, a Steam Boat was hired, and an ample freight of happy souls crowded her decks. Every one enjoyed himself after his own fashion. The religious part of the community, who eschewed dancing and noisy amusement, hired boats on their own account, and passed the time in a manner more congenial to their feelings. The members of Temperance Societies were not behindhand,

but no intoxicating liquors were to be found among their stores, their drink being confined to coffee, tea, ginger beer, lemonade, or a compound called "gingerette," a strong decoction of various spices, the flavour of cloves being predominant; but, alas! for the consistency of the passengers, the smoking of that noxious weed, tobacco, was not forbidden.

Perhaps a visitor from a foreign land, if he wished to gain some idea of the populousness and prosperity of the great metropolis, could not do better than to sail up our noble river on some fine summer's day, and notice the excursion boats and others, as they glide steadily over the smooth waters of the Thames, their masts decorated with colours of various hues, and their decks crowded like ant hills with happy groups of people, while bands of music on every vessel enliven the scene.

The ball was by this time brought into play. A visit to the banks of the Thames was not sufficient, and Rail and Boat united to accommodate the migratory propensities of the multitude. What would our fathers—we will go no further back—have said, if they had been promised a visit to the Isle of Wight, and a re-

turn to their own hearths in London within the space of sixteen hours? They would have looked doubtingly, and considered the matter impossible. Their fathers again would have declared a man was mad, who indulged in such a reverie. Nevertheless the affair has been accomplished, and will no doubt be again effected during our summer months, not *to* the island and back, but *round* it.

It is needless to go into further detail. The Cockney traveller thinks nothing of visiting the Channel Islands to listen to the peculiar French of the Guernsey men, or to go to Calais, but more especially Boulogne, to observe the customs of our mercurial neighbours. It is something to say you have visited the continent, and studied the manners of the people. Some trifling circumstance, however, would not unfrequently prevent the intentions of the traveller being carried into effect, as the following incident will tend to show:—

Two worthy Londoners, smitten with the desire to see foreign lands, determined on a visit to Boulogne. They arrived there in due course, but talking over their amusements in England, the discourse turned upon the



scientific game of "skittles," in which it seems they were both adepts, and as they could not very well agree upon the subject, resort was had to that simple mode of deciding an argument—a bet. One of their fellow passengers had informed them there was an excellent skittle ground at some Anglo-French Hotel in Boulogne.

Being safely landed at their destined port, they proceeded without delay to the skittle-ground, where they found an English lad ready to wait on them. As the day was far spent when they reached their resting place for the night, they were unable to decide their wager before the arrival of bed-time. In the morning the game was concluded, and but just concluded, when the bell of the steamer was heard, and they were obliged to hasten on board lest they should lose their passage, and they thus returned to London bearing with them their experience of foreign travel.

By this time Steam Boats were plying to every part of Europe, and on the Mediterranean. At length two companies started to try what steam could do in crossing the Atlantic. This idea was so bold that half the community

## ORIGIN AND PROGRESS OF

became incredulous. A calculation was made as to the quantity of coals that would be required, and it was clearly shown, on paper, that no steam vessel could carry a sufficient supply. The speculators, however, proceeded to their work, and the "Great Western" and the "Sirius" were built. The "Great Western" was built at Bristol in 1837: it measured 679 tons, was of 400 horse power, 207 feet, 1 inch in length, and 18 feet in breadth. The "Sirius" was built at Leith, in the same year. It was smaller than the rival boat, its measurement being only 412 tons: it was 250 horse power, 178 feet 4 inches in length, and 25 feet 8 inches in width.

The "Sirius" started from Cork on the 4th of April, 1838, and the "Great Western" on the 7th of the same month from Bristol. They started, as we have seen, nearly at the same time, while both of them reached New York on the same day; and on the 28th of April the citizens of that capital were surprised at the appearance of two large steamers in their waters, one of them—the "Sirius"—having been nineteen days on her passage, the "Great Western" having performed the same distance in some-

## THE STEAM ENGINE.

thing less than sixteen days; while the average passage of their fine sailing vessels—the “Liners”—had been thirty-seven.

These large steamers having performed their duty, several others were likewise built for the passage of the Atlantic.

| Where built. | Name.         | Date. | Ton-nage. | Horse power | Lngh on upper deck. | Bredth within paddle boxes. |
|--------------|---------------|-------|-----------|-------------|---------------------|-----------------------------|
|              |               |       |           |             | Feet                | Ft. in.                     |
| London       | British Queen | 1838  | 2,016     | 500         | 245                 | 40 0                        |
| London       | President     | 1839  | 2,366     | 600         | 243                 | 41 0                        |
| Bristol      | Great Britain | 1843  | 1,843     | 1,000       | 274                 | 48 2                        |

The unfortunate “President,” after making several trips in a most satisfactory manner, became due on her return voyage in April 1841, but she was never more heard of. How she was lost was never known, but it has been supposed that she fell in with some icebergs, many of which had broken loose from the northern seas, and were known to be floating about in more southern latitudes. This disaster, however, did not check the enterprise

## ORIGIN AND PROGRESS OF

of the ship builders ; and, in 1843, the " Great Britain," of less tonnage, but of greater length and power, was launched at Bristol. She performed several trips to America and back admirably, but during her outward bound voyage in the autumn of 1846, this magnificent vessel run ashore in Dundrum Bay on the coast of Ireland. In addition to these large Atlantic boats, several others have been built to ply between London and Edinburgh, of more than a thousand tons burthen, and four hundred horse power.

Our Eastern possessions have also been brought within the reach of the giant power of steam ; vessels regularly leaving Southampton twice in every month ; proceeding up the Mediterranean to Malta and Alexandria ; then a short land passage across the Isthmus of Suez brings the traveller to the Red Sea, where a steamer is in waiting to convey him to Bombay ; and this passage from Southampton to Bombay is effected in from thirty-four to thirty-five days, or if he choose to take the benefit of the railways across France, the journey may be performed in about four or five days less !

But still, great as these undertakings have

## THE STEAM ENGINE.

been, greater are in contemplation ; and a scheme is now on foot to establish a regular line of steam packets round the globe itself, by crossing the Atlantic to the Isthmus of Darien, thence a short overland trip is to carry the mail, or traveller, to the Pacific ; from thence to the South Sea Islands and China ; and thence, merely turning one or two thousand miles out of the way, to pay a visit to Australia ! proceed to Hindostan ; up the Red Sea to Suez ; across the Desert to the Mediterranean ; and so back again to the British shores ; and all this is to be effected by the employment of the elastic force of the vapour of a few gallons of water !

Steam Boats of recent construction, as we have already said, have in general two engines to move the paddle wheels, and produce a steady motion. The two following engravings will give a tolerable idea of the internal arrangement of a Steam Boat and its pair of engines.

## THE RAILWAY LOCOMOTIVE ENGINE.

We have already given an account of the rise and progress of railway travelling, the principle on which the power of the Steam Engine depends, and its application to the propulsion of vessels through the water. In the Railway Locomotive, we have no room for enormous boilers, large working cylinders, or an abundant supply of water for the purpose of condensing the steam. Under these circumstances none but the high pressure, or non-condensing, engine can be employed. We want our iron steed, whose heart is flame and life breath steam, to be strong, compact, and active. A mile a minute will surely not hurt his sturdy frame; but to turn the wheels on which he moves along, the piston must not be idle: short and quick must be its stroke, and a supply of elastic steam must be constantly maintained to feed its small but insatiate cylinder.

To effect all this, some alteration was neces-

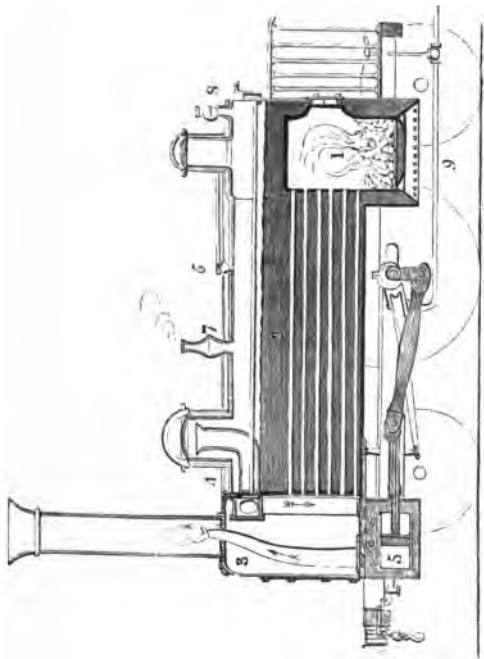

SECTION OF THE STEAM ENGINE.





## THE STEAM ENGINE.

sary in the construction of the boiler. In the first place, as the steam was to be at high pressure, it would have been dangerous to have had a boiler of the usual form, for, in case of accident, the mischief would be very extensive. Such a boiler, also, would have been unable to supply steam with sufficient rapidity to feed the cylinder in which the piston works. Accordingly the boiler is intersected by numerous small tubes, as seen in the section of the Steam Engine. Through these tubes the hot air from the furnace 1, is conveyed. This air, in its passage through the tubes, acts upon a large surface of the water of the boiler, which it quickly raises to the boiling point; and, in this manner, the steam is more rapidly generated. The grating of the furnace being also open to the air, a quick draught is produced. In some instances these tubes are considerably more than one hundred in number, the external diameter of each not being more than  $1\frac{5}{8}$  each. The steam thus generated passes in the direction of the arrow in the cylinder, or piston box 5, where it is introduced alternately at each end of the piston, which, it will be seen, moves horizontally, and having thus performed its

## ORIGIN AND PROGRESS OF

office, it escapes up the tube  $\S$  into the chimney. The alternating motion of the piston moves a crank attached to the axis of the wheel, and in this manner the Locomotive Engine is driven along with inconceivable speed. A smaller vehicle is attached to the engine called a tender. This contains water, and coke for the engine fire, which is attended to by the stoker, while the engineer regulates the speed of the locomotive or stops it in its course when necessary.

The velocity with which an engine moves depends on the rate at which it is possible to move the pistons in the cylinder, (there are two pistons, one on each side the carriage). By every motion of each piston backwards and forwards, one revolution of the wheels is produced, and by each revolution of the wheels, supposing them not to slip on the rails, the engine advances a distance equal to their circumference. As the two cylinders work together, it follows that a quantity of steam, sufficient to fill four cylinders, supplied by the boiler to the engine, will move the train through a distance equal to the circumference of the wheels, and in accomplishing this, each piston must move twice from end to end of the cylinder; each

## THE STEAM ENGINE.

cylinder must be twice filled with steam from the boiler; and the steam must be twice discharged from the cylinder through the blast pipe into the chimney.

If the wheels be five feet in diameter, their circumference will be fifteen feet seven inches. To drive a train with a velocity of thirty miles an hour, it will be necessary that the engine should be propelled through a space of forty-five feet a second. To accomplish this with five-foot wheels, therefore, they must be made to revolve at the rate of three revolutions to a second, and as each revolution requires two motions of the pistons in the cylinders, it follows that each piston must move three times forwards and three times backwards in the cylinder in a second; that steam must be admitted six times a second, from the steam chest, to each cylinder, and discharged six times a second into the blast pipe from the cylinder. The motion, therefore, of each piston, supposing it to be uniform, must divide a second into six equal parts, and the puffs of the blast pipe in the chimney must divide a second into twelve equal parts.

It is evident that such rapid movements as

## ORIGIN AND PROGRESS OF

these, would be the cause of great wear and tear to the machinery. Attempts were, therefore, made to remedy the defect, and to obtain greater speed with an equal, or diminished, rate of motion. To accomplish this, wheels have been employed five feet and a half, or six feet, in diameter; and, in some instances, even ten-foot wheels have been made use of, but these last, we believe, have not proved so successful as it was anticipated.

We have already shown that the boiler of a locomotive engine is formed of a series of tubes for two reasons, one of which is safety, for if by any accident one of these tubes should burst, the damage likely to ensue would be but trifling, and a new tube could be easily inserted in the place of that which was rendered useless. But, as if to make assurance double sure, the tubular boilers of locomotive engines are also furnished with two safety valves, one of which is locked up, and, consequently, out of the reach of the engineer.

At that extremity of the engine at which the engineer stands, is placed the whistle, whose shrill and startling sound is so frequently heard, rousing the sleeper from his

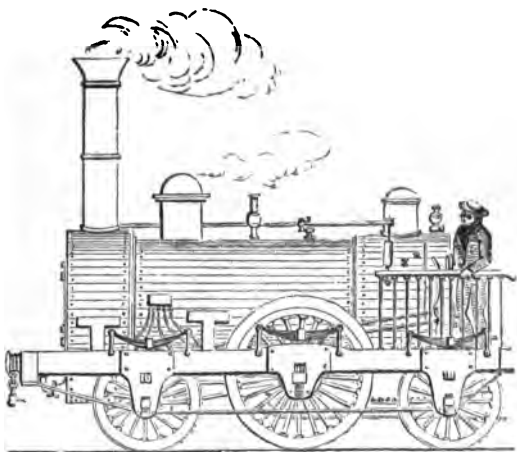

**STEAM ENGINE.**



## THE STEAM ENGINE.

rest, and startling, at times, even the most stoical traveller. Fig. 10 represents this part

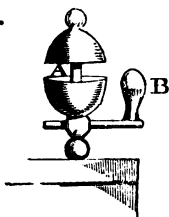

FIG. 10.

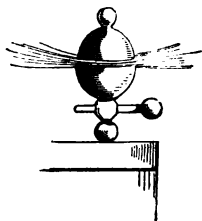

FIG. 11.

of the apparatus when not in action. It consists of two hemispheres of brass; the upper, which is solid, being attached to the stem A, while the lower cylinder is partially hollow. By turning the handle B, the upper hemisphere is brought close to the lower as in fig. 11, and the same motion allows of the escape of steam, which rushing between the edges of the two hemispheres, produces the shrill sound with which we are all so well acquainted.

## THE ATMOSPHERIC RAILWAY.

Hitherto we have described the Steam Engine as employed in dragging a train of carriages along a railway, in the same manner as a horse might perform the same task, but a new description of railway has been constructed within these few years, called the "Atmospheric Railway." On railways of this construction, the moving power is the pressure of the atmosphere, which acts upon a kind of travelling piston, in a long tube with a groove, a vacuum being created in front of it by the exhaustion of the air. This is effected by a powerful air pump, worked by a stationary engine. As the carriage passes, it raises a valve by which the groove is covered, and rendered air-tight. As soon as it has passed, the valve again falls down. It is covered with an adhesive substance, easily melted by the application of heat; and to cause it to melt, and again seal the tube hermetically, a small vessel, containing hot coals, travels



## THE STEAM ENGINE.

along with the carriage. The first Atmospheric Railway was established between Kingstown and Dublin; and another was laid down between New Cross and Croydon, but this latter has been for some time discontinued. It is said that the carriages move at a more rapid rate along an atmospheric tube, than when drawn by engines on a railway.

---

## LOCOMOTIVE ENGINES ON A COMMON ROAD.

The construction of a railway, as we all know, is an undertaking requiring an immense outlay, and it occurred to the speculative mind of Mr. Goldsworthy Gurney, a medical gentleman and scientific chemist of Cornwall, that Locomotive Engines might be so constructed as to draw carriages along a common road. It is true greater power would be requisite to draw an equal load, but then the expense of the railway would be saved. Accordingly Mr. Gurney began the construction of his engines.

## ORIGIN AND PROGRESS OF

These he intended to manufacture as light as he possibly could make them; but imagining that under such circumstances the bite, or adhesion, of the wheel to the ground would not be sufficient to propel the carriage, he went to a vast deal of trouble and expense in the contrivance of levers and propellers acting on the ground, something after the manner of a horse's foot, to drive the carriage forward. As soon, however, as he had fairly started his engine, he found that the adhesion of the wheels to the ground, was quite sufficient, not only to propel the carriage on level roads, but even to enable it to pass over hills of no trifling elevation. In this manner he ascended all the hills between London and Barnet, London and Stanmore, Brockley Hill, and even old Highgate Hill.

It was very clear a large boiler was less able to be used in this description of engine than in any other, and accordingly various plans were resorted to. To effect rapid generation of steam, the water was exposed to the action of the fire in narrow tubes, or between plates of metal placed close to each other; nay, the very bars of the grate were hollow, and afforded their quota of steam. There is one curious fact

## THE STEAM ENGINE.

connected with Mr. Gurney's boiler which deserves notice, showing as it does the advantage of the knowledge of chemistry even in the construction of a boiler.

The small tubes of which we have spoken, on account of the intense heat by which they are surrounded, soon become filled with steam bubbles. Now, if these tubes were horizontal, the steam might ultimately nearly fill the tube. To prevent this, the tubes are placed in a slanting position, so as to allow the steam bubbles to rise through the water without opposition. Perhaps it may be asked, what mischief would have arisen if the steam had remained in the tubes? The water being driven out by the steam, the pipe would have become red hot; and it is a well known fact that water, when exposed to an intense heat, is decomposed, changed into its original elements, two gases, oxygen and hydrogen, and these two gases being thus separated, become highly explosive, and hence arises the danger of allowing the steam to fill the tube.

By a very ingenious contrivance, the engineer when he brings his carriage to the foot of a hill, is able to increase the pressure of the

## ORIGIN AND PROGRESS OF

steam to an enormous extent, for while the usual pressure on the piston is not more than from 30lb. to 40lb. on the square inch, he has a supply at command equal to from 100lbs. to 200lbs. Several other projectors of steam carriages for common roads also appeared. Among which, the most successful were Messrs. Maudslay and Field, Colonel Macerone, and Mr. Scott Russell. The difficulties, however, that stood in their way, were numerous. It was supposed that the wheels of these steam engines would cut the roads to pieces; that horses would be frightened; and that the boilers must inevitably burst. One of their real difficulties was the heavy tolls imposed by Government; and at length, after the expenditure of much money, and many not unsuccessful experiments, steam carriages ceased to appear on the common roads.

We have now shown our readers how the power of steam, in the first instance, like a giant chained, was compelled to raise the water from the bowels of the earth. Soon, however, although still bound down, it set in motion the most complicated machinery. At length, freed

## THE STEAM ENGINE.

from its chains, the giant lightly sprang into the fast sailing boat, and plied his oars so lustily that the sailors hauled down their useless sails, and looked on with wondering eye. But see again, he has usurped the land, and train upon train of heavily laden carriages are hurled along the iron rail with a rapidity enough to make the gazer giddy.

Where next shall we see the monster steam? Will he hold out the hand of fellowship to the aeronaut, and mounting into the sky along with him, thus complete his triumph by lording it over water, earth, and air? Who knows?

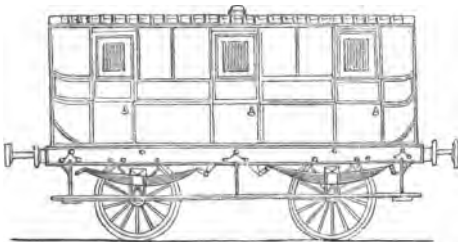



**INTERIOR OF A STATION.**