

# WONDERS AND CURIOSITIES of the RAILWAYS



# WONDERS AND CURIOSITIES

OF THE

# RAILWAY

OR

STORIES OF THE LOCOMOTIVE IN EVERY LAND

BY

WILLIAM SLOANE KENNEDY

AUTHOR OF "JOHN GREENLEAF WHITTIER: HIS LIFE, GENIUS, AND WRITINGS," ETC.

SECOND EDITION.



CHICAGO  
S. C. GRIGGS AND COMPANY  
1884

COPYRIGHT, 1884,

By S. C. GRIGGS AND COMPANY.



## ACKNOWLEDGMENTS.

---

**A**LTHOUGH, in the preparation of the following work I have drawn upon the entire literature of the railway during the half-century of its existence, and am therefore under obligation for materials to innumerable books, magazines, and newspapers, I must yet acknowledge especial indebtedness to the "Railway Age," of Chicago; to files of the London "Times," and certain early American newspapers kindly placed at my disposal by the librarian of the Boston Athenæum, Mr. Charles A. Cutter; and to Mr. William H. Brown's "History of the First Locomotives in America." Mr. Brown's book is standard authority on the subject of early American railroads, although it has been for some time out of print, and is unfitted for the general reader by reason of its technical details. The chapter on "The Vertical Railway," in the present volume, was originally contributed by me to "Harper's Monthly Magazine"; and for permission to use it here, with the accompanying illustrations, I am indebted to the courtesy of Messrs. Harper & Brothers. Special thanks are rendered to Mr. E. H. Talbott, editor of the "Railway Age,"

for the engraving of the George Stephenson passenger-car, that of the old Michigan Central railroad car, the car "Victory," Interior of "Railway Age" car, and several others. Messrs. Hoopes and Townsend, of Philadelphia, have placed in my hands for use the quaint picture of "Old Ironsides," with his

"Train of cars behind, obedient, merrily following";

and Messrs. H. K. Porter and Company, of Pittsburgh, have kindly furnished an electrotype of their logging train. Mr. Thomas A. Edison and the Leo Daft Electric Light Company have furnished views of their electric locomotives. To the "Scientific American" I am indebted for the use of several cuts; also to Mr. John Stevenson for permission to reproduce the engraving of his first street car. The train of cars figured on page thirteen is a reduced fac-simile of the large folded picture that forms the frontispiece to the original edition of Thomas Gray's work on the railway (London: 1823). The picture is, of course, an ideal one, for when it was made the railway was not in existence.

W. S. K.

# CONTENTS.

---

## CHAPTER I.

INTRODUCTION . . . . .	1-6
Sidney Smith and the Solan Goose, 1. The Womb of the Dragon, 2. Balaklava-charge of the Locomotive, 2. Poetry of the Train, 3. Anecdote of the Ameer of Afghanistan, 3. The Railroad a Good Democrat, 3. The Feats of Steam, 3. From Cologne to London, 4.	

## CHAPTER II.

BEGINNINGS IN EUROPE . . . . .	6-30
“Grasshopper Engines,” 6. The Cornish Monster and the Clergyman, 6. “Na-noth-nothing to pay, my de-dear Mr. Devil!” 7. Road-engines with Legs, 8. “Owd Neddy’s Quaker Line” (the Stockton and Darlington), 8. First Railroad Passenger Car in the World, 9. First Steam Passenger Car (George Stephenson’s), 10. The “Puffing Billy” and the Burning-glass, 12. Quaint Early Signals, 12. The Darlington Jubilee of 1875, 12. The Railroad Train of Thomas Gray, 14. Snapped Legs and Bursting Hearts, 15. A Thrill of Annihilation! 16. Downfall of the Bonifaces, 16. Eating a Stewed Engine-wheel, 16. George Stephenson before the Parliamentary Committee,—Roars of Incredulous Laughter, 17. Stephenson’s Victory at Rainhill, 18. Opening of the Liverpool and Manchester Railroad,—	

The First Railway Accident, 18. Fanny Kemble's Locomotive Ride with Old Northumbrian George, 19 (note). The First French Railway,—“*Triomphe merveilleuse!*” “*Plaisir inconnu!*” 20. A Grouty Englishman, 21. Old Samuel Breck of the Corps of Silver Grays, 23. Railway Mania of 1836, 23. “Wily, Slily, Gammon and Bubble!” 24. Railway Mania of 1844, 24. Spinsters and Scrip, 25. Speculations of a Fascinating Marchioness, 26. The Debate of the Crack Engineers, 28. Railway Magnate Hudson and his “Umbrageous Scrip,” 28.

## CHAPTER III.

## THE FIRST AMERICAN RAILROADS . . . . . 30-68

Oliver Evans's Steam-wagon on Wheels, 30. His Remarkable Prophecy, 30. Dr. Darwin's Fiery Chariot, 31. Mother Shipton a Myth, 31. Colonel John Stevens's Railway on Posts, 32. Old “Granite Railroad” of Quincy (first in America), 33. First Snow-plough, 34. First Revolution on American Soil of the Driving-wheel of a Locomotive, 36. Peter Cooper, the “Father of the Locomotive System in America,” 39. Peter Cooper building his Engine, the “Tom Thumb,” 39. Baron Krudener and the Sailing-car, 39. The “*Cowed*” Editors, 39. Race of the “Tom Thumb” and the “Gallant Gray,” 44. The “Flying Dutchman,” 46. A Negro Fireman sits on the Safety-valve of the “Best Friend,” with Unpleasant Results, 46. Silhouette-artist Brown snips out a Quaint Picture of the First Railroad Train in the North, 47. Thundering along toward Schenectady, 48. Wood-sparks, Burnt Umbrellas, and Merry-woful Deck-passengers, 50. Stampede along the Road, 51. Ludicrous Trial-trip of “Old Ironsides,” 52. Old Car, “Victory,” 54. A Novel Track-illuminator, 54. Pounding down “Snake-heads,” 56. Old Custom of Registering Names

of Railway Passengers, 56. The Early Railroads of Massachusetts, 57. Edward Everett Hale's First Locomotive Ride, 57 (note). Thick-headed Legislators, 59. Boston and Worcester Railroad, 59. First Locomotive-whistle in Ohio, 62. The Lexington and Frankfort Railroad in Kentucky, 62. Its Queer Little Locomotive with Hickory Brooms in Front, 63. First Puff of a Locomotive on the Prairies, 65. Charge of a Bull upon the Engine, 66. General Semples and his Prairie-locomotive, 66. View of Old Car on the Michigan Central, 67.

## CHAPTER IV.

## THE BANDING OF THE CONTINENT . . . . . 68-90

Trunk Lines, 68. Colossal Statue of Columbus, hewn out of the Rocky Mountains, 68 (note). "The Strong, Light Works of Modern Engineers," 69. Longest Railroad in the World, 69 (note). First Railroad out of Chicago, 70. Union Pacific,—The Spinning of the Iron Thread, The Steady Tramp across the Plains, The Last Spike, 70. Central Pacific,—The Battle with the Sierras, 71. An Avalanche of Earth, 72. Southern Pacific,—Tank-cars, Red Apaches, Sand-storms, 73. The Mexican Central,—"*Viva la Republica de Mexico!*" 73. The Denver and Rio Grande Railway, the Iron Poem of the West, 74. Railway Exposition at Chicago,—Old Curiosity Shop, Electric Railway, 75. Night-battle with the Indians on the Union Pacific, 78. Anecdote of the Tenderfoot Engineer, 79. Trains running the Fire-gauntlet, 80. Waterspouts on the Plains,—Lost Train, Buried Locomotive, 80. A Wonderful Hail-storm, 80. Snow-ploughs,—Charge of the Harnessed Engines, 82. Trains lost in Snow-storms, 83. The New Time-standard, 87.



## CHAPTER V.

## THE LOCOMOTIVE IN SLIPPERS . . . . . 90-101

The Three-elephant Team in Ceylon, 90. "Change Cars for Nazareth!" 90. The Steam Wagon in the Land of Roses, 90. The Locomotive in the Sunrise Land,—the Mikado opening the First Railroad in Japan, 91. How the "Japs" take to Steam Travel, 92. The First and Only Railroad in China,—Disturbing the Spirits of the Earth and Air, 93. India,—Attack of an Elephant upon a Locomotive; A Military Cordon of Stations; Feathery-foliaged Telegraph-poles; Novel Sleeping Cars; The *Chota-hazare*; The Railroad a Caste-destroyer; Uproar of the Natives at a Station; The "Fragrance of a Monkey-house"; Scarlet Turbans and Grinning Teeth, 94. Africa,—Balconied Cars; Tipped into the Nile; Prayer-carpets; The Imperturbable Old Turk; The *Mish-mish*, 98.

## CHAPTER VI.

## A MOSAIC OF TRAVEL . . . . . 101-114

Russia,—Sumptuous Two-story Saloon-Cars; Clean, Bright Restaurants, 101. Travel in Norway, 102. Sweden,—The Arcadia of Travellers by Rail; Paul du Chaillu and his Wonderful Dinner, 103. Germany,—No Broken Rails; The Conductor in his Little Watch-tower; Five Hours and Fifteen Beers from Cologne to Mainz; The Jolly Buffets, 104. Spain,—Take your Time; "*Quien quiere Agua?*" Fruit Vendors, 106. France,—The Missis of Mugby Junction relates her Travels, "The Universal French Refreshment Sandwich busts on your Disgusted Vision"; Train-lunches, 107. England,—Shadowing a Thief in Woman's Apparel; Features of English Cars; Description of the Underground Railways of London, Gigantic Subterranean and Subfluvial Tunnels, Weird Gliding of the Noiseless Trains, 111.

## CHAPTER VII.

## A HANDFUL OF CURIOSITIES . . . . . 114-125

A Locomotive on Sled-runners, 114. Railroads on the Ice, 115. A Railroad in the Tree-tops, 115. The Old Fremont and Maumee Road, 115. Wooden Railways, 116. Bicycle Railways,—The Steam Caravan at Aleppo; A Two-wheeled Locomotive in New Jersey, 118. Toy Railroads, 118. A Submarine Railway, 119. The Marine Railway of Captain James B. Eads,—Transfer of Ocean Vessels across the Isthmus of Tehuantepec by Rail, 119. Atmospheric Railways (Compressed Air the Motive-power), 120. A Flying Locomotive, 121. Cars Propelled by Sails, 121. A Travelling Telegraph-office, 122. The Dynograph-car, 124.

## CHAPTER VIII.

## MOUNTAIN RAILWAYS . . . . . 125-145

The Locomotive a Good Climber, 125. The Gravity Road of Honesdale,—Magically Propelled Cars, 125. Old Switch-back Road, 126. Old Portage Railroad across the Alleghany Mountains,—“One of the Wonders of the World,” 127. All Aboard for Pittsburgh *via* Horse-car, Canal, and Inclined Plane! 128. Old Mountain-top Track of Virginia, 129. The Mt. Washington Railroad, 129. The Rigi Roads,—Up the Swiss Mountains by Rail, 130. The Mount Desert Railway,—bolted to the Solid Ledge, 131. Up Mt. Vesuvius by Steam-power,—Appalling Steepness of the Track, Cisterns dug in the Solid Lava, Road insured against the Volcano! 132. The Magnificent Tunnels, Viaducts, and Snow-sheds of the Alpine Railroads,—Whirling through Mountains in Corkscrew Fashion,—Cattle as Small as Ants on a Tablecloth,—St. Gothard and Mt. Cenis Tunnels, 134. The Hoo-

sac Tunnel,— History of its Construction, Its Cost, Terrible Accident in the Central Shaft, Five Miles of Solemn Gloom, Torpedo Signals, 138. The Wonder of the Andes Mountains,— A Railroad among the Clouds in the Empire of the Incas, The Highest Track on the Globe; Gorge of *Los Infernillos*, *Tuñel de la Cima*; Thrilling Descent in a Hand-car, 141.

## CHAPTER IX.

## THE VERTICAL RAILWAY . . . . . 145-158

The First Freight Elevators in the World, 146. The Seven Boxes of Sugar and the Air-cushion of Albert Betteley, 147. Otis Tuft's "Vertical Screw Railway" in the Fifth Avenue Hotel, 148. Great Curiosity of Visitors, 149. The Huge Spiral Shaft and its Wheels,—The Brakes and the Fluid-retarder, 149. The First Rope Elevator, 151. Hydraulic Elevators,—Soaring of the Wingless Bird in Paris, 152. The Old Spy-glass Elevators of the New York Post-office, 153. Accidents,—Decapitation of a Negro, etc., 154. The Serio-comic Air-cushion Experiment at the Parker House, Boston, 155. Air-cushion Feats at Chicago Exposition of 1880, 156. The Architectural Grandeur of recent City Buildings due to the Vertical Railway, 156.

## CHAPTER X.

## THE LIGHTNING HARNESSSED—TRAMWAYS . . . . . 158-178

Electricity, the Coming Motor and the Benefactor of the Poor, 158. Around the World in a Train of Flying-cars, 159. Tissandier's Electric Air-car, Paris, 1883, 159. Prof. Werner Siemens, the Father of the Electric Railway System, 159. The First Electric Locomotive in America, 159. The Berlin Roads,—A Horse strikes Lightning with his Shoe, 160. Runaway Car in Paris,—Hop, Snap, Flash! 161.

The Splendid Old Genie at Work in the Mines of Saxony, 161. By Lightning to the Giant's Causeway, 162. Edison's Enchantments at Menlo Park,—His Electric Locomotive, 162. Leo Daff's Electric Locomotive, the *Ampère*, on the Saratoga, Mt. McGregor and Lake George Railroad, 165. The Low-tension Current entirely Safe, 165. Pull of the Electro-magnets, 165. Electric Railways in London, 166. In the United States, 168. The First Street Car, 169. Old Harlem Line in New York, 169. "Whoa!" Crash! 171. The Cambridge Horse Railroad of Massachusetts, 172. *L'Américain*, 172. George Francis Train and his Grand Street-railway Banquet in Liverpool, 172. The Trumpeters of Buenos Ayres, 173. The Cable Railroads, 173. The Elevated Railways of New York, 174. Brick Viaducts of London, 174. Grease Splashes, Burnt Coats, and Rapid Transit, 176. Quaint Report of the Massachusetts Legislators in 1827 on a Bicycle Railway with "Sidelings," 176.

## CHAPTER XI.

## THE FUNCTIONS OF THE RAILWAY IN WAR . . . 178-189

Railways, the Delicate Nerve System of a Country, 178. The Great Railroad Riots of 1877, 178. The Railway a Precarious Reliance when within Reach of the Enemy, 179. A Lacteal Tube for Sherman's Army in its March to the Sea, 180. The *Strade Ferrate* in Italian Wars, 180. The Hospital-trains of Germany, 181. Our Sanitary Commission's Railway Ambulances, 181. The Military Railway Organization of the German Army, 182. The Lack of such an Organization in France, 182. The Practice-railway of the German Corps, 183. General Sherman again,—The Construction Corps during his Atlanta Campaign,—Whistle of the Yankee Locomotive, 184. Story of the Capture of a Locomotive by Twenty-two Picked Soldiers,—Their Wild

Railway Dash, Capture, and Subsequent Adventures, 185.  
An Armored Railway Train in Egypt, 188.

## CHAPTER XII.

## THE LUXURIES OF TRAVEL . . . . . 189-199

Mr. Breck and his Little Jeremiad, 189. The Travelling Coach of Napoleon I, 189. Contrasted with the Imperial Suite of Railway Coaches employed by Napoleon III and the Empress Eugénie, 190. The Travelling of the Queen of Sheba and Queen Victoria,—The Royal Night Train from Windsor to Balmoral, 191. Senator Sharon orders out his Wagon for a Drive over the Continent, 191. Vanderbilt's Flying Palace,—A Hundred Miles in a Hundred Minutes, 192. The "Railway Age" Car a Marvel of Beauty, 193. Invention of Sleeping and Palace Cars by Woodruff, Wagner, and Pullman, 193. The Mann Boudoir Cars, 195. Smoking Cars,—Adventure with Two Feminine Meer-schaums, 186. Speed,—The Fastest Trains of Europe and America, 196. A Train stopped by Mushrooms, 198.

## CHAPTER XIII.

## THE LOCOMOTIVE AND ITS MASTER . . . . . 199-212

"Staym-ingynes, that Stand in Lines," 199. "Grip and Go," the Requisites of a Good Locomotive, 199. Camel-backs and Moguls, 199. English and American Engines Compared, 199. The Crimson Plume of the Locomotive Funnel, 200. A Cunning old Hawk flying in the Smoke, 200. Appetite of the Fire-steed,—Dishes he Eats, 201. Grooming the Locomotive and Oiling up his Joints, 201. The Midnight Ride of an Engine-Cleaner, 202. Asleep on a Locomotive, 203. Trials of Locomotive Engineers, 203. Heroic Death of Engineer Joseph A. Seeds, 204. Railway Yarns

of the West, 205. Chased by a Locomotive, 206. A Locomotive's Tour through a Depot, 207. Fight for an Engine by the Seaside,—A Merry Tug of War, *Steam versus Mules and Men*, 208.

## CHAPTER XIV.

## THE TRACK - - - - - 212-225

The Making of a Steel Rail, 212. Gauges, Broad and Narrow, 213. A Railroad Ten Inches Wide in Massachusetts, 214. Stations, or Depots,—American Barracks *versus* Italian Frescoes and Orange Trees; Fountains, Flowers, Damask Curtains, and Oil Paintings in European Stations, 214. Something about Railroad Signals, 216. The First Telegraphic Signalling (on the Erie Road), 217. An Accident in 1841, 218. The Train-despatcher in his Den, 218. The Block System, 220. Automatic Electric Signals, 220. The Old Train Staff and Ticket System in Great Britain, 221. The Signal and Interlocking Towers and Cabins of London, one of the Wonders of the World, 221. Sixteen Hundred Trains a Day at Clapham Junction, 223. London enmeshed with Labyrinthine Curves, 224.

## CHAPTER XV.

## THE TRAIN - - - - - 225-244

The Manufacture of a Car-wheel,—The Silver-diamond Filaments of the "Tread"; Swinging the Hot Wheels into the Annealing-pits, 225. Paper Wheels, 226. The Miller Coupler, Buffer, and Platform, 226. Description of the Westinghouse Brake, 227. The Baby Elephant and the Air-brake Rope, 228. Invention of the Conductor's Bell-rope, 228. Electric Signal-bells on Cars, 229. Lighting Cars in Europe,—Edison's Incandescent Lamps, and Phosphorescent

Paint, 230. The Eastman Non-freezing Car, 230. History and Description of the English and American Postal-car Systems, 231. Story of the Express-car Business, 232. Railroad Tickets,—their Invention in England, Description of the Delicate and Curious Machinery used in Printing them, First Use in America; Coupon Tickets, first used on the Baltimore and Ohio Road; The Cheap Excursion Ticket, 233. About Conductors,—Fight of a Man with a Railroad, 237. Embezzlements and Spotters, 238. Petty Thieving by Railway Employés in Europe,—Appropriating Wine and Fat Dairy Cheeses, 239. Dare-Devil Train Robbery, 239. "In as Nice a Little Trap as ever I saw," 241. Heigho! a Man inside a Box, 242. Train Robbery in Missouri, 242. Conclusion,—Shortcomings of the Railroad; Its Future, 243.

## LIST OF ILLUSTRATIONS.

---

"THE EXPERIMENT" . . . . .	9
GEORGE STEPHENSON'S PASSENGER CAR . . . . .	11
THOMAS GRAY'S IDEA OF A RAILROAD TRAIN . . . . .	13
FIRST AMERICAN RAILWAY (THE GRANITE ROAD) . . . . .	34
THE "STOURBRIDGE LION" . . . . .	37
PETER COOPER'S LOCOMOTIVE . . . . .	40
THE "BEST FRIEND" . . . . .	45
THE "DE WITT CLINTON" AND COACHES . . . . .	49
FIRST RAILROAD TRAIN IN PENNSYLVANIA . . . . .	53
THE "VICTORY" . . . . .	55
OLD RAILWAY TIME-TABLE . . . . .	60
MICHIGAN CENTRAL RAILROAD CAR, 1848 . . . . .	67
THE "ARABIAN" . . . . .	76
A LOCOMOTIVE ON SLED RUNNERS . . . . .	114
LOGGING RAILWAY TRAIN . . . . .	117
SAILING CAR (KANSAS PACIFIC RAILWAY) . . . . .	123
MOUNT VESUVIUS RAILWAY CAR . . . . .	133
WATERMAN'S ELEVATOR . . . . .	147
THE FIRST PASSENGER ELEVATOR . . . . .	149
EDISON'S ELECTRIC LOCOMOTIVE . . . . .	163
THE DAFT ELECTRIC LOCOMOTIVE . . . . .	167
THE FIRST STREET CAR IN THE WORLD . . . . .	169
ARMORED RAILWAY TRAIN . . . . .	187
INTERIOR OF THE "RAILWAY AGE" CAR . . . . .	193



Brakes were hugged about the wheels,

All the cranks a stillness kept,

Shadows on the polish slept,

And the demon under seals

Quiet lulled the murmuring ire

Of our iron heart of fire,

Till we chafed it into toil,

Gave it blast and gave it oil.

Now we nurse a mad delight,

Dash the iron leagues behind,

Horse a wrath and drink a wind,

Run outrageous through the night.

\* \* \* \* \*

Water boll and fire burn

In the oily steaming urn;

Let the fire and water waste.

They that tarry wind and tide,

Safely to the harbor ride;

Ruin cracks the skull of Haste.

Best though life may be in action,

Action is not all in all;

Till the track is clear for traction

Stand we, though the heavens fall;

Stand we still and steady, though

From the valve the vapor blow,

From the fire the fuel go.

Who shall dare to antedate

By a step the step of Fate?

—E. W. Ellsworth.

# WONDERS AND CURIOSITIES OF THE RAILWAY.

---

## CHAPTER I.

### INTRODUCTION.

Man is become a bird; he can fly longer and quicker than a Solan goose. The mamma rushes sixty miles in two hours, to the aching finger of her conjugating and declining grammar-boy. The early Scotchman scratches himself in the morning mists of the North, and has porridge in Piccadilly, before the setting sun. The Puseyite priest, after a rush of one hundred miles, appears with his little volume of nonsense at the breakfast of his bookseller. Everything is near, everything is immediate.—SYDNEY SMITH.

THE huge, ample-shadowed foundry; the peculiar fragrance of burnt earth and iron; the straight sun-ribbons slanting down from the lantern through the dim-blue smoke; nimbus-rays of gold-colored light bursting out of the blast-furnaces; men passing rapidly to and fro with encrusted ladles of glittering liquor, out of which beauteous gold-sparkles leap upward in many a sprangle and drooping curve; cool earth-moulds licked by tongues of purple fire; the sullen trip-hammer battering the massy cakes of wax-like metal, the changing colors as it cools—pale lemon, gold, red, black; the jet of water applied; the boy controlling the huge steam-hammer that can crack a walnut or shatter a cannon-ball; the deafening clamor of the constructing and finishing room, the hard ring of the resonant iron, the steel ribs, artery-tubes, “the black cylin-

dric body, golden brass and silvery steel," and, finally, the great crane that lifts up the monster in chains, and carries it to the doorway, and sets it down in all the resplendence of its polish and paint, ready to begin its thirty years of toil. This is the building of the locomotive; out of this foundry-womb is born our strong beast of burden, the dusky demon who trundles our errands, on the plains the rival of the bison, in the desert outtiring the camel, among the mountains as sure-footed as the llama,

"Type of the modern, emblem of motion and power,"

perpetuator of democracies, mingler of thoughts and hearts, giver of bread, peacemaker, pet and pride of commerce, patient drudge and bitted dragon of the world.

To four things may the rush of a fast express-train be likened—a hurricane, a prairie fire, the thunder-trample of a herd of wild animals, and the battle-charge of a regiment of cavalry. Hugo gives you the feeling in the storms of his "Toilers of the Sea," and in the charge of the cuirassiers in "Les Misérables." The locomotive has turned our coachmen into heroes—one gain at least; the exchange of leather ribbons for steel has made out of beer-soaken Tony Weller a brave captain; and if the man in blue overalls and black cap is not so jolly and communicative as his predecessor in corduroys and gloves, he is at least sober, faithful and intelligent.

The thrill of wonder that we feel at the sight of the locomotive is partly caused by the circumstance that in it we behold power utilized by a piece of mechanism to transport itself through space, and we generally associate self-locomotion with animal life. That there is a fierce and manly poetry in the make-up and performances of a locomotive nearly everybody feels, though not knowing exactly how to

express the thought. "It is better than a page of the Iliad," says one. "A Balaklava-charge every day," says another. And our old Homeric poet, Whitman, has caught the inspiration of it in his "Locomotive in Winter." There is poetry in the *hum* of an approaching train; in the twisted and braided transparency of the heat as it leaves the locomotive funnel; in the iliacal convolutions and drifted sable of the smoke, and the delicate flushings of the snowy steam as it floats for a moment in wayward indolence behind the train.

But the word "power" expresses more accurately than "beauty" the spirit of the railroad. When Sheer Ali, Ameer of Afghanistan, was taking his first railway journey, and had carefully examined the locomotive, the cars, and the workshops of the line, — "No longer," said he, "can we talk of Aristotle and Diogenes." The Ameer evidently had an inkling of the enormous dynamic possibilities of such an institution as the railroad. But what he would have said if he had stood for an hour at one of the great railway centres of London, and what thoughts he would have entertained in view of the tunnels of the Alps and the Andes, or the astounding railway performances of the United States (in 1882 *eleven thousand five hundred and ninety-one miles* of track were laid in this country), it is impossible to say.

Just what is to be the worth of the railroad as a civilizing factor, it is perhaps too soon to determine. It is quite possible that rapid locomotion may not in any way assist in deepening the humanitarian culture of select coteries of antiquarians and artists, but it is a strong force for the uplifting of the people. The railroad is a good democrat, a great leveller, and that is one reason why old-fashioned æsthetes, like Ruskin, hate it so much. How it intensifies

#### 4      WONDERS AND CURIOSITIES OF THE RAILWAY.

all the activities of society, cuts in two the barriers of sectional and national exclusiveness, weakens caste (notably in India), diffuses the sunshine of intelligence, carries the chopper to the tree, the miner to the mine, the ploughman to the prairie; humbles the haughtiness of the seaport city by placing that of the interior on about the same intellectual level; stretches out the great municipalities into vast areas of rural suburbs;\* carries along its wealthy arteries the golden grain that feeds the world; transports our message a thousand miles and receives a penny in return; conveys our precious packages swiftly and safely; and with the coöperation of the telegraph brings us immediately to the bedside of sick or dying friends.

A fast horse travelling eight miles an hour is burdened by the weight of one man; a locomotive has the draught-power of two thousand horses, and rushes through space at the rate of sixty miles an hour, with a load of a hundred tons, yet feels no fatigue. In the year 1804 it took four days to get from New York to Boston; now it takes six hours. In 1817 it cost one hundred dollars to transport a ton of freight from Buffalo to New York, and required twenty days to get it there; now it takes a few hours and costs a few mills. The twenty thousand locomotives of the United States do the work of forty million horses. The contrast in the matter of speed between travel to-day and travel sixty or seventy years since is well illustrated by a few paragraphs printed in the London "Times" in 1876. In one of the December issues of that year, you may see the letter of an English subscriber, who writes in a high

\*For a valuable *coup d'œil* of the changes wrought by railroads in urban life, see a chapter by Chas. F. Adams, Jr., in the "Memorial History of Boston," entitled "The Canals and Railroad Enterprise of Boston."

dudgeon, because, being in Cologne on Saturday, the fourth day of December, and having invited a party of friends to dine with him in London on the following day, he was actually (owing to some carelessness of the compilers of the official time-tables) delayed with his servants and horses for one hour and fifteen minutes, had his dinner spoiled (and his temper too), and had been obliged to stand in the open air for one hour (probably wrapped up comfortably in the richest furs). Imagine an English gentleman, even as late as the year 1825, writing from Cologne to his friends in London, and inviting them to dine with him at his home in the latter city, on the following day! With what sad forebodings they would have tapped their foreheads, and with what haste the gentleman's afflicted relatives would have made preparation quietly to convey him, on his return, to some private asylum for lunatics!

## CHAPTER II.

### BEGINNINGS IN EUROPE.

THE first steam-locomotives were portentous and uncanny-looking creatures,—resembling nothing so much as gigantic grasshoppers, so thickly covered were they with levers, joints, legs and arms. The earliest locomotives were road-engines, and it may readily be imagined that their first appearance on a lonely road would produce consternation in the minds of the simple-hearted villagers and farmers. In the Patent Museum at South Kensington, London, is preserved one of the earliest locomotive engines, namely that of Murdock, assistant of James Watt. It is one of the “grasshopper” engines. One dark night Murdock was experimenting with his new machine at Redruth, in Cornwall, when, by some accident, it escaped from his grasp and went galloping at a great pace down a lonely lane. Now it chanced that a venerable clergyman was taking an evening walk in this lane, which led directly to his church. Suddenly he saw approaching at a furious rate of speed an indescribable monster, of legs, arms, and wheels, whose body glowed with internal fire, while rapid gasps for breath seemed to indicate that it was suffering the agonies of death. The clergyman’s hair actually stood on end with fear, and, being convinced that a fiend from hell was making toward him, he set up loud cries for help. The inventor soon appeared, however, and assured

the good man that the machine was no diabolical creature, but simply a runaway locomotive.

Coleridge is authority for the following similar story about a road-engine of the Cornish inventor, Richard Trevithick, who in 1804 first applied steam power to the drawing of loads on a railroad:

As Trevithick and an assistant named Vivian were steaming along the road between Plymouth and Camborne, Vivian caught sight of a closed toll-bar just as they had battered down the front rails of a gentleman's garden by rushing against it with their engine. "Captain" Vivian called to his partner to slacken speed; he did so and stopped close by the gate, which was opened like lightning by the gateman.

"What have us got to pay?" asked Vivian, careful as to honesty, if reckless as to grammar.

"Na — na — na — na!" stammered the poor man, trembling in every limb, and his teeth chattering as if he had the ague.

"What have us got to pay, I ask?"

"Na — noth — nothing to pay! My de — dear Mr. Devil, do drive on as fast as ever you can! Nothing to pay!"

The feverish pulsations of the steam-engine quickened the movements of trade; the product of the cotton-mills was doubled; the demand for rapid transit grew more urgent, and numerous and quaint were the mechanical motors devised by sanguine inventors. It was for many years believed that road-locomotives would be the steam-vehicles of the future, and such men as Burstall, Hill, Gurney, Ogle, Summers, Sir Charles Dance, and Walter Hancock gave years of study to the perfecting of their respective machines. Strange monsters went puffing about



the land in those days. In 1813 William Brunton patented a railroad locomotive which was provided with legs and feet that clattered away at the rear of the machine at a great rate. Brunton thought that the wheels would not bite the rail hard enough to draw heavy loads (especially on inclines) without the aid of legs to push from behind. It was not then known that the bite is greater in proportion to the greater weight of the car or locomotive — one of the most important principles in railway mechanics. This device of legs to assist traction was applied by Goldsworthy Gurney to his road-locomotives, which from 1827 to 1835 were in very successful operation in the neighborhood of London, where they ascended the highest hills with ease. In 1831 one of his carriages ran for about four months between Gloucester and Cheltenham; and in 1835 another ran between Glasgow and Paisley. But there were several explosions of these road-engines, and with the rapid growth of the railroad idea, the other method of locomotion gradually dropped out of sight.\*

The story of the origin of the steam-locomotive at the coal mines of Newcastle, its development by George Stephenson, and first application on an extended scale to the Stockton and Darlington coal railroad, has been told so often and so well by Smiles and others, that it would be superfluous to dwell minutely upon it in this work. The Darlington road was projected in 1817 by the Quaker, Edward Pease ("Owd Neddy," as the miners called him), and was often called the Quaker line. It was thirty-seven miles in length, and was opened September 27, 1825.

\* At Maidstone in England, however, there are now in use a score and more of road-locomotives, which do heavy "trucking" over the streets at night when there is no danger of frightening horses.

The road cost six hundred thousand dollars. No passenger traffic was originally thought of, but, there seeming to be quite a demand for a passenger-car, the directors determined to furnish one, and accordingly put upon the road the first railroad passenger-car ever built (called "The Experiment"). It was a rude cabin placed upon four

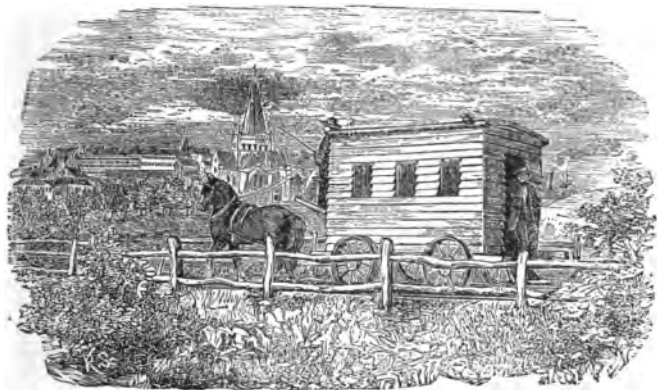

"THE EXPERIMENT."

wheels. A row of seats ran along each side of the interior, and a deal table was fixed in the centre. The passenger receipts for the first year were about three thousand dollars; the annual passenger receipts of all the English railroads at the present time are nearly one hundred million dollars. The first passenger coaches on the Stockton and Darlington road were drawn each by a single horse, while at the same time Stephenson's engines were drawing the coal trains. Afterward the passenger-cars were also drawn by steam-power. The immediate successors of the "Experiment" were two "new and elegant" horse-cars called the "Express" and the "Defence." They were

## 10 WONDERS AND CURIOSITIES OF THE RAILWAY.

coach-bodies on trucks, carried passengers inside and out, had a lever-brake reaching up to the coachman's box, and were in general the prototype of those afterward used on the Albany and Schenectady, and the New York and Harlem railroads in the United States (see Chapter II). From a contemporary Scottish newspaper we learn that, considering that there was formerly no coach at all on either of the roads to which the railway ran parallel, the traffic was thought quite wonderful. "A trade and intercourse has arisen out of nothing and nobody knows how." It is further stated that "at any bends of the road, or other place, when the view is obstructed, the coachman blows a horn to give warning of his approach to any wagons or vehicles that may be coming or going on the way; and in meeting or passing, either the coach or the vehicle goes off into some of the passing places, and then returns into the main line."

On the opposite page is given a profile view of one of Stephenson's steam passenger-cars — a fragile vehicle indeed when compared with the massive cars of our day. The lower hinged doors opened into receptacles beneath the seats used for the stowing of luggage. The picture is copied from a drawing sent to the Boston and Lowell railroad by Stephenson, in 1835. The famous engineer was at that time in the pay of the Boston and Lowell road, and sent over this drawing with a number of others. Mr. J. B. Winslow, of Boston, to whose kindness and that of Mr. E. H. Talbott the author is indebted for the use of the picture, says: "This drawing evidently was copied from one that was used to build the cars from, some years before its date (1832). I have no doubt the original was used for building the first passenger-car ever constructed."

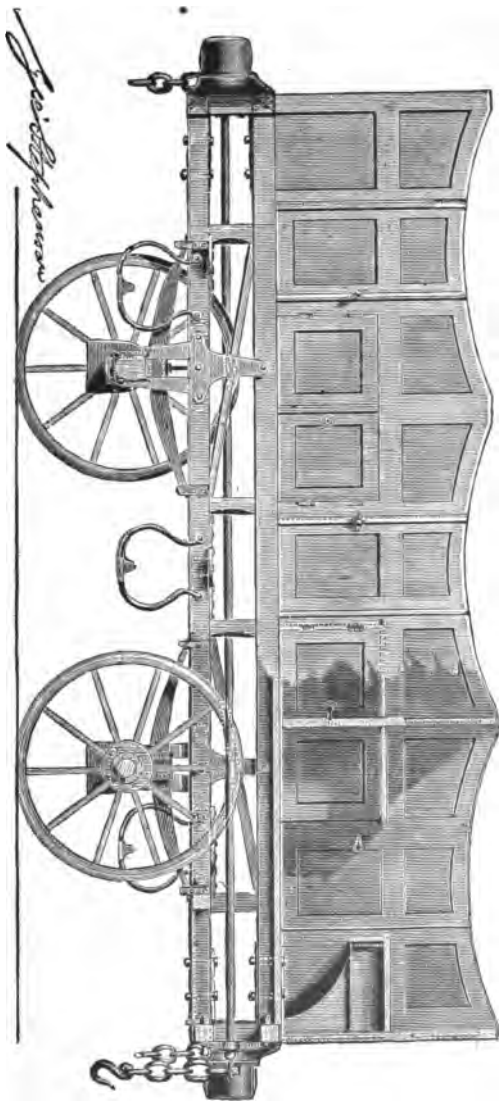

GEORGE STEPHENSON'S PASSENGER-CAR.

The day of the introduction of the steam-engines upon the Darlington road was celebrated by a procession of cars and locomotives, and by general festivities. When the time came for firing up the first locomotive (called the "Locomotion," or "Puffing Billy"), it was found that no tinder-box was at hand. Thereupon one of the employés drew a burning-glass from his pocket, and obtained fire from the sun. This act strikes the mind as highly poetical and appropriate; the power that propelled the engine emanated from sun-made coal, and the fire that liberated the power was also of solar origin. Thus, as the ancients would have thought, the fire was pure and sacred, and with them the act of the English fireman would have taken the shape of a sacred and solemn rite. But times change, and customs with them.

It goes without saying that everything connected with the first railroad was of a rude description. There were no gates across turnpike roads, no brakes on the cars, and no signal-lamps. One kind of night-signal used by an engineer for stopping a train was a burning tow-line kindled by a shovelful of red-hot cinders. A candle stuck in the station window was the signal to stop, and its absence meant "go on." The cars had no springs and no buffers, and the jolting was something awful. The Stephenson locomotives at this time had the steam-blast, but not the multi-tubular boiler.

On September 27, 1875, the semi-centennial of the origin of railways was celebrated at Darlington, under the auspices of the Directors of the North-Eastern Railway Company. One hundred thousand visitors were present at the Jubilee; there were flags and cannon-firings, a banquet

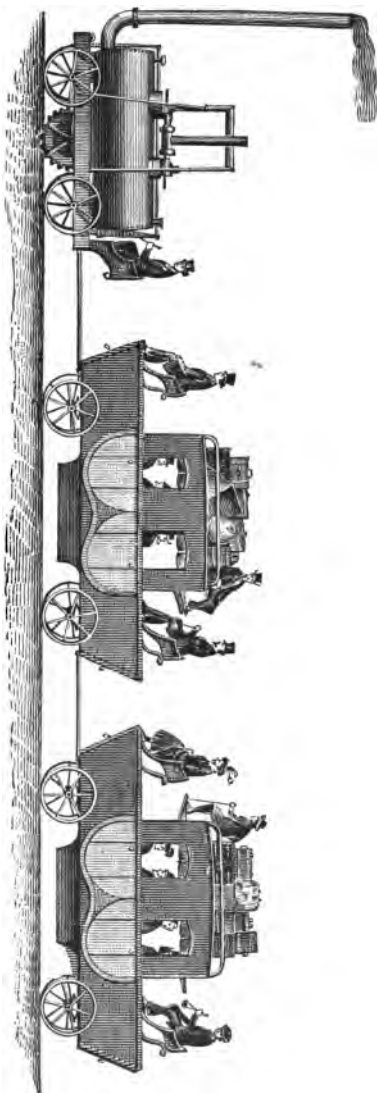

THOMAS GRAY'S IDEA OF A RAILROAD TRAIN.

and speeches, and an exhibition of veteran locomotives, and other quaint relics of the early days.

Before passing to some account of the more famous Liverpool and Manchester railroad, we must not omit a tribute of praise to Thomas Gray, of Nottingham. He was the first to agitate the question of passenger railways. The subject was his hobby, his craze; he memorialized all prominent men, wrote in all the journals, and bored everybody nearly to death. "Put him in a strait jacket," said the "Edinburgh Review"; "Such persons are beneath our notice," said the pompous "Quarterly." Nevertheless, Gray's prophetic work on railways went through five editions during his lifetime, and he lived to see his idea triumphant. But such was the irony of fate that he was refused employment on the very road he had planned and helped to bring into existence, and he "died steeped to the lips in poverty."

It is not generally known that the first railroads of England formed a step in the evolution of means of rapid transportation which was absolutely demanded by the most urgent stress of circumstances. Especially was this true of the Liverpool and Manchester road. The invention of steam spinning machinery had doubled the trade in cotton every twenty years, and, as a consequence, the population of Liverpool and Manchester had vastly increased. But the means of transportation were utterly insufficient. There were three canals, but their day had gone; their charges were enormous, their monopoly odious, and the bearing of their directors haughty and dictatorial. The streets of Liverpool were blocked up with timber and bales of cotton to an incredible extent, and no entreaties of merchants could get them to their factories and mills. It often took

longer to get goods from Liverpool to Manchester (a distance of thirty miles) than it did to get them across the Atlantic Ocean from New York.

Then, too, the demand for fast mail coaches was loud and importunate. Thirty thousand horses were killed off every year in the attempt to make them carry the mails at the rate of ten miles an hour; there are many cases recorded where horses burst the heart, or snapped a leg from being over-driven.\* It was high time for mechanical transit. It was the age of steam, and there was no steam-travel; the incongruity was soon removed, however, and the world saw a railroad-system developed with marvellous rapidity; with unhealthy rapidity, indeed, and feverish speculation, as we shall soon see, but yet, on the whole, to the lasting benefit of the nations concerned.

It is amusing to read the objections that were made to the building of railways, at the time of the agitation concerning the construction of the Liverpool and Manchester road. It was affirmed that the smoke from the engine would kill all the birds; the sparks would certainly set fire to fields and houses; passengers could not breathe in a train going so rapidly, or they would be made worse than sea-sick; the boiler would burst; the railroad would ruin the farmer, kill all the game, and produce premature birth-pangs in women and the lower animals; the sacred

\* Mr. Eames (of the White Horse, Fetter Lane) keeps about three hundred horses; he finds them last three years in post-coaches, and as long again at a distance from London; he says that his drivers represent the "crossing backwards and forwards through the gravel, heaped sometimes in the middle of the roads near London, as tearing the horses' hearts out."—*QUARTERLY REVIEW*.

It appears that the extra demand for coach-horses arises out of the new regulations of the post-office, which cause the death of two horses, on an average, in three journeys of two hundred miles.—*YORKSHIRE GAZETTE*, December 27, 1821.

The average life of the street-car horses of our own day is four years.



game of fox-hunting would be destroyed; and the privileged castes would be mingled with the common herd. Stephenson's tunnel was an object of great dread. It was said that "the sudden immersion in the gloom of the tunnel and the clash of reverberated sounds in a confined space combined to produce a momentary shudder, an idea of destruction, a thrill of annihilation"! (A medical committee was, however, appointed, and they reported tunnels to be in no way injurious to the health.) The poet Wordsworth was furious against the profane innovation, and Ruskin still thinks the railroad to be the invention of the devil. Another seriously urged objection was that thousands of coachmen and innkeepers would be thrown out of employment. There was a grain of sense in this objection. Only a few acrid old fanatics rejoiced in the approaching downfall of the Bonifaces. It is reported that a certain French archbishop declared that railways were an evidence of the divine displeasure against innkeepers; they would now be punished for having supplied meat to travellers on fast-days, by seeing said travellers carried swiftly past their doors.

It is curious to read of the incredulity with which men listened to predictions of a rapid rate of speed in travelling. A prominent Liverpool gentleman said that if it should ever be proved possible for a locomotive engine to go ten miles an hour, he would undertake to eat a stewed engine-wheel for his breakfast. In 1671 Sir Henry Herbert had said: "If a man were to propose to convey us regularly to Edinburgh, in coaches, in seven days, and bring us back in seven more, should we not vote him to Bedlam?" But if Sir Henry had entertained such opinions of a rate of speed like this, what must have been the opinion of conservative old gentlemen of a later day, when told of cars flying

through the air at forty miles an hour? Let one anecdote suffice for many relating to this topic:

When the Liverpool and Manchester railway was under discussion in Parliament, George Stephenson, engineer of the road, was examined by a special committee. The leading counsel of the promoters of the railway was himself a little sceptical about the wonders promised by the then unknown engineer, and cautioned him nervously and earnestly not to claim a speed of over fifteen miles an hour. But a member of the committee, thinking that he could press the simple-hearted witness to an absurdity, cross-examined him to the following effect:

“ Well, Mr. Stephenson, perhaps you could go seventeen miles an hour.”

The engineer promptly answered, “ Yes.”

“ Perhaps some twenty miles might be reached.”

“ Yes, certainly.”

The member thought he had hooked his fish.

“ Twenty-five, I dare say, you do not think impossible.”

“ Certainly not impossible.”

“ Dangerous?”

“ Certainly not.”

“ Now tell me, Mr. Stephenson,” said the inquisitor in a tone of deprecatory indignation, “ will you say that you can go thirty miles?”

The answer was as before, “ Certainly.”

Upon this every member of the committee leaned back in his chair and roared with incredulous laughter. But George built his road, and on the very opening day attained a speed of thirty-six miles an hour.

About a year before the Liverpool road was finished, occurred the famous trial of engines at Rainhill (October

6, 1829). Four engines were entered to compete for the five hundred pound prize offered by the Directors. They were the "Novelty,"—one of the builders of which was Ericsson, afterward constructor of our iron-clad monitors,—the "Sanspareil," the "Perseverance," and the "Rocket,"—the latter, Stephenson's engine with its steam-blast and multi-tubular boiler. The "Rocket" fulfilled all the conditions, and obtained the prize; her driver that day was Charles Fox, the future builder of the Crystal Palace.

The public opening of the road took place September 15, 1825. There was a gay cortege of eight trains drawn by as many locomotives—the latter decorated with flags. The people were *en fête*, and lined the road by thousands; "ale almost flowed in the streets"; "all the musical instruments for hundreds of miles around were got together, and were scraped, blown, beaten, and twanged at once, to an accompaniment of church bells and booming cannon." For the nobility and the Duke of Wellington there was a large and elegant car, and for the Directors and the musicians other cars only less fine. Each train of cars was distinguished by its own color in the matter of flags and streamers. The pleasure of this historical day was not, however, unmixed. Poor Mr. Huskisson, member of Parliament from Liverpool, was run over and killed by the "Rocket," and there was continual apprehension of a violent demonstration against the Duke of Wellington, who was at that time Prime Minister, and had obstinately refused to listen to the cry for Parliamentary reform. Besides, it was a gloomy time, socially; the reaction of the Napoleonic wars was at its height, the laboring classes were suffering, incendiarism was rife, and popular discontent was deep and ominous. But the only demon-

stration at the railway celebration consisted in the pelting of the Duke's car, and in various tokens of discontent exhibited along the line of the road. Altogether the day and the spectacle were of surpassing interest, and deserve to be immortalized by pencil and pen for the admiration of posterity.\*

Turning now to France, we find there the same scene enacted as in England,—the same stupidity encountered, and the same enthusiasm manifested over the final success. In 1830 M. Auguste Perdonnet was treated as a madman for delivering at L'Ecole Centrale in Paris a course of lectures on railroads, and maintaining that the introduction of them would bring about changes equal to those introduced by the invention of printing. But the first French railway (the St. Germain) was built seven years later, and even M. Thiers, on returning from a visit to England, admitted that railways presented some advantages for the transportation of passengers, so long as their use was limited to a few short lines centring in a great

\* Mrs. Frances Kemble, who was at the height of her prosperity at the time here spoken of, was invited by Stephenson, shortly before the formal celebration, to take a ride on his locomotive. Of the famous engineer, she says: "He was rather a stern-featured man, with a dark and deeply marked countenance; his speech was strongly inflected with his native Northumbrian accent, but the fascination of that story told by himself, while his tame dragon flew panting along his iron pathway with us, passed the first reading of the 'Arabian Nights,' the incidents of which it almost seemed to recall. He was wonderfully condescending and kind, in answering all the questions of my eager ignorance, and I listened to him with eyes brimful of warm tears of sympathy and enthusiasm, as he told me of all his alternations of hope and fear, of his many trials and disappointments, related with fine scorn how the 'Parliament men' had badge:ed and baffled him with their book knowledge, and how, when at last they had smothered the irrepressible prophecy of his genius in the quaking depths of Chat Moss, he had exclaimed, 'Did ye ever see a boat float on the water? I will make my road float upon Chat Moss!'" Mrs. Kemble says she was much pleased with "the snorting little engine." Stephenson explained many things to her, assured her that he would make a fine engineer of her, and the result of the whole was that she "fell horribly in love with him."

city like Paris; but the public did not need great trunk lines. When he was asked for a charter for a railroad to Rouen from Paris, he refused, saying that they would throw him out of the tribune if he did so. "Iron is too dear in France," said M. Passy, minister of finance. "The surface of the country is too broken," said the deputy, M. Allier. "The tunnels would be injurious to the health of passengers," said M. Arago.

The Paris and St. Germain railway (eleven miles long) was opened in 1837. Intense was the excitement of the volatile Frenchmen. "*Triomphe merveilleuse!*" "*Plaisir inconnu!*" "*Émotion sans égal!*"—such were the expressions in everybody's mouth. On the opening day the train (says the London "Times" of that year) "started at twelve, to the instant, and then was the clatter of voices raised tenfold. '*Il part—ce coursier de feu et de fumée!* He snorts! he snorts! His prodigious tail of vapor floats in the firmament! *La voilà!*' Even when the engine had attained its extreme velocity, the rattling of tongues was continued, one person shouting into a second's ear, and a third shrieking at the extreme pitch of his voice. '*Cheval magnifique!* Noble and intrepid horse which nothing can stop! He devours the way before him—he snorts! He is clothed with thunder, like the horse of Job! *Corbleu!* what a delicious motion—*n'est-ce pas? Oui, c'est le plus grand plaisir du monde!*'"

But the English are less sanguine than the Latins. We find, in private journals written at the time, a few records that reveal a most reprobate state of mind in the case of certain old gentlemen. Here are the notes of one who travelled over the first two English lines: — \*

\* From "Notes and Queries," August 1, 1868.

“Monday, October 11, 1830, Darlington.—Walked to the railroad which comes within half a mile of the town. Saw a steam-engine drawing about twenty-five wagons, each containing about two tons and a half of coals. A single horse draws four such wagons. I went to Stockton at four o'clock by coach on the railroad; one horse draws about twenty-four passengers. I did not like it at all, for the road is very ugly in appearance, and being only one line, with occasional turns for passing, we were sometimes obliged to wait, and at other times to be drawn back, so that we were full two hours going eleven miles, and they are often more than three hours. There is no other conveyance, as the cheapness has driven the stage-coaches off the road. I only paid one shilling for eleven miles. The motion was very unpleasant—a continual jolting and disagreeable noise.”

On October 27, 1830, the same gentleman made a railroad-journey from Manchester to Liverpool, and has left the following remarks upon it:

“We were two hours and a half going to Liverpool (about thirty-two miles), and I must think the advantages have been a good deal overrated, for, prejudice apart, I think most people will allow that expedition is the only real advantage gained; the road itself is ugly, though curious and wonderful as a work of art. Near Liverpool it is cut very deeply through rock; and there is a long tunnel, which leads into a yard where omnibuses wait to convey passengers to the inns. The tunnel is too low for the engines at present in use, and the carriages are drawn through it by donkeys. The engines are calculated to draw fifty tons. \* \* \* I cannot say that I at all liked it; the speed was too great to be pleasant, and

makes you rather giddy, and certainly it is not smoother and easier than a good turnpike-road. When the carriages stop or go on, a very violent jolting takes place, from the ends of the carriages jostling together. I have heard many say they prefer a horse-coach, but the majority are in favor of the railroad, and they will no doubt knock up the coaches."

A good companion-piece to the foregoing is the following from the journal of Samuel Breck, an old Bostonian (United States):\*

"July 22, 1835.—This morning at nine o'clock I took passage in a railroad car (from Boston) for Providence. Five or six other cars were attached to the locomotive, and uglier boxes I do not wish to travel in. They were made to stow away some thirty human beings, who sit cheek by jowl as best they can. Two poor fellows, who were not much in the habit of making their toilet, squeezed me into a corner, while the hot sun drew from their garments a villanous compound of smells, made up of salt-fish, tar, and molasses. By-and-by, just twelve—only twelve—bouncing factory girls were introduced, who were going on a party of pleasure to Newport. 'Make room for the ladies!' bawled out the superintendent. 'Come, gentlemen, jump up on the top; plenty of room there.' 'I'm afraid of the bridge knocking my brains out,' said a passenger. Some made one excuse, and some another. For my part, I flatly told him that since I had belonged to the corps of Silver Grays I had lost my gallantry, and did not intend to move. The whole twelve were, however, introduced, and soon made themselves at home, sucking

\*Quoted by Charles F. Adams, Jr., in his valuable work on "Railroads: Their Origin and Problems."

lemons, and eating green apples. \* \* \* The rich and the poor, the educated and the ignorant, the polite and the vulgar, all herd together in this modern improvement in travelling. \* \* \* And all this for the sake of doing very uncomfortably in two days what would be done delightfully in eight or ten."

The sentiments expressed in the foregoing citations were decidedly exceptional, if we can judge from the records. As has been intimated, the financial success of railways was so immediate and the novelty of the thing was so fascinating, that speculation ran riot in railroad stock, and, in short, produced the astounding "Railway Manias" that are now a part of history. A fascinating volume could be made on this subject alone. The best accounts that the writer of these lines has met with, are contained in "Frazer's Magazine" for 1844 and 1845, in Francis' "History of Railways," and in the "Banker's Magazine."

The first railway mania was in 1836. The whole country was wild over the construction of new lines. Roads were projected between the most insignificant places. Company after company came into existence,—many of them bogus ones,—and swindlers and adventurers obtained fabulous amounts of gold from the coffers of credulous investors. In Durham, one projector began three railroads all running in parallel lines. Other schemes were equally ridiculous. One man proposed to propel his engines by sails, and induced a company to try them; another was confident that he could propel a locomotive with rockets at a speed of one hundred miles an hour. Another still invented a wooden track to be raised on stilts so as to allow the passage of traffic below.



"But soon a panic came over the town,  
     Heigho! says Reilly,  
 Soon a panic came over the town,  
 And the small men were done most excessively brown,  
     Wily, silly, gammon and bubble!  
     Heigho! says Mither Reilly."

The bubble burst, and England was filled with distress. Great firms failed by the score. One hundred thousand laborers in Manchester, Glasgow, and Paisley were thrown out of employment for months, and the receipts of the custom house sank nearly one million pounds in a single quarter.

The delusion and madness of the great mania of 1844 and 1845 were even more widely extended. The railway investments made in the years from 1830 to 1844 had had the effect of establishing such lines as were most urgently needed; and yet the stock of even these lines had not been rated at a premium until 1843. In the spring of 1844 the mania began. Two hundred and fifty-two new roads were projected. In 1845 the stock of *six hundred* projected railroad lines was in the market, the capital required for all of which amounted to *two thousand millions of dollars!* In 1845 no less than thirty-two railway journals were started, and of them all only four were in existence at the close of 1846! "Every nook and corner of England which with any show of decency could be described in public print as 'an important district, abounding in traffic,' etc., was forthwith occupied by an incipient railway company." In Scotland and Ireland the fever was almost as bad. In the rural districts railway steam-engines on the atmospheric plan were not only to operate the railway lines, but employ their surplus power in impregnating the earth with carbonic acid and other gases, so that veg-

etation might be forced forward in spite of the ordinary vicissitudes of weather, and corn grow at railway speed. "Even the caution of aged spinsters is giving way," says a contemporary writer; "they no longer look upon the railway schemes as a mockery and a snare; but, fired by the occasional paragraphs of the penny-a-liners in the papers, that Mr. *So-and-so* has made so many ten thousands by one investment, and so many hundred thousands by another, they begin to think they ought to seek a participation in this easily acquired wealth, and talk to their brokers of selling out of *consols* and purchasing of '*scrip*.'" The extent to which the craze had infected the women is well shown also in a vivacious article published in a contemporary journal ("Bentley's Miscellany" for 1845):

"Have you got any Spitzbergen and Patagonia?"

"I am sorry to say that I have."

"Why so? they are at two premium."

"But I bought at three and a half."

"Don't be afraid; hold on."

"Hold on! I can't help myself. There is actually no business doing in them."

"The surest sign that they are to have a sudden and tremendous rise."

"When?"

"At the proper time. Hold on!"

"This hint was given to me by a woman — one of consideration,—with a look and tone that would indicate a knowledge of things behind the curtain. I hope that she knows a move or two in the chequered game; if not, as far as I am concerned, it will not be of much consequence. I shall pay for my lesson, and that's all. Small men ought to stick to their trade of basket making. And I shall

profit by my lesson, you may depend upon it. '*Une fois philosophe; deux fois joueur déterminé.*'

"Perhaps the men think they have the game all to themselves; that they alone are railroad mad. If they do, they are grievously mistaken. What is it that makes London by far less dull just now than it usually is during the autumn? Numbers of the *beau sexe* have remained behind to look after the main point, for emphatically is railroad speculation considered the main point amongst, I am sorry to say, too many of them at this moment. Paris, for the same reason, has been scarcely more gay at any season of the year than the present. A certain fashionable and fascinating marchioness (an Englishwoman, too), a resident of the gay capital of delights, won twenty-five thousand pounds there a few weeks back in one *belle swoop*. You would like to know how she did it. A brilliant company were assembled at the hotel of a Russian nobleman in the Faubourg St. Honoré; and between the pauses of the *danse*, a distinguished singer of the opera was entertaining the guests with a favorite air from 'Norma,'—it might be from 'Il Barbieri,' or 'Don Giovanni,' or it might not. All was breathless attention, and intense delight. No! not all. The young Marchioness of — occupied a *fauteuil* in a corner of the *salon*. The air was beautiful —

"She heard it, but she heeded not—her eyes  
Were with her heart, and that was far away,'

very far away—in the share-market! for even into such a gentle bosom, and amidst such a scene, the ruling passion of the age,—call it avarice, gambling, what you will, — could enter and assert its empire.

"I have got a better song for your ladyship than even

Mario's song,' said a young and gallant cavalier, approaching her softly, and seating himself on an unoccupied couch beside her.

“‘What is it?’ said the Marchioness hastily.

“‘Within the last hour the King has expressed to the minister his approval of the Great Northern line. Hush! don't speak or appear agitated; we may be observed.’

“‘Was R—— there?’

“‘Yes! — closeted for two hours with you know whom; and he left the palace about a minute or two before me with a joy in his face that I shall never forget. It spoke millions. You must see him to-morrow early; for the news will be over the town before evening, and the applications will be innumerable.’

“‘To-morrow! — to-night!’ And in a few moments, her Ladyship's carriage having been ordered, she left for the house of the great financier.

“It was in vain that porter and portress, valet and butler, major-domo and secretary, opposed the entrée of the fair besieger. Stop a woman, indeed, when she *will* go ahead! — stop a house on fire with a single bucket of water! She made her way to the sanctum sanctorum — the bureau of bureaux. It was not her first time. Plutus was not petrified; he knew the goddess well. He knew, too, that she must be obeyed; so, to save time, every moment of which was worth a diamond to him that night, he obeyed the commands of his fair tyrant. She arranged for a pretty considerable transaction, and departed to sleep happily on her pillow.

“From the titled dame to the actress, even to the grisette, all the women are playing the railroad game in Paris. In London, if things are not going on *pari passu*, at the

same mail-train pace, amongst the female speculators, they are going on fast enough, Heaven knows!" \*

An indication of the rapidity with which the delusion had pervaded all classes in England is afforded by the number of witnesses who were brought up to London to testify to the desirability of such and such a railroad, through this or that region. There were thousands of these witnesses in town, and the service of the best hotels, with a guinea a day, naturally inclined them to rose-colored views of the particular project they were asked to favor.

It was delicious to listen to the debate of two crack engineers pitted against each other in the service of rival lines. If a mountain stood in the way of your sanguine engineer, he would plunge fearlessly through it, discover in its bowels minerals of surpassing value, and come out safe and sound on the opposite side, "as though he had been perforating a gigantic cheese instead of hammering his path through whinstone coeval with creation." If a lake stood in his way he would be sworn that to drain it would be of immease advantage to the abutters, and he was "indignant at the supposition that any human being could be besotted enough to prefer the prospect of a budding garden to a clean double pair of rails beneath his bedroom window, with a jolly train steaming it along at the rate of some fifty miles an hour."

Of course among so many speculators and manipulators, some became enormously rich. The great hero of the day was George Hudson, of York, the prototype of modern "Railway Kings." During his brief reign he was a universal favorite; a man of tremendous energy, contagious

\* Thackeray gives another ludicrous picture of railway speculation in the "Diary of C. Jeames de la Pluche, Esq."

enthusiasm and convincing eloquence. When he undertook to push a railroad, it was understood that it would be successful;\* the choicest aristocracy of England sought his presence; it was reported with delight that his empire extended over one thousand miles of railroad; his suddenly acquired wealth was enormous (he made five hundred thousand dollars in one day), and his benefactions generously large. A fine arithmetician, he would lean his head back on his chair, cover his eyes with his hands, and arrange expenses and calculate dividends and interest with marvellous accuracy. He had a heavy frame, a piercing gray eye, gray and scanty hair, a broad and wrinkled face, harsh and severe in expression, but lighted up at times by a winning smile. When the crash came, in the tag-end of 1845, Hudson's brief summer sun of glory set in clouds; he was called "a stain upon the nation," his accounts were said to show crooked transactions involving thousands of pounds. Like so many of his American brethren of a later date, he kept no books and retained no copies of his letters, so that it is really difficult to fix the precise amount of blame to be attached to him. But the general opinion of those who have estimated his character is that he was guilty of moral obliquity and of rash investments of money, although his railroads were laid in well chosen localities, and ultimately proved successful.

\*Listen to Carlyle's sarcasm: "The practical English mind, contemplating its divine Hudson, says with what remainder of reverence is in it: 'Yes, you are something like the Ideal of a Man; \* \* \* You find a dying railway; you say to it, Live, blossom anew with scrip;—and it lives and blossoms into umbrageous scrip, to enrich with golden apples, surpassing those of the Hesperides, the hungry souls of men. Diviner miracle what God ever did? Hudson, though I mumble about my thirty-nine articles, and the service of *other* divinities,—Hudson is my God, and to him I will sacrifice this twenty-pound note; if perhaps he will be propitious to me.'"—LATTER-DAY PAMPHLETS, No. VII.

## CHAPTER III.

### THE FIRST AMERICAN RAILROADS.

AMERICA not only ranks first among the nations in the development and extension of the railroad, but in this country the origin of the institution was entirely independent of that in England. We can match Richard Trevithick with Oliver Evans, of Philadelphia; and Thomas Gray with Colonel John Stevens, of Hoboken. Our first locomotives were entirely home-made, and as quaint and curious as they were unique. In short, the fertile genius of the American seized upon the locomotive from the very start as just the tool needed for the rapid conquest of the Continent, and new-world railway appliances are now confessed to be unsurpassed in ingenuity and efficiency.

In the very year that Trevithick finished his Pen-y-dar-ran locomotive, Oliver Evans traversed the streets of Philadelphia with a steam-wagon, or boat on wheels, which he called the "Oruktor Amphibolis." Evans has been called the Watts of America, on account of his numerous inventions of steam machinery. In 1813 he published a little volume in which he made the following remarkable prophecy:

"The time will come when people will travel in stages moved by steam-engines from one city to another, almost as fast as birds can fly, fifteen or twenty miles an hour.

"Passing through the air with such velocity, changing

the scenes in such rapid succession, will be the most exhilarating exercise.

"A carriage will set out from Washington in the morning, the passengers will breakfast in Baltimore, dine at Philadelphia, and sup at New York the same day.

"To accomplish this, two sets of railways will be laid (so nearly level as not to deviate more than two degrees from a horizontal line), made of wood or iron, on smooth paths of broken stone or gravel, with a rail to guide the carriages, so that they may pass each other in different directions, and travel by night as well as by day; and the passengers will sleep in these stages as comfortably as they now do in steam stage boats.

"Twenty miles per hour is about thirty-two feet per second, and the resistance of the air will then be about one pound to the square foot; but the body of the carriages will be shaped like a swift-swimming fish, to pass easily through the air. \* \* \*

"The United States will be the first nation to make this discovery, and to adopt the system, and her wealth and power will rise to an unparalleled height."

This foreshadowing of the railroad is even more remarkable than that of old Erasmus Darwin, embodied in the well known lines:

"Soon shall thy arm, unconquered steam, afar  
Drag the slow barge, or drive the rapid car."

Darwin's "rapid car" was only a "fiery chariot," as he called it, or steam locomotive for common roads. As to the prophecy of "Mother Shipton,"

"Carriages without horses shall go,  
And accidents fill the world with woe,"

it is sad to have to admit that it is an unblushing forgery.



The real "Mother Shipton," it is now known, is a certain Charles Hindley, of London, who about 1867 forged the prophecies which he published to the world under the fictitious name.

Colonel John Stevens, of Hoboken, shares with Oliver Evans and Thomas Gray the honor of being the first to propose plans for steam railroads for passengers and freight. In 1812, when the only locomotive in the world was that of Trevithick, he wrote to the New York Commissioners for the Improvement of Internal Navigation (the chairman of whom was Gouverneur K. Morris) to this effect: "Let a railway of timber be formed, by the nearest practicable route between Lake Erie and Albany, the angle of elevation in no part to exceed one degree, or such an elevation, whatever it may be, as will admit of wheel carriages, to remain stationary, whenever no power is exerted to propel them forward. This railway throughout its course to be supported on pillars raised from three to five or six feet above the surface of the ground. The carriage wheels of cast iron, the rims flat, with projecting flanges, to fit on the surface of the railways. The moving power to be a steam-engine nearly similar in construction to the one on board the 'Juliana,' a ferryboat plying between this city and Hoboken."

Colonel Stevens said, also, that if the Indian proa could be driven through the water at the rate of twenty miles an hour, he saw no reason why locomotives might not move at the rate of one hundred miles an hour, on smooth rails. But the commissioners objected to the cost, and urged the then unexploded theory that the locomotive would not have grip, or bite, enough to draw a heavy load. Colonel Ste-

vens replied that his road could be tested at an expense of about three thousand dollars. But nothing was done.

As nearly everybody interested in railroads is aware, the first actual iron road in the United States was the old "Granite railroad" of Quincy, Massachusetts. It was constructed in 1826 by Gridley Bryant, and received great financial aid from Thomas Handasyd Perkins, of Boston. The enterprise excited deep interest throughout the country, and the road is referred to as a model in all the early papers and legislative documents relating to the first railroads. Bryant had closely studied the railroads of George Stephenson, but was himself an inventor of new railroad appliances, such as the switch, portable-derrick, and eight-wheeled car; all of which were first used on the Quincy railroad. Bryant's claim to the invention of the eight-wheeled car was unsuccessfully disputed in the courts by Ross Winans, who constructed the first eight-wheeled car used on the Baltimore and Ohio railroad, patenting his invention in 1834. This litigation about the movable truck lasted five years, and cost, it is said, two hundred and fifty thousand dollars. Bryant's car was only the combination of two four-wheeled trucks for the transportation of long pieces of granite designed for columns; the courts, however, decided in his favor, but not before Winans had made immense sums from his patents. Winans died worth, it is said, over twenty millions of dollars, while Bryant, who had not patented his devices, had no legal right to royalty, and never, in fact, received a cent for his invention of the car.

The Quincy railroad was designed and built by those interested in getting material for the Bunker Hill Monument from the five granite quarries of Quincy. The road

had a considerable incline from the quarries toward the landing-place on the Neponset River, and a single horse drew immense loads over the rails. From the wharf the granite blocks were towed around the harbor by a steam tow-boat and landed at Charlestown. The total cost of the railroad was thirty-four thousand dollars; the distance traversed was three miles, and there was a double track constructed of stone ties eight feet apart, upon which were laid longitudinal beams plated on the top with iron. The cars carried their load on a platform under the axle, or



FIRST AMERICAN RAILWAY (THE "GRANITE ROAD").

if the blocks were large, they were slung in chains. The wheels of the cars were of wood, six feet in diameter, and shod with iron one-half of an inch thick, with a flange on the inner side of the rim. When the snow came they invented a railroad snow-plough,— the first ever made; it is thus spoken of by a contemporary writer: "Even the late snow, which is deeper than has before fallen for several years, has presented no obstruction. On first passing, while the snow was light, two pieces of plank were placed before the car, meeting in an angle at the centre, and drawn along the rails, and by this means the snow was

effectually removed, so as to render the travelling of the wheels as free as in summer." In 1871 the old Granite railway ceased to exist, being purchased by the Old Colony railroad, and the original track was replaced by a new one.\*

The next railroad in order of time was the "Gravity" road, of Mauch Chunk, Pennsylvania, finished in May, 1827. It was nine miles in length and was built to carry coal from the Summit mines in Carbon county, Pennsylvania, to a landing on the Lehigh River. The road consisted of a series of inclines, and the motive force was of a double nature—gravity and mule-power. The mules were allowed to ride down the inclines, a peculiar kind of platform being designed for their use. It is said that they learned to enjoy the ride so much that nothing could induce them to walk down the slopes.

In 1828 a Dry Dock railway was in use at Burnt Mill Point, New York city. It was used to hoist ships out of the water for repairs, and consisted of a cradle travelling on small iron wheels over an inclined plane, which projected several hundred feet under water. A stationary steam-engine supplied the power; and horse-power was also used at times.†

The next railroad was that built by the Delaware and Hudson Canal Company to connect their mines at Carbondale with the town of Honesdale—the terminus of the canal. It is a gravity railroad, and its present appearance

\* The fullest descriptions of the Quincy railroad are given in Nathan Hale's "Remarks on the Practicability, etc., of a Railroad from Boston to the Connecticut River," Boston, 1827, and in the chapter on Canals and Railroads in Volume IV of the "Memorial History of Boston." The cut above given originally appeared in C. H. Snow's "Geography of Boston" (Carter and Hendee, 1830).

† See "Picturesque New York," A. T. Goodrich, 1828. The author has never seen this road referred to in any other work on railways.

and machinery will be described in Chapter VIII, "Mountain Railways," where the reader will also find descriptions of the Old Portage railroad over the Alleghanies, and the Old Mountain Top Track road of Virginia. In 1829 the canal company's road had only wooden rails and was operated by mule-and-horse-power. *It was upon this road that the first revolution on American soil of the driving-wheel of a locomotive was made.* The fame of the doings of Stephenson and others in England had reached America in 1825, and in 1828 Mr. John B. Jervis, engineer of the Delaware and Hudson canal, sent over his assistant, Horatio Allen, to England to be present at the Rainhill contest of competing locomotives, and commissioned him to buy three of the best in England. Young Allen tried to get Stephenson's services in the construction of the three locomotives; but Stephenson was too busy to attend to them; so they were finally constructed by Foster Raswick and Company, of Stourbridge. The first one arrived in New York in May, 1829. It was one of the "grasshopper" make, and had a fierce lion's head painted in red on the front of the boiler—hence its name, or sobriquet, the "Stourbridge Lion." It was first exhibited at the West Point Foundry, foot of Beach Street, New York city (the birth-place of so many of the early American locomotives), and then taken to Honesdale. The trial-trip occurred on the 8th of August, 1829. The whole population within a radius of forty miles turned out to see the spectacle, and an old Queen Anne cannon was brought up from New York to add its voice to those of the people. Honesdale is named after Philip Hone, once mayor of New York. In 1829 it was a town of only a few hundred inhabitants, but is now a city of considerable size.

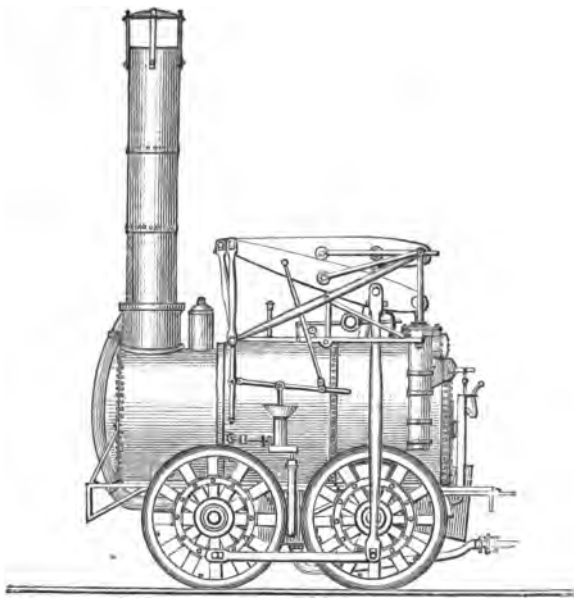

(By courtesy of the "Railway Age.")

THE "STOURBRIDGE LION."

The track of the railroad consisted of hemlock rails spiked to hemlock ties. Having been laid in summer, the unseasoned rails had got a good deal warped and twisted before the opening day. The road crossed the Lackawaxen River over a frail hemlock trestle, one hundred feet in height, and as the locomotive was found to weigh seven tons instead of four, as the contract had stipulated, it was feared by everybody that the trestle would not bear its weight. Mr. Horatio Allen, who had charge of the engine, was implored by many prominent men who were present not to attempt to cross the river. But the garland of glory and fame was floating before the eyes of the young engi-

neer, and after running slowly backward and forward a few times before the assembled multitude, he pulled the throttle-valve open, and, shouting a loud good-bye to the crowd, dashed swiftly away around the dangerous curve, and over the swaying bridge. After running a few miles he returned in safety, amid the shouts of the people and the booming of the cannon.

The locomotive was a success, but the company was not rich enough at that time to purchase iron rails, and the wooden ones proving too frail for the engine, it was housed in a shanty, on the canal dock, where it lay for years a prey to rust and decay. The boiler was afterward used in a foundry at Carbondale; the pump was used for several years by an employé of the company, and finally lost; and the rest of the old hulk was partly hacked to pieces by relic hunters, and partly sold for old iron. Horatio Allen, who figured so conspicuously on this occasion, is a graduate of Columbia College. He built the first eight-wheeled locomotive, and has been successively assistant engineer on the Croton Aqueduct, president of the New York and Erie railroad, president of the American Society of Civil Engineers, and consulting engineer of the great New York and Brooklyn bridge.

The curtain next rises upon an unusually attractive scene in which the figure of the noble philanthropist and manufacturer, Peter Cooper, is the centre of interest. It curiously marks the recent origin of the railroad system that the man (Peter Cooper), who built the first railroad locomotive ever made in America, was alive in 1882, and yet was forty years old when he constructed his locomotive. Mr. Cooper not only built the first American locomotive, but what was more important, he proved that it could run

at a high rate of speed round curves of a short radius. In consideration of these services he has been called "The Father of the Locomotive System in America."

In 1826 Baltimore woke up to the fact that she must do something to regain the trade that the Erie canal and the roads of Pennsylvania were taking out of her hands. It was decided to build a railroad through the Potomac Valley and over the Alleghanies. The first section of the road was opened in 1830. It consisted of a double track extending thirteen miles to Ellicott's Mills. "What motive-power shall we have?" that was the great question. The horse-car experiment did not pay, and various other devices were tried. Evan Thomas built for the road a car with sails, which ran when the wind was favorable. Baron Krudener, Russian envoy to this country, rode on this car, and managed the sail himself, declaring that he was charmed with his ride. But the thing was of little value. Then they tried a horse-power car, a machine somewhat like the wood-cutting apparatus we see at railway stations, only the horse on the Baltimore road propelled himself and his fellow passengers over the rails instead of sawing wood with a buzz-saw. The horse-power car worked pretty well, but on one occasion, when drawing a number of editors and other representatives of the press, the machine ran into a cow, and ignominiously upset the inspecting company in a ditch. And, inasmuch as the company had to endure thereafter innumerable bad jokes and puns (for example, "the *cowed* editors"), they naturally passed an unfavorable verdict upon the machine which had subjected them to this annoyance.

How it next came to pass that Peter Cooper built his little engine, the "Tom Thumb," and made his famous



trial-trip on the railroad, he must be allowed to tell in his own graphic way:\*

“It is now about fifty-five years since I was drawn into a speculation in Baltimore. Two men there, whom I knew slightly, came up and asked me to join them in buying a tract of three thousand acres of land within the city limits. It included the shore for three miles, and the new Baltimore and Ohio railroad was going to run through it. The

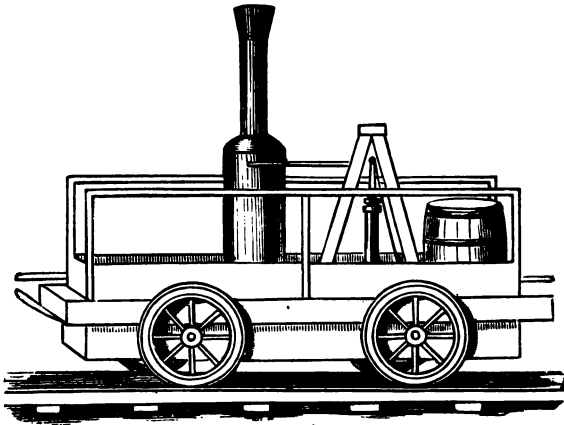

(By courtesy of the "Railway Age.")

PETER COOPER'S LOCOMOTIVE.

road was chartered, and a little of it was graded. Its cars were to be drawn by horses; nobody thought of the possibility of steam. I consulted my friend Gideon Lee, who served as alderman with me fifty-two years ago now, and he advised me that it was a good scheme. He said the land was worth five hundred thousand dollars, whether the road was ever finished or not. So I went to Baltimore, saw the land, and agreed to take one-third, and paid my money, twenty thousand dollars.

\* As reported in the Boston "Sunday Herald" for July 9, 1882.

“They drew on me every little while for taxes, etc., and when, at the end of a year, I went down again, I found out that neither of my partners had paid a cent on the purchase, and that I had been sending down money to pay their board! The Baltimore and Ohio railroad had got some wooden rails laid, and thinking it might amount to something, I bought my swindling partners out, paying one of them ten thousand dollars. I thought it would pay, for the Baltimore and Ohio railroad had run its tracks down to Ellicott's Mills, thirteen miles, and had laid ‘quakehead’ rails, as they called them, strap rails, you know, and had put on horses. Then they began to talk about the English experiments with locomotives. But there was a short turn of one hundred and fifty feet radius around Point of Rocks, and the news came from England that Stephenson said that no locomotive could draw a train on any curve shorter than a nine hundred foot radius. The horse-car didn't pay and the road stopped. The directors had a bad fit of the blues. I had naturally a knack at contriving, and I told the directors that I believed I could knock together a locomotive that would get the train around Point of Rocks. I found that my speculation was a loss unless I could make the road a ‘go.’

“So I came back to New York and got a little bit of an engine, about one horse-power (it had a three and a half inch cylinder, and fourteen inch stroke), and carried it back to Baltimore. I got some boiler iron and made a boiler, about as big as an ordinary wash-boiler, and then how to connect the boiler with the engine I didn't know.”

“You had been a worker in wood, I believe,” said the gentleman to whom this narrative was imparted by Mr. Cooper.

“ Yes, and in iron, too. I had not only learned coach-making and wood carving, but I had an iron-foundry and had some manual skill in working in it. But I couldn't find any iron pipes. The fact is that there were none for sale in this country. So I took two muskets and broke off the wood part, and used the barrels for tubing to the boiler, laying one on one side and the other on the other. I went into a coach-maker's shop and made this locomotive, which I called the 'Tom Thumb,' because it was so insignificant. I didn't intend it for actual service, but only to show the directors what could be done. I meant to show two things: first, that short turns could be made; and, secondly, that I could get rotary motion without the use of a crank. I effected both of these things very nicely. I changed the movement from a reciprocating to a rotary motion. I got steam up one Saturday night; the president of the road and two or three gentlemen were standing by, and we got on the truck and went out two or three miles. All were very much delighted, for it opened new possibilities for the road. I put the locomotive up for the night in a shed. All were invited to a ride Monday — a ride to Ellicott's Mills. Monday morning, what was my grief and chagrin to find that some scamp had been there, and chopped off all the copper from the engine and carried it away — doubtless to sell to some junk dealer. The copper pipes that conveyed the steam to the piston were gone. It took me a week or more to repair it. Then (on Monday it was) we started — six on the engine and thirty-six on the car. It was a great occasion, but it didn't seem so important then as it does now. We went up an average grade of eighteen feet to the mile, and made the passage (thirteen miles) to Ellicott's Mills in an hour and twelve minutes.

We came back in fifty-seven minutes. Ross Winans, the president of the road, and the editor of the 'Baltimore Gazette,' made an estimate of the passengers carried and the coal and water used, and reported that we did better than any English road did for four years after that. The result of that experiment was that the bonds of the road were sold at once, and the road was a success."

From other sources\* we are enabled to supplement Mr. Cooper's narrative in a few points. One of the passengers — Mr. H. H. Latrobe — says that the trip to the Mills was most interesting. The curves were passed without difficulty, at a speed of fifteen miles an hour; the grades were ascended with comparative ease; the day was fine, the company in the highest spirits, and some excited gentlemen of the party pulled out memorandum-books, and when at the highest speed, which was eighteen miles an hour, wrote their names and some connected sentences, to prove that even at that great velocity it was possible to do so.

The "Tom Thumb" weighed about a ton; the wheels were two and a half feet in diameter; the fuel, anthracite coal. The smoke-stack "looked like an aggravated putty-blower." The tubes in the upper part of the boiler were an anticipation, or rather an independent and almost simultaneous invention of the multi-tubular arrangement of George Stephenson, which, together with the steam-blast, gained him the victory at Rainhill, a year after the "Alderman Cooper" experiment. It is important to remember the fact of the prior and independent invention in America of two of the fundamental features of all locomotives. Mr. Cooper's steam-blast apparatus consisted of a sort of bel-

\* W. H. Brown's "History of the First Locomotives in America," and the "Baltimore Gazette."

lows, which was operated by a belt running over a drum and geared with the car-wheels. But it was this very steam-blast device which lost the "Tom Thumb" the race with a horse owned by the stage proprietors, Stockton and Stokes, of Baltimore. The little engine had been out a number of times, and although starting off with much puffing and leaking of steam from its joints, had answered all the expectations of its ingenious inventor. But on the day of trial just described, the stage proprietors, having learned that the engine was on the track, "brought down a gallant gray of great beauty and power, and attached him to a car on the second track, and met the returning engine at the Relay House—so called because relays of horses were generally procured there. From this point they determined to have a race back, and away went horse and engine—the snort of the one keeping time to the puff of the other. The gray had the best of it at first, getting a quarter of a mile ahead while the engine was getting up its steam. The blower whistled, the steam blew off in vapory clouds, the pace increased, the passengers shouted, the engine gained on the horse, lapped him, the silk was applied, the race was neck-and-neck, nose-to-nose; then the engine passed the horse, and a great hurrah hailed the victory. But just at this moment, when the gray's master was about giving up, the band which turned the pulley that moved the blower slipped from the drum, the safety valve ceased to scream, and the engine, for want of breath, began to wheeze and pant. In vain Mr. Cooper, who was his own engineer and fireman, lacerated his hands in attempting to replace the band on the wheel; the horse gained on the machine, and passed it, to his great chagrin; and, although the band was presently replaced, and steam

again did its best, the horse was too far ahead to be overtaken, and came in winner of the race."

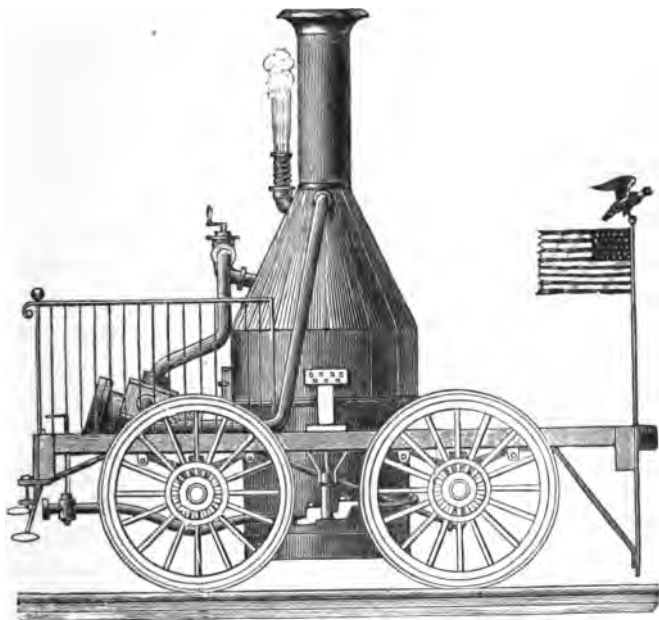

THE "BEST FRIEND."

The first regular passenger railroad in America worked by steam-locomotives was the Charleston and Hamburg, of South Carolina, chartered in the year 1827. The road was eventually one hundred and thirty-six miles long, extending from Charleston to Hamburg on the Savannah River, but only six miles were completed during the first year. The first American-built locomotive for actual service on a railroad was the "Best Friend," built for this South Carolina road in the West Point Foundry, and first

operated on the track in November or December, 1830. The horse-power and sailing car\* experiments had been tried by the directors of this southern road, too, but had not proved of practical value. A premium of \$500 had been offered by the directors for the best horse-power car, and it had been taken by Mr. C. E. Detmold, for a machine in which the horse worked on an endless-chain platform. His machine was called "The Flying Dutchman." But the new steam-engine captivated everybody, and it was resolved to use no other motor on the new railroad. This was a courageous step to take at that early date, and South Carolina people can now boast that the directors of the first passenger railroad in that state, and in the United States, were the earliest railroad officials in the world to disown all motors except steam. The "Best Friend" had a vertical boiler devoid of fire-tubes and looking very much like a gigantic beer-bottle. The furnace at the bottom of the boiler was surrounded with water, and protuberances called teats ran out from its sides and top in order to secure more heating surface. The machine ran for about a year and then exploded its boiler, owing to the unsuccessful attempt of the negro fireman to stop the annoying hissing of the steam by sitting on the safety-valve. The negro had his thigh broken, and afterward died from the effects of the accident. The engineer, Nicholas W. Darrell, was at the same time pretty badly scalded. On January 15, 1831, the managers of the road, having obtained another engine, the "West Point," celebrated the anniversary of the opening of the road. The day was raw and chilly, but the few hundred guests and stockholders that assembled are reported to have had a pleasant and even

\* For an account of the sailing car experiment, see Chapter VII.

“hilarious” time. A negro band discoursed sweet music, and, to allay the fears of the nervous, a car loaded with cotton bales was placed between the locomotive and the passengers.

Suppose now a year to have passed, and let the scene be shifted from the land of the palmetto to the land of the pine, or from Charleston to Albany, New York. It is ten o'clock in the morning of August 9, 1831. At the head of Lydius street, two miles from the Hudson River, which creeps silverly away southward between green hills, there stands on a railroad track a queer-looking locomotive, and behind it are a tender and two strange passenger cars, consisting of the bodies of stage-coaches fastened upon railroad trucks. A great crowd is assembled, and it is nearly time to start the train. The railroad is the Mohawk and Hudson; the company has been running its cars by horse-power, but has recently received by river-boat from the West Point Foundry a new motor in the shape of the locomotive engine, “De Witt Clinton,”—the third one built in the United States for actual service, and the first of that character ever run on a passenger railroad in the northern states. Accordingly, everybody is full of interest and curiosity, and at all available points along the sixteen miles of railroad between Albany and Schenectady, the farmers are out in force, with their teams and families, to see the wonderful iron steed. It happens that a travelling silhouette-artist, named William H. Brown (afterward author of the work on the “First Locomotives in America”), is in Albany on this gala-day, and, finding everybody going to see the locomotive, concludes to go likewise; for artist Brown is in the habit of snipping out of black paper not only very good individual portraits, but also



representations of whole groups of people, as well as race-courses, harbors, buildings, etc. Arrived in presence of the curious train of cars, he sees his opportunity for securing a nice advertising plum; so he whips out a letter from his pocket, inverts his hat for a desk, and hastily makes a rough drawing of locomotive and tender, and the first two passenger-coaches. In the evening of the same day he neatly cut out of a sheet, or sheets, of black paper, six feet in length, his now famous profile-picture,—modelled upon the sketch,—and, after exhibiting it in Albany, presented it to the Connecticut Historical Society, where it is still cherished as one of the society's choicest treasures. It has often been reproduced in print.\*

But conductor John T. Clark, having stepped from platform to platform outside the coaches to collect the tickets (previously sold at hotels and other public places throughout the city), now mounts a little buggy-seat at the top of the tender, and blows a tin horn as the signal for departure: the engine starts with a great jerk; and to the accompaniment of much puffing and wheezing from it, and loud shouts from the crowd, the train moves off amid a cloud of smoke and a shower of sparks, and goes "thundering along" toward Schenectady. Among the passengers are profile-artist Brown and Judge J. L. Gillis. The latter gentleman has left as graphic a picture of the trip as the artist has of the cars and engine. Says Judge Gillis:

\*The faces of those in the coaches are actual likenesses, as is the case also with the engineer. The names of the engineer and passengers are as follows, beginning at the locomotive: David Matthew, engineer; FIRST CAR, Erastus Corning, Mr. Lansing, ex-Governor Yates, J. J. Boyd, *Thurlow Weed*, John Miller, Mr. Van Zant, Billy Winne (penny postman); SECOND CAR, John Townsend, Major Meigs, "Old Hays" (high constable of New York), Mr. Dudley, Joseph Alexander (of the Commercial Bank), Lewis Benedict, and J. J. De-graft.

THE "DE WITT CLINTON" AND COACHES.

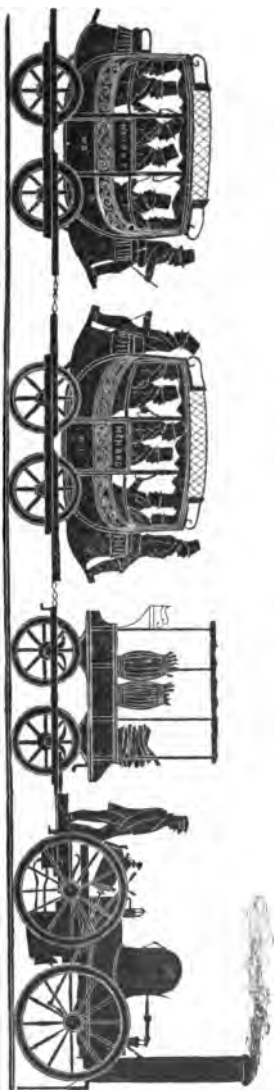

“The train was composed of coach-bodies, mostly from Thorp and Sprague’s stage-coaches, placed upon trucks. The trucks were coupled together with chains, or chain-links, leaving from two to three feet slack, and when the locomotive started it took up the slack by jerks, with sufficient force to jerk the passengers, who sat on seats across the top of the coaches, out from under their hats; and in stopping they came together with such force as to send them flying from their seats.

“They used dry pitch-pine for fuel, and there being no smoke or spark catcher to the chimney, or smoke-stack, a volume of black smoke, strongly impregnated with sparks,\* coals, and cinders, came pouring back the whole length of the train. Each of the outside passengers who had an umbrella raised it as a protection against the smoke and fire. They were found to be but a momentary protection, for I think in the first mile the last one went overboard, all having their covers burnt off from the frames, when a general *mêlée* took place among the deck-passengers, each whipping his neighbor to put out the fire. They presented a very motley appearance on arriving at the first station.” At this point a successful experiment was tried for the purpose of remedying the terrible bumps and jerks that were endangering the beaver hats of the dignitaries, and creating such a panic among the second-story passengers. The three links in each coupling having been stretched to their extreme tension, a rail from the next fence was extended horizontally between each pair of cars, and fastened to its place by means of the packing-

\*The author is told, by those who rode on the first American trains, that the sparks from wood-burning locomotives, previous to the invention of the spark-arrester, were often as large as the thumb-nail, and even larger.

yarn used for the cylinders.\* This proved satisfactory, and after a run to Schenectady, where refreshments were partaken of, the train returned to Albany.

“The incidents off the train,” continues Judge Gillis, “were quite as striking as those on board. A general notice of the contemplated trip having been given, it excited not only the curiosity of those living along the line of the road, but of persons at a distance, causing a large collection of people at all the intersecting roads along the route. Everybody, together with his wife and all his children, came in all kinds of conveyances, and, being as ignorant of what was coming as were their horses, drove up to the railroad as near as they could get, only looking for the best position to secure a view of the train. As it approached, the horses took fright and wheeled, upsetting buggies, carriages, and wagons, and leaving for parts unknown to the passengers, if not to their owners, and it is not now positively known if some of them have yet stopped.” Such was the first locomotive-trip in New York.

Albany in 1831 was the centre of a large amount of stage travel, and more capital was embarked in it than in any other enterprise of the time. “Lines of stages diverged to every point of the compass; and the streets of Albany were thronged with vehicles arriving and departing, sometimes in long processions, at every hour of the day and night.”† We are told that on the completion of the railroad just described, many hundreds of worn-out stage-horses were turned out to die. It would seem, therefore,

\*Mr. Charles F. Adams, Jr., has noted the fact that this was the first rude and spontaneous device in the direction of the modern buffer.

† See the “Historical Magazine,” 1871, page 14.

that in America as in England, it was high time for the railroad, and that here as there it supplied an urgently felt want.

It should be added that the old Mohawk and Hudson railroad now forms the eastern terminal portion of the New York Central road. In 1831 there were not—according to Thurlow Weed—above half a dozen houses in the pine-forest which immediately bordered the railroad between Albany and Schenectady. There was an incline at each of these cities, down which the locomotives were unable to pass; but a stationary engine, operating a strong rope and winding-drum, drew the trains up and down the hills.

In November, 1832, the first passenger train in the state of Pennsylvania made its trial trip, being drawn by "Old Ironsides,"—a locomotive built by Mr. M. W. Baldwin, founder of the great locomotive works in Philadelphia, that now bear his name. The accompanying illustration shows the quaint appearance of both cars and locomotive. The latter had wooden spokes, and wrought iron tires. Sometimes the eccentrics would stick fast so that the engine could move in neither direction. Whenever repairs were necessary, they were made in the night, as "Ironsides" was the only locomotive on the road (the Philadelphia, Germantown, and Norristown, opened for travel in the spring of 1832). The locomotive weighed only seven tons, but was thought by the directors to be so heavy that they came near rejecting it, in which case it is probable that its builder would never have constructed another. On the occasion of the trial trip of the "Ironsides" it was discovered that the wheels were too light to keep the machine on the track; so the builder and two machinists pushed it ahead until considerable speed had been obtained, when all jumped aboard

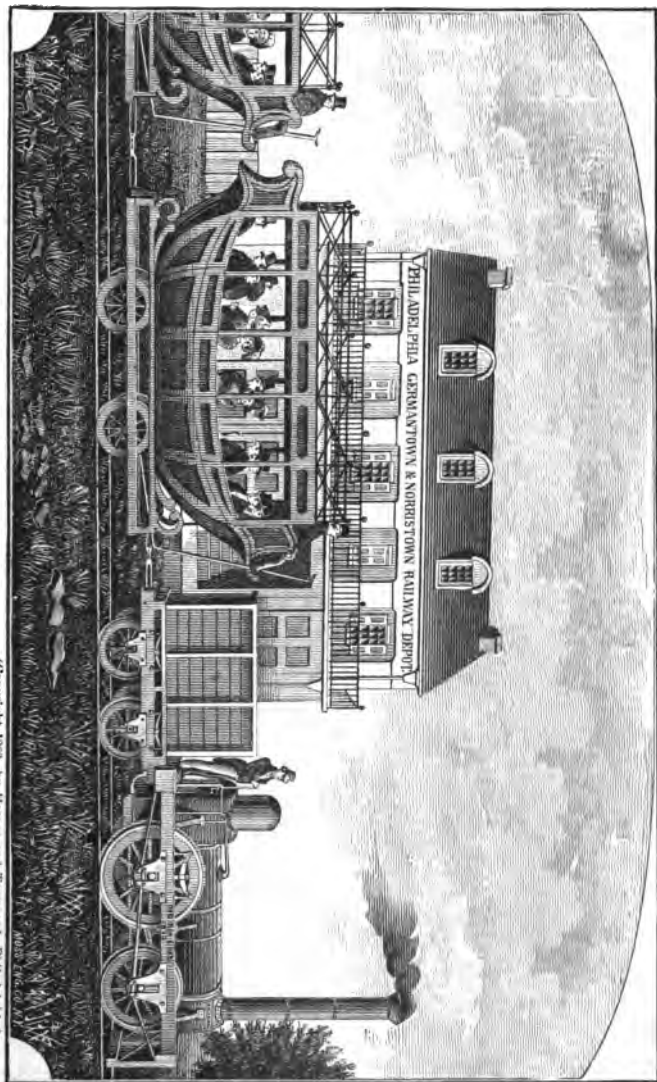

FIRST RAILROAD TRAIN IN PENNSYLVANIA.

(Copyright 1884, by Hoopes and Townsend, Philadelphia.)

in order by their weight to keep the wheels down. Moreover, the boiler was too small for the engine, and steam could only be generated fast enough to keep it in motion for a short time, so that for a large portion of the distance from Philadelphia to Germantown it was necessary alternately to push and ride in order to cover the distance. On the return the connecting pipe between the tank and the boiler became frozen and had to be thawed out with a fire made of rails!

One of the most curious of the early cars was the "Victory" figured on page 55, a model of which is now preserved in the office of the Eastern Railroad Association in New York. It was the first Monitor or raised roof car, and was run on the Philadelphia and Reading railroad in 1836. The seats inside were arranged like those of an omnibus—around the sides. The car was entered from the side, and at each end was a room,—one of these used as a toilet closet, and the other evidently intended for a bar. It seems that our ancestors, in those days of universal drinking, were unable to do without their potations even when on a railway journey.

In the early days of the railroad in this country, freight cars were called "burthen cars," and trains were called "brigades" of cars. The freight cars were boxes a little longer than their width, and had a wheel at each corner. Many of the locomotives had enormous driving-wheels, twelve feet in diameter. On one road, and perhaps on others, a novel head-light was formed by placing a lot of pitch-pine on a platform car thickly covered, as to its floor, with sand. The car preceded the engine, and the burning pine-knots made a famous track-illuminator. Almost all the first railroads made use of wooden rails upon which strap iron was spiked. These strap rails had an unpleasant

THE "VICTORY."

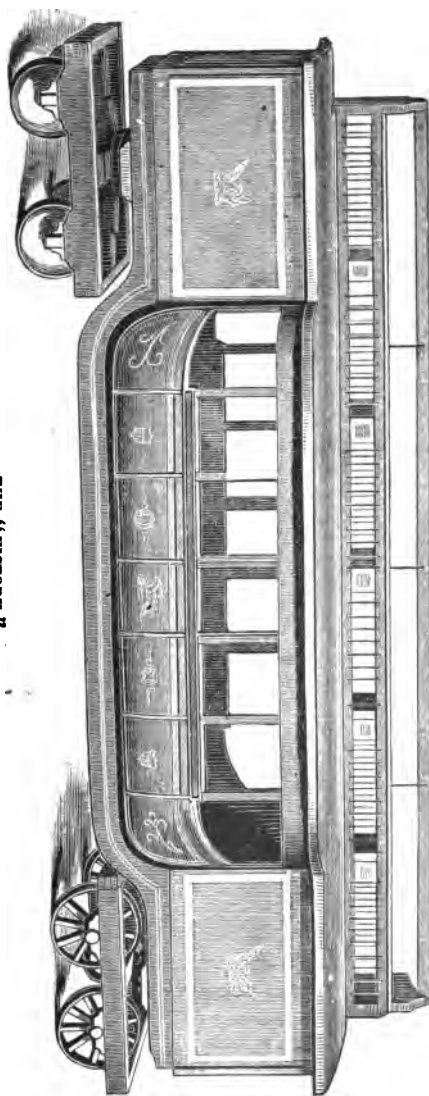



fashion of curling up, owing to the weight of the cars on their central parts, combined with the action of heat and frost. When, then, the ends of the rails were struck by a car-wheel they would often be forced up through the bottom of the car, and the engineer would sometimes be obliged to stop the train and pound down the "snake-head," as it was called, or else detail an assistant to hold it down with a lever while the train passed on. Old engineers say that often the "slab" rails would peel up around the driving-wheel of the engine and whiz past their chins in very uncomfortable proximity. Persons in the cars were often seriously injured by these accidents.

The old stage-travel custom of "booking" passengers was at first transferred to the railroad. And the English ticket-agent still *books* a person for a first, second, or third-class *coach*. In this country the word *car* early supplanted *coach*, doubtless owing to the circumstance that we retained the English form of railway vehicle for so short a time. But the old custom of entering the names of passengers in a book at the railway station was in use, in Pennsylvania at least, as late as 1840. The old booking ledger used at Phoenixville, Pennsylvania, on the Reading railroad, is still preserved. The first entry was made July 17, 1838. But in a year or two there is a manifest falling-off in the care with which names are entered. Instead of the Christian name and surname, some single descriptive word is used,—as "Boy," "Lady," "Stranger," "Friend," "Whiskers." In 1841, by the way, the total monthly receipts of this railroad were seven hundred and forty-five dollars and ten cents.

Massachusetts was slower than her sister states in the adoption of the railroad. The first of her citizens publicly to agitate the subject was Benjamin Dearborn, of Boston,

who in 1819 memorialized Congress in regard to a scheme of his, based upon the plans of Oliver Evans, for introducing railroads into general use.\* But the Father of the Railroad System of Massachusetts is Doctor Abner Phelps, who, at a time when the only means of transportation in the state (other than that of wagons and ships) were the boats of the Middlesex canal, connecting Boston with the Merrimack River, and when surveys had been made for a canal to connect the city with the Hudson River, publicly and privately urged the adoption of the new railroad system which was just springing into existence in England. Doctor Phelps's railroad was, however, to be worked by horse power, with paths at the sides for the horses to travel, as in the case of canals. In short, his road was to be modelled on the already successfully constructed Granite railroad of Quincy. In calling Doctor Phelps the Father of the Railroad System of Massachusetts, we would not do injustice to the indefatigable labors of Nathan Hale, then editor of the Boston "Advertiser." † His series of careful statistical articles on the "Practicability and Expediency of Establishing a Railway on One or More Routes from

\* A curious idea of Dearborn is set forth in the following paragraph of his respecting his proposed railroad system: "Protection from the attacks of assailants will be insured not only by the celerity of the movement, but by weapons of defence belonging to the carriage and always kept ready in it, to be wielded by the number of passengers constantly travelling in this spacious vehicle, where they would have liberty to stand erect and exercise their arms in their own defence."

† On the occasion of the celebration of the "Silver Birthday" of Warren Street Chapel in Boston, the Reverend Edward Everett Hale said that he had often heard his father, Nathan Hale, foretell the future greatness of the railroad. Mr. Hale further said: "As he illustrated the new invention of Stephenson by the toy railroad which he had built for his own drawing-room, I was old enough to chafe as I saw the incredulous smile of his visitors, and the half-contempt with which they tried to turn him from the subject of his delusion." But not long afterward this very lad (now the famous preacher and author) rode in triumph on the first locomotive that ran over what is now the first five miles of the Boston and Albany railroad.

Boston to the Connecticut River," published in 1827, had a very marked influence upon thinking men, as is pretty conclusively shown by the fact that a Legislative Committee was appointed in that year to examine the subject of railroads, and they made a favorable report (alluded to in Chapter IX of this volume).\* The railroad scheme was, however, bitterly opposed by the promoters and favorers of the canal.

But in spite of opposition the railroad was adopted. Charters were granted first to the Boston and Lowell, and afterward to the Boston and Worcester and the Boston and Providence railroads, and the canal scheme was killed. It is natural to find the same stubborn, prehensile conservatism cropping out in Boston that we have noted in the case of England. Of Doctor Phelps's railroad scheme, Joseph T. Buckingham, then editor of the Boston "Courier," wrote to the following effect:

"Alcibiades, or some other great man of antiquity, it is said, cut off his dog's tail that *quidnuncs* might not become extinct from want of excitement. Some such notion, we doubt not, moved one or two of our natural and experimental philosophers to get up the project of a railroad from Boston to Albany, a project which every one knows, who knows the simplest rule in arithmetic, to be impracticable, but at an expense little less than the market value of the whole territory of Massachusetts; and which, if practicable,

\* Among the curious things in this funny report is one of the reasons given why a railroad was needed: "For many years previous to the present season, the *snow* of our winters in Massachusetts has been gradually diminished. Instead of sleighing for four months in a winter, it is now rare for so many weeks, and in the neighborhood of Boston, during the twelve years previous to the present, it has not upon an average been more than sufficient for two weeks." Hence wet and muddy roads, and the inability of the farmers to draw their produce to the market.

every person of common sense knows would be as useless as a railroad from Boston to the moon."

Similar incredulity was encountered by Gridley Bryant, when he was seeking aid to establish his Granite railroad: "What do we know about railroads?" said the thick-headed legislators. "Who ever heard of such a thing?" "Is it right to take people's land for a project that no one knows anything about?"

In like manner, the inhabitants of Dorchester, as late as the year 1842, resolved in a town meeting, "That our representatives be instructed to use their utmost endeavors to prevent, if possible, so great a calamity to our town as must be the location of any railroad through it, and if that cannot be prevented, to diminish this calamity as far as possible" by locating the road through the marshes and over creeks. At the present time some fifty trains a day pass through the nine or more railroad stations of Dorchester, which owes nearly all its prosperity to the institution opposed in 1842 with such amazing fatuity and narrowness of mind.

The railroads to Lowell, to Providence, and to Worcester were publicly opened in the same year, 1835, but the first locomotive trip was made on the Boston and Worcester in March, 1834, and sections of the road were in use for a year before the formal celebration of the opening of the road to Worcester. At the time the road was completed to Newton there appeared in the Boston "Advertiser" the time table and cut shown on page 60.

At Worcester a bell suspended from a tree gave the signal for the departure of trains. Previous to the railroad, baggage wagons accomplished the journey of forty-four miles between Worcester and Boston in a week, if the

weather was good; the locomotive performed the task in three hours. We are informed that at first the daily average transportation of freight was twelve tons one way, and twenty-four the other, and the only freight house of the

**BOSTON AND WORCESTER RAIL ROAD.**

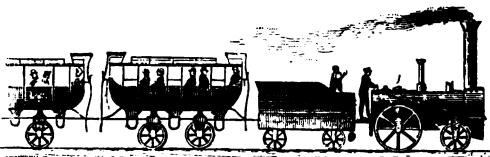

**THE Passenger Cars will continue to run daily from the Depot near Washington Street, to Newton at 6 and 10 O'clock, A.M. and at 3½ O'clock, P.M. and Returning, leave Newton at 7 and a quarter past 11, A.M. and a quarter before 5, P.M.**

Tickets for the Passage either Way may be had at the Ticket Office, No. 617 Washington Street, Price 75 cents each, and for the return Passage, of the Master of the Cars Newton

By Order of the President & Directors  
a 29 Epifts F. A. WILLIAMS, Clerk.

OLD RAILWAY TIME-TABLE.

line (in Boston) could hold but two "burthen cars." Trains ran from Boston to Worcester "three times each day during the warm season, and twice a day during the cold season, excepting Sundays."

The earliest locomotive of the Lowell road was an imported Stephenson machine, which was driven for a time by an imported engineer. The Lowell road made the mistake of laying its fish-belly rails on stone ties, which were in turn placed upon longitudinal walls of masonry sunken in the road-bed, for it was thought that with any less substantial support the locomotive would always be overcoming an ascent caused by the sinking of the road-bed under its weight. The Boston and Provi-

dence road avoided this error, and adopted the elastic wooden bed; the original iron rails of the Providence road were so good that the last of them were not taken up until 1860.

In December, 1841, was celebrated the completion of the Western railroad connecting Boston with Albany by way of the Berkshire hills. The Boston city officials made a triumphal journey to Albany, and were entertained in the usual style; while the Albany officials returned with their guests to Boston, and were in turn dined and speechified to their hearts' content. Among the guests who went to Albany with the Boston officials were some New Bedford gentlemen, who, "in order to lend point to the astonishing fact that, after leaving their homes in the morning, they would in fifteen hours be in Albany, caused some spermaceti candles to be moulded, which they took with them on their trip; and that evening the rays from those candles illumined the table around which took place the civic banquet at Albany. But the Albanians were not to be outdone. They were to return to Boston with their guests the next day, and in doing so they took with them a barrel of flour, the wheat for which had been threshed at Rochester on the previous Monday (they went to Boston on Wednesday), while the barrel itself was made from wood which, on the threshing day, had been growing in the tree. This flour, duly converted into bread, the authorities of the two cities, and their invited guests, solemnly ate at a great dinner given at the United States Hotel in Boston."

We must now turn our gaze to the great interior, and note the quaint and curious features of a few of the early railroads of that region.

The first railroad in Ohio was the old Mad River and Lake Erie, extending from Springfield to Sandusky (afterward the Cincinnati, Sandusky and Cleveland, and now the Indiana, Bloomington and Western). The first sod was cut at the end of Water street, Sandusky, September 7, 1835, amid general rejoicing and festivity. The first engine run on the road was the "Sandusky"; it was the first in America to which a regular steam-whistle was affixed, and was built at Paterson, New Jersey, by William Swinburne, a workman in the firm of Rogers, Grosvenor and Ketchum. An English mechanical draughtsman, named Hodge, had failed in his plans for the machine, when the American, Swinburne, stepped forward and offered his services, which the firm reluctantly accepted, being sceptical of the value of purely American skill in so new and delicate a piece of work.

In 1831 there was no railroad west of the Alleghanies and south of the Ohio River. In that year the wealthy inhabitants of Lexington, Kentucky, wishing to be thought no whit less enterprising than Cincinnati and Louisville, and even aspiring to surpass those cities in glory—having doubtless heard with wonder of the doings of the locomotive in South Carolina and New York—began to take measures to build a railroad of their own. Frankfort was the nearest available town on the Kentucky River. Accordingly it was resolved to build the railroad to that town. Henry Clay was an influential stockholder in the road. It was finished in 1838 or 1839. The road-bed consisted at first of longitudinal limestone sills, ten, fifteen, and eighteen feet long, with cross-ties laid beneath them every four or five feet. The rails were strips of iron two and a half inches wide, fastened to the stone sills.

by means of lead or sulphur. The frosts of the first winter broke up the stone sills badly, and they were replaced by wood. Some of the rejected sills are still to be seen along the track. The road was laid out in a very crooked manner, the engineers affirming that it was an advantage to have it so, since the conductor could look back along the curves and see his train more conveniently! The cars were at first for passengers only. They were drawn by two horses or mules, and were made to hold four persons, like the old stage-coaches,—which latter, by the way, are still to be found in many parts of Kentucky, the drivers making the echoes of their horns ring again among the beautiful green hills, as they dash along over the finest roads in the world.

The cars of the Lexington railroad were two-story structures, the lower story being for ladies and children, and the upper one for men,—though in warm weather many ladies preferred the top, at least before *the* locomotive was put on the road. This first locomotive was a ridiculous little affair made by a Lexington mechanic. It had no cab, and the tender was an open box-car with room for a small supply of wood, and for a hogshead of water which was filled by pumping from a well at the side of the road. In place of a “cow-catcher,” or pilot, two large beams projected in front and had hickory brooms attached to them for sweeping the track. The blacks regarded the engine with awe and fear, considering it to be the work of the “debbil,” and its disuse was hailed by them with joy. They thought horses good enough for them. When the locomotive was first put on the road, the directors celebrated the event by inviting guests to make an excursion to Frankfort in a “brigade” of little platform cars.



When the excursionists were drawing near to that town it began to snow, and lo, and behold, the engineer took shelter with his locomotive under a shed, and refused to budge an inch further, declaring that the "slick" track would be so dangerous that the train might be derailed! Accordingly, many of the passengers had to foot it home. Frankfort, lying in the river-valley, is at a much lower level than the line of the railroad of those days. So here, as at Albany and Schenectady, the trains were let down the incline by a stationary engine. On one occasion the cable broke, and a train of cars shot down at a fearful rate of speed, knocking out the end of the depot, and smashing things generally. This old inclined plane was afterward supplanted by a series of direct and reverse curves and a tunnel.

The pioneer railroad of the great western prairies was the Northern Cross road (now the Great Wabash). It originally extended from Meredosia, on the Illinois River, to Springfield, in the state of Illinois. Its origin was in this wise.\* In 1837, the Legislature of Illinois appropriated ten million dollars (!) for a magnificent system of internal improvements, and a large share of this was to go to railroads. Work on many of these was begun, but a great financial crash came, and the construction of all of them was suspended except that of the Northern Cross, which was nearly completed, and was speedily finished through to Springfield. The rails of the road were "strap" rails, five-eighths of an inch thick, and were fastened to the wood by ten-penny nails sunk into the rail

\* For the material of this sketch of the first railroad of the Great West, the author is indebted to Mr. A. A. Graham, who published his account of the road in "Potter's American Monthly" for July, 1879.

until the heads were flush with the upper surface. The first locomotive, built by Rogers, Grosvenor and Ketchum, of New Jersey, was landed at Meredosia in the fall of 1838, and on the 8th of November of that year the first puff of a locomotive was heard in the prairies of the West, where to-day the smoke of these ships of the plain rises far off on a thousand horizons, like the smoke of ocean steamships sunk beneath the watery rim of the world. The little locomotive had no whistle, no spark-arrester, and no "cow-catcher," and the cab was open to the sky. Its speed was about six miles an hour, and where the railroad and the highway lay parallel to each other there was frequently a trial of speed between the locomotive with its "pleasure cars" (as they were called) and the stage coaches. Sometimes the stages came in ahead. Six inches of snow were sufficient to blockade the trains drawn by this American engine. A fight between a bull and the engine is narrated by Mr. Graham. One day as Daniels, the engineer, was trundling along with his locomotive he espied "a belligerent Taurus, who sternly faced the train, and with tail in the air, head lowered in a defiant attitude, seemed like the valiant Fitz-James to say:

"This rock shall fly  
From its firm base as soon as I."

"Daniels came up to him, but unflinchingly and defiantly he held his place. Daniels shouted, threw sticks of wood at him and swore, but all to no purpose; the bull had the track and meant to keep it. Daniels backed his train and came up again, making all the noise he could, but this only incensed the bull, and immovably he kept his place. The third time the engineer tried to scare him off by touching him with the engine, but there he stood, master of the sit-

uation. By this time Daniels got mad and said: 'By Dads, I'll try which has the hardest head!'

"The meeting came near being disastrous to both, but Taurus went tumbling down the bank, never to repeat his experiment."

It was the fate of this pioneer prairie railroad to succumb for a time. For some reason it could not be made to pay. The engineer ran the locomotive off the track, burnt out the flues, and finally the unlucky thing was abandoned on the prairie east of Jacksonville, where it lay for nearly a year. It was then purchased by General Semples, of Alton, who had an idea that he could introduce road locomotives on the plains. He put on a new set of wheels, *with tires two feet wide*, changed the engine power, and made one trial trip, from Alton to Springfield. But he had to take along a yoke of oxen to pull his machine out of the mud-holes in which, from time to time, it stuck fast, and so he concluded that that sort of motor would not pay. The wheels made two broad parallel tracks over the prairie, and became a source of great wonder to travellers who crossed them. Some thought that the trail was that of an enormous serpent, and two men actually followed it to Springfield, "to see what kind of a critter it mout be." They found the monster on the prairie below the city, and there it lay until broken up for old iron. But if the Northern Cross railroad thus ignominiously failed, not so did other and subsequent roads. They multiplied apace. In 1846, the Michigan Central road was in operation, and so were many others.

A good idea of the Western railway car of this period may be obtained from the accompanying view of a car of the Michigan Central. It was copied from an original

schedule of rates of freight and fare, and reminds one very strongly of the little Sunday-school book illustrations of one's boyhood days. The roof is low and flat, and we



MICHIGAN CENTRAL RAILROAD CAR, 1848.

shudder to think of the discomfort of the heat in summer and cold in winter (there being no stove) to which the passengers must have been subjected.

## CHAPTER IV.

### THE BANDING OF THE CONTINENT.

The road-making sons of Vulcan making an uninhabited country habitable.

—*ÆSCHYLUS, Eumenides.*

“**F**OR if there were to be no railroads, it was, on the whole, rather an impertinence in Columbus to discover America.\* What is the use of a country sprawling out from Maine to California, from Mackinaw Bay to the Florida reefs, if you are to spend all your life in walking over it?” So think the American people, and their reply to this query is the great web of trunk lines that, together with the telegraph, forms the sympathetic nervous system of the nation and does perhaps more than anything else to compact the several states into one homogeneous commonwealth.

It is hardly necessary to caution the reader against the mistake of the old lady who thought a railroad was called a “trunk line” because it carried trunks. A long railroad, with its numerous branches, resembles a tree-trunk in more than one respect. As the latter carries up nourishment to the leaves from the roots, but produces nothing itself, so does a railroad carry sustenance from the farms of any region to the cities; it is simply a mediator between the two.

\*This allusion to Columbus, by Gail Hamilton, reminds one of Thomas H. Benton's noble conception of a colossal statue of the great discoverer, to be hewn out of the solid granite of the Rocky Mountains, at some point on the Union Pacific railroad, and to point with outstretched arm to the western horizon, saying to the flying passenger, “There is the East; there is India!”

Many of the trunk lines of the eastern states have been formed by the consolidation of smaller early lines. The New York Central, for example, is the consolidation of ten small roads which lay mostly in a direct line, connecting one with another. So the Pennsylvania Central—the largest railroad system in the world\*—leases or controls fifteen other lines, extending through the most productive portion of the country as far as to the Mississippi River. What splendid and powerful corporations are those which operate such railroads as the Midland of England, and the Pennsylvania Central in this country, with their long series of huge bridges and viaducts, their magnificent stations, terminal dockyards, construction and repair shops, their thousands of cars and locomotives and employés, and their income of millions of dollars! These “strong light works of modern engineers” are matched only by such structures as the Chinese wall and the highways of Peru and Rome. To future ages the vast embankments and tunnels of our railroad lines will be such objects of admiration as are to us the famous works just mentioned.

The railroads that sprang into existence immediately after the demonstration of the success of the institution were numerous. At the close of 1832 there were nineteen railroads, either completed or in process of construction, in the United States. These roads, however, were all near the Atlantic seaboard. As late as 1850 Ohio had but one trunk line, *i.e.*, that connecting Sandusky with Cincinnati, and in that year there was not a mile of railroad west of the Mis-

\* The Pennsylvania Central has in its system six thousand four hundred and thirty-eight miles of track. The largest single corporate railroad organization in the world which is under one title, with but one set of officers for the whole, is the Chicago, Milwaukee and St. Paul (four thousand five hundred miles). The longest single line under one management is the Southern Pacific, extending from San Francisco to New Orleans.

Mississippi. The first railroad out of Chicago was that connecting Galena and Chicago, chartered in 1836. The first land-grant of the Government was made to the Mobile and Ohio road in 1848. It consisted of one million acres.

Among the first trunk-roads to secure a princely land-grant were the Central Pacific and the Union Pacific, forming one continuous line. There was splendid audacity displayed in the construction of this trans-continental road. Everything verged on the impossible; everything was on a gigantic scale, as befitted the girdling of the globe. The history, or romance, is a double one. On one side of the rocky backbone of the Continent you see an army of twelve thousand dark specks slowly creeping westward, and spinning behind them as they move a single iron thread. For six hundred miles of the route there is not timber enough to make a cross-tie; the dwelling-houses of the labor-army are built on car-trucks; every supply must come from the rear; the lack of confidence in the enterprise is so great, that the laborers, like the soldiers of Cortez and Pizarro, mutiny and demand their pay in advance. But for five years their steady tramp is heard,—across the boundless plains, up the great mountain range with its whelming snow-drifts (they split the rocks with something better than vinegar), across the hot sands of the waterless desert—until the second army advancing from the west is met, and the last stitch is taken in the earth's long belt. There, near the head of the Great Salt Lake, they lay down a tie of polished laurel bound with silver bands; Nevada sends her silver spike, California two of gold, and Arizona three (of silver, iron, and gold, respectively); the last spike and the hammer that drives it are in electric communication with nearly all the fire-alarm telegraphs in the country; the silver sledge

gleams in the air, and the blow that follows is heard farther than any other blow ever struck by mortal man; and all over the continent the ringing of bells, and the booming of cannon, simultaneously announce the tidings of the feat, while locomotives from either side roll over the place of junction, touch pilots, and mingle their ear-splitting whistles with the general conclamation.

But one half of the story is yet to be told. We have yet to learn how the Central Pacific was built on the other side of the Continent; how the five Sacramento merchants talked over the project in the hardware store of Huntington and Hopkins, at No. 5, K street; and how they turned a deaf ear to the ridicule poured upon them (the project was considered so visionary that bankers dared not subscribe to the stock of the road, for fear of injuring their credit); how they found a route through the snowy Sierras, brought their material around Cape Horn, imported ten thousand Chinese laborers, hurled thousands of tons of solid rock down among the pines by a single charge of nitro-glycerine, bolted their snow-sheds to the mountains, and filled up, or bridged, hundreds of chasms and valleys. "Two thousand feet of solid granite barred the way upon the mountain top where eagles were at home. The Chinese wall was a toy beside it. It could neither be surmounted nor doubled, and so they tunnelled what looks like a bank swallow's hole from a thousand feet below. Powder enough was expended in persuading the iron crags and cliffs to be a thoroughfare, to fight half the battles of the Revolution."\*

And so, through eight hundred miles of uninhabited country, through mountains of perpetual snow and across

\* "Between the Gates," by Benjamin F. Taylor.



an alkali desert, the road was built. The Union Pacific cost about \$39,000,000, and the Central about \$140,000,000; but in the two years 1872 and 1873 the roads saved to the government, in the transportation of postal and war materials alone, the sum of \$3,789,788. And yet this was the road that as late as 1856 had been declared as impracticable as a road to the North Pole. "Suppose a train to be snowed up eight hundred miles from Iowa in November, how are you going to get to it before May?" it was asked. And the point was apparently well taken, for during the first years of the operation of the road, trains were snowed up for weeks at a time. But snow-sheds and snow-ploughs and relief-trains of provisions solved the difficulty. "Your road-bed and your trains will be overwhelmed by land-slides," said the alarmists. How this objection was practically answered will be best illustrated by an example. In 1880 a vast avalanche of earth and rock buried the track near Alta on the California slope of the Nevadas; to clear it away was a month's job, if done by shovel and pick. But here was a passenger-train waiting to move on. In one hour a flume of boards had been made to tap a mountain stream near by; an hydraulic hose was borrowed of some gravel miners; several streams, under one hundred and fifty feet of pressure, were set to playing upon the mass of material; down rolled rocks, trees and earth, a hundred tons at a time, and in forty-eight hours the gold gravel sluicer had cleared the road; the track was replaced, and the train moved on amid the cheers of the liberated passengers.

The Southern Pacific railroad was projected as early as 1845 by New Orleans citizens. The construction of the road was an enterprise only less daring than that of its

predecessor. The Southern Pacific crosses leagues on leagues of hot Sahara desert where dew and rain are rarely found; for months at a time track-laying had to be suspended on account of the intolerable heat; the tools became so hot that they could not be handled; water for the men had to be carried in tank-cars; the fierce mounted Apaches—the red Arabs of that desert—were always hovering near, ready to strike and fly; and often the work of days was obliterated by one of the fierce simooms, or sand-storms, which so darken the sun at midday that through the twilight gloom the red glare of the locomotive's head-light penetrates but a little way. Here were indeed no snow-slides to be encountered, but something as baleful and obstructive; and the miles on miles of sand-fence of the Southern Pacific match the snow-sheds of the Central, while the great tunnel of the latter is rivalled by the Tehacape Pass on its sister road. In this pass the height to be overcome is so great that eight miles of track were laid down in order to attain a distance forward of one and a half miles. Once-and-a-half around the hill the track curls its iron lariat-loops, then doubles on itself like a closely pursued hare, and for a space runs straight backward toward its starting-point—a most cunning piece of engineering audacity.

There is nothing in the history of the two other trans-continental railroads that calls for notice in such a work as this. The history of the Northern Pacific has been written by Mr. E. V. Smalley; the Canadian Pacific is still unfinished. On March 8, 1884, was driven the last spike in the Mexican Central railroad, uniting the ancient capital of the Aztecs to New York and Boston by a continuous line of steel rails. "*Viva la Republica de Mexico!*" cried

the American Consul, as the pilots of the locomotives touched; and "*Viva los Estados Unidos del Norte!*" cried a citizen of Mexico, while the crowd rent the air with responsive shouts of "*Viva.*" A significant ceremony, celebrating an enterprise that portends great changes in Mexico, and changes undoubtedly for the better!

Among scenic mountain roads the Denver and Rio Grande holds a supreme place in America. It is also a marvellous piece of engineering work. The construction of the road was undertaken in 1870, by Mr. W. J. Palmer and others, the three-foot gauge being adopted as one better fitted for mountain curves than the ordinary wider gauge. The road may be called an Iron Poem, of that stern masculine sort that our Western men compose, uttering itself in reverberated thunder up there amongst the clouds and whirling snow of the summit of the world; a stitch stoutly sewed into the green kirtle of the West; a bold challenge of Fate; a bearding of the earth-giants (how nimbly the little black steam-mice run over their faces as they sleep!); a road of weird cañons, of snowy summits old in story, of "tumbled rock-piles grim and red,"

These reckless, heaven-ambitious peaks,  
 These gorges, turbulent-clear streams, this naked freshness,  
 These formless wild arrays. — WHITMAN.

Here, west of Pueblo, is the Grand Cañon of the Arkansas, its Royal Gorge, a sort of Symplegades, or colossal gateway with towering walls of gloom. The skull of the Jötun cloven; beneath, the green ichor of the rushing river; aloft, sheer walls of granite, half a mile in height; the span only thirty feet; far up, a light canopy of blue; no bird, no grass, no tree, no sound but the roar of the stream or the thunder of the train over its cliff-bolted,

hanging bridge; while streamlets of sweet water trickle down the seamed walls, and fall unheeded into the foaming torrent. Elsewhere on the road you have the Black Cañon of the Gunnison, with its flashing cascades, cliffs, pinnacles, towers, and cloves, and its strange mountain-cone of red sandstone, the Currecanti Needle. And there are the roan-colored mountains ("Book Mountains") lifting their vast leaves into the air; and Castle Gate towers aloft with its posts of red sandstone five hundred feet in sheer height. Then through the Wahsatch Mountains you go down to the Salt Lake and the City of the Saints.

Such are some of the wonders of the railways of the trans-Mississippi country. Chicago is not only the great railroad centre of this region; it is the greatest railroad centre in the world. The National Exposition of Railway Appliances held there in May and June, 1883, brilliantly focussed the railway life and activity of the whole country. It was held in the Inter-State Exposition Buildings fronting on Lake Michigan, and covered an area of eleven acres. At night that Aladdin genie, Electricity, flashed out his terrible sun-white eyes in a thousand places at once, lighting up weirdly the jets of water, the tropical palms, and the polished steel and golden brass of objects displayed in every variety of fanciful attitude. Around the main gallery ran every day and hour the cars of the electric railway,\* the baby-rival of steam, and perhaps destined to supplant it in the future. Snow-ploughs, monster locomotives, shops in full blast, model depots, a chime-whistle, game and fish and grain from the North, safety signal-devices, and an "Old Curiosity Shop," containing the first locomotives used in the world, were some of the tempting baits held out by the

\* Described in Chapter IX.

managers of the exhibition. A huge locomotive made for steep-grade work on the Southern Pacific was the object of general admiration. The engine weighs sixty tons, is sixty feet long, and has two sets of cylinders and steam-chests. The quaint early locomotives excited as keen an interest as do the old iron-hooped cannon of leather and wood, used at the battle of Crécy, for the one are as antique in appearance as the other. There was George Stephenson's "Puffing Billy," the veritable engine, the first ever run on the Stockton and Darlington railway, and loaned to the Exposition by the Northeastern Railway Company of England. Then there was the first Canadian locomotive, the "Sampson," brought over from Durham in 1838, by George Davidson, for use in a Nova Scotia coal mine. And, finally, there was on exhibition the "Arabian, No. 1," built by Phineas Davis in 1834, for the Baltimore and Ohio rail-

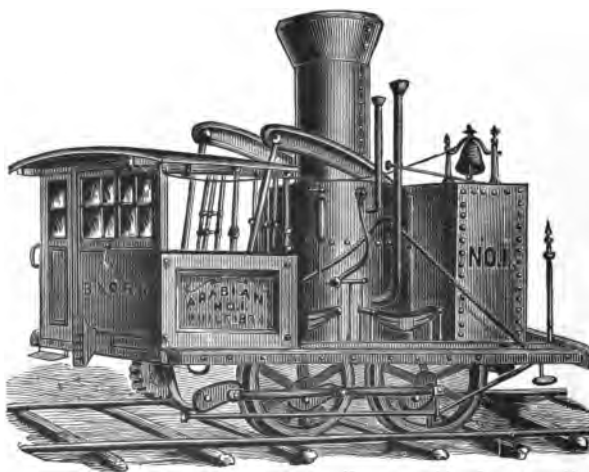

(By courtesy of the "Railway Age.")

THE "ARABIAN."

road, and having the fire-box where the pilot of modern engines is placed. This old relic was subsequently destroyed by fire at the Pittsburgh Exposition of 1883, to the great sorrow of antiquaries. Among the "Old Guard" of engineers present at Chicago were Horatio Allen, David Matthews (said to be the inventor of the spark-arrester, sectional chimney, hand-car, axle-box, and snow-plough, as well as originator of the plan of heating water in the tank of locomotives by means of steam-pipes, and of the device of using sand on the rails); Joseph Whitehead, first fireman on the Stockton and Darlington road "in the days" (as he said) "when a strong head-wind used to bring the locomotives to a stop;" and, last of all, old Tom Galloway, who for over half a century has been a locomotive engineer on the Baltimore and Ohio railroad, has travelled in all more than one million, three hundred and ninety-seven thousand, seven hundred and ninety-six miles, never has had an accident worth mentioning, and is still as hale and hearty as a mountaineer.\*

There is much that is picturesque and startling in the railway life of the Great West. The construction of the roads has always been attended by blood-shedding, and desperate adventures of highway robbers and cut-throats. Nor was it a particularly enjoyable thing first to survey a railroad and then construct it, and run the first trains through a region infested with hostile savages. The following incident will suffice for many similar ones that might be nar-

\* A full account of the Railway Exposition of 1883 may be found in the contemporaneous issues of the "Railway Age," of Chicago, edited by Mr. E. H. Talbott, to whose energy, as well as that of Mr. J. McGregor Adams, much of the success of the Exposition was due. It was Mr. Talbott who first broached the idea of the undertaking in his journal. A pretty good critical account of the various appliances exhibited may be found in the first numbers of "Science," edited at Cambridge, Massachusetts, by Mr. Samuel H. Scudder.

rated of the Indians and their attacks upon railroad trains:

On the 30th of October, 1868, as a freight train on the Union Pacific railroad was steaming leisurely along, about two miles west of Alkali Station, a point was reached where the ties had been cut in the middle, thus spreading the rails. The locomotive was immediately derailed, and the cars completely wrecked, while out of the prairie grass on either side, a force of about one thousand Sioux and Cheyennes suddenly rose up in the darkness, uttering terrific yells. One of the firemen was jammed in between the tender and locomotive, and for three hours suffered such horrible tortures that he implored the engineer to put him out of his misery. All the brakemen fled at the first alarm, but the engineer refused to leave his fireman, whom he was trying to extricate. The Indians next burned the railroad bridge in the rear, for the purpose of wrecking the passenger train which was to follow. But a division superintendent who had come down to the wreck from Alkali Station on a locomotive, and fought his way through a large force of Indians, got to a telegraph station further on in time to warn the approaching train. The superintendent also telegraphed to Fort Sedgwick for troops; but before the cavalry arrived the savages had fled.

But not all the Indians have proved dangerous to the railroads. Many of them have actually become converted into "paddies," working even better than the Chinese, and with as much nonchalance and ease. The Minneapolis and Omaha railroad employs from fifty to a hundred Winnebagoes and Omahas as section hands, and is very well satisfied with their labor.

An amusing Indian story is told of a young man from

the East who was once in charge of a locomotive on the construction line of the Atchison, Topeka and Santa Fé road, below San Marcial. One day the young engineer was ordered to side-track his engine at Gramme, and wait for the passage of a certain construction-train. Now he had devoured with eager and trembling apprehension the numerous stories of Indian depredations that were afloat, and while waiting on his siding kept a sharp lookout for the dreadful savages. His vigilance was soon repaid, for at last he beheld a party of Indians well armed and riding rapidly toward him. To leap from his lookout on the tender into the cab of the engine was but the work of a second. He grasped the throttle-valve and shrieked to the fireman, "Here they come! fill her up!" The fireman was startled by the wild expression on the "tenderfoot's" face, and began shovelling in the fuel. As they bowled rapidly away from the dangerous spot the engineer was congratulating himself a thousand times on his easy escape, when, suddenly, on turning a curve, his engine collided with that of the construction-train, all thought of which had been frightened out of his mind. It turned out that the supposed Indians were, in all probability, Mexicans coming to the place for water. The "tenderfoot" engineer is thought to have returned east, a sadder but a wiser man.

Forest and prairie fires in the trans-Mississippi and northern Michigan regions are dangers to be dreaded by train men. The injury done to forests by sparks from passing locomotives is sometimes vengefully repaid with interest by a furious conflagration which sweeps down upon and devours the train of cars attempting to rush through it. The roar of the fire-tempest among the trees



is described as resembling that of an approaching tornado, and the detonations of the white-meated hickories sound like the cracking of a giant's whip. This is accompanied by a hissing like the sound of frying salt, as the green foliage of the pines is swept away in a white flash of flame, while every few seconds a heavy thunder-crash announces that some forest giant has measured his length across the fiery bed. Trains of cars often succeed in running the gauntlet at full speed, and with wetted roofs; but when they emerge they are generally on fire in several places, and the paint of all the woodwork is cracked and peeled by the heat.

Terrific tornadoes, hail-storms, and water-spouts constitute still greater danger to the navigator of the "iron rivers" that span the western plains. At Kiowa, Kansas, in the year 1878, a locomotive was swept from a railroad embankment by a water-spout, and lost in a quicksand; it has never been found. In the summer of 1880, the town of Monotony, on the Kansas Pacific railroad, was visited by a terrible thunder-storm and water-spout; over six thousand feet of track were washed away, and the prairie lay eight feet under water. During the occurrence of this storm an entire freight-train was lost. It has never been found,—not a trace of it,—although the owners spent two thousand five hundred dollars in the search. It is supposed that the train was swept away and buried under a land-slip. This is surely one of the strangest mishaps ever chronicled! Some future geologist may have a treasure-trove in this buried train, or in its impression on the rock.

The reader will be interested in an account of a wonderful hail-storm encountered by a train of cars in Colorado:

At Potter Station, on the Union Pacific railroad, in the autumn of 1875, a train was just pulling out from the depot, when a storm began, and in ten seconds there was such a fury of hail and wind that the engineer deemed it best to stop the locomotive. The hail-stones were simply great chunks of ice, many of them three or four inches in diameter, and of all shapes,—squares, cones, cubes, etc. The first stone that struck the train broke a window, and the flying glass severely injured a lady on the face. Five minutes afterward there was not a whole light of glass on the south side of the train. The windows in the Pullman cars were of French plate, three-eighths of an inch thick, and double. The hail broke both thicknesses and tore the curtains into shreds. The wooden shutters, too, were smashed, and many of the mirrors were broken. The deck-lights on the top of the cars were also demolished. The dome of the engine was dented as if it had been pounded with a heavy weight, and the wood-work on the south side of the cars was ploughed as if some one had struck it all over with sliding blows from a hammer. During the continuance of this terrific fusillade (a period of twenty minutes), the excitement and fear among some of the passengers ran high. Several ladies fainted, and the wife of the superintendent of the Mountain Division of the road went into spasms, from which she did not recover for over an hour after the cessation of the storm. Several persons sitting on the south side of the cars were more or less injured about the head and face. As soon as the storm abated a little, the matting from the car floors was hung up against the windows, and the train moved on, the wheels crunching through hail-stones drifted so deep as to impede progress for some miles. At the next

station strips of tin were procured and fastened over the windows of the cars.\*

The gigantic snow-ploughs † of the western railroads afford, when in operation, a very inspiring winter spectacle. They sometimes weigh as much as fifty tons. One, owned by the Chicago, Rock Island and Pacific railroad, is stationed, when in use, in front of a car of immense strength; the iron shares resemble the ram of a war-vessel; the plough is hung on linked timbers attached to the car behind, and is raised or lowered from the car-platform by means of lever-screws; behind the plough are two heavy track-scrappers manipulated by men housed within a windowed cab, which also contains a stock of the various tools needed to clear a track in time of snow-drifts. At the Chicago Exposition was shown a huge plough, consisting of a great metal screw working inside an iron box. On the Toronto, Grey and Bruce railroad this novel snow-plough opened a channel through a cut one hundred and fifty feet long, filled with packed ice and snow, the screw hurling the heavy masses to a distance of sixty feet on either side.

Sometimes on the Union Pacific a plough is driven by three, six, or even fourteen engines. It is a magnificent spectacle — this battle-charge of the locomotives. How the earth trembles and reels as with screeching of whistles and level-streaming plumes of steam, the solid line of engines

\*The Denver "News."

†The first successful snow-plough was constructed in 1836 for the Utica and Schenectady railroad; drawings and models of it were obtained by the governments of Austria, Prussia, and Russia. Previous to this but few efforts had been made to keep the tracks clear of snow, and, as a consequence, traffic was almost entirely suspended during the winter months. One early effort to clear the track was made by attaching brooms to a rude car-truck, which was pushed along from behind by horses, while the iron horse remained snugly under cover. Compare what is said in Chapter II about the rude snow-scraper used on the Quincy railroad.

rushes onward and hurls the enormous ram into the mass of ice and snow! Perhaps at first the stubborn compound budes not a foot. Then back, and at it again, and again, and again — until at last, it is done! The mighty avalanche is torn into fragments, and right onward dash the victorious engines with impetuous speed, throwing up a cloud of snow ten feet above their smoke-stacks, and never stopping until they have cut a half-mile path as clean as a sharp knife cuts a honey-comb,— while perchance the belated passengers send up cheer after cheer, and wave their handkerchiefs with delight as they witness the thrilling spectacle.\*

There have been several instances of whole trains lost in the snow-storms of the prairies. In December, 1872, some three hundred and fifty passengers occupying several trains on the Union Pacific road were snow-bound for two weeks, between Percy and Cheyenne — a distance of only one hundred and fifty miles. Tremendous gales had swept the snow into the ravines and excavations of the railroad; snow-ploughs continually ran off the track, and, in short, proved themselves insufficient to cope with the violent gusts of wind and the rapidly drifting snow. The trains had an abundant supply of coal, wood and water, and the railroad company had with wise foresight attached to each train before starting, special cars supplied with fuel, lights and blankets; but food was extremely hard to get. Those who had brought their baskets of delicacies with them had to meet the problem of making five days' supply stretch over twenty days. The restaurants at neighboring stations were speedily bought out by the railroad officials, who were compelled to feed the passengers of one train on halibut and

\* From the account of an eye-witness.

crackers, while others got black coffee and bread, and occasionally some lucky one procured an elk or antelope steak. Whist-parties and story-telling helped pass the time away, and two highly successful balls were held in the back room of a grocery store, the music being furnished by a guitar, a mouth harmonicon, and a fine-tooth-comb!

At six o'clock on the morning of New Year's Day, 1864, a train on the Michigan Central railroad, after having got about seven miles out on the prairies from Chicago, plunged into an immense snow-drift lying directly across the track. At first the powerful engine pushed right on, scattering the snow in glittering clouds to the right and the left, and seeming as if it would pull through victoriously. But soon it moved with great difficulty, and at last, after long labor and struggle, stopped short, unable to gain another foot of headway. There were a hundred persons in the train, many of them women and children; they had with them nothing but light lunches, and many had not even a cracker. As the day wore on they tore up the neighboring fences for fuel for the stoves; but the dry wood aided by the gale soon heated stove and pipe red-hot, and set the car-roof on fire. With great difficulty this was extinguished; but the car was now uninhabitable, and the passengers were all huddled together in the remaining car. It was now two o'clock in the afternoon, and the possibility of a terrible death began to haunt the minds of the snow-bound travellers, when (most welcome sight!) a passenger train on the Michigan Southern line appeared at a crossing some four hundred yards off. It was hailed, and the work of transferring passengers began. The drift was ten feet deep, the storm at its height, and the cold so intense that the faces of the women and children were frozen almost as soon as they

came in contact with the wind, "turning white almost as quickly as if they had been plunged in boiling water." Almost everybody was badly frost-bitten. The new train was itself sixteen hours behind time. Some wedding cake discovered in the cars was confiscated to the necessities of the occasion, and the train, starting afresh with its double load, was soon effectually buried in a drift, the wheels clogged with snow, and the engine frozen up. The night was coming on, and something must be done. Two strong men volunteered to try to reach the city, and did so, after undergoing great toil and danger. They gave the alarm, and sleighs started out loaded with blankets and provisions; but only two of them succeeded in getting to the train. Having unloaded, the drivers started at eight o'clock at night to return in the sleighs, with some of the passengers. However, after travelling for a short time, they became conscious that they were lost in an illimitable labyrinth of snow-drifts running in every direction over the prairie. In the gloom of the night the presence of a drift would not be discovered until the horses were plunging and struggling in it up to their sides; both sleighs were overturned several times, and frequently the occupants, both men and women, were compelled to get out in the deep drifts while the teams were being extricated. Finally, one of the vehicles broke down entirely, and the men were forced to trudge along on foot in snow up to their waists. About half past ten o'clock they saw a light; it was found to proceed from the house of a hospitable German, who received them for the night. In the morning they found that they were only half a mile from the train. As for the people in the cars, the beacon-lantern they had hung out had happily served to indicate their whereabouts to the agent of the railroad

company, who reached them about ten o'clock P.M., with more blankets and provisions. The passengers accordingly passed a tolerable night, and next morning were brought back to the city in sleighs.

Another still more curious instance occurred in 1880, in New Jersey, where a train mysteriously disappeared in a snow-storm, and was not found for two days. The story runs as follows: One day in the last week in December, a passenger train started at three o'clock P.M. from Penn's Grove, on the Delaware River railway, its destination being Woodbury, New Jersey, twenty miles distant. When half the way had been made, huge snow-drifts were encountered, "against which the locomotive bravely and fiercely butted, plowing its way through light drifts which sometimes reached to the top of the smoke-stack." Still not much headway was gained, and the coal on the tender was being rapidly consumed,—when communication was opened with the president of the road. This gentleman sent to the conductor the following plucky despatch: "Use all the fence-rails you can lay your hands on, if your coal gives out. Throw in a barn or two, if necessary. If that fails, take all the pork offered at six dollars per hundred. Keep your steam up, and come through at any cost." Instructions were obeyed, and Woodbury was reached at ten P.M., a funeral cortege having been waiting for the train there since five o'clock. The road having been opened, it was determined to try to keep it so, and the train started back at midnight. At two o'clock it stuck in a drift; telegraph wire blown down; conductor sends messenger across the fields with despatch asking for another engine; but he forgot to state where he could be found, and the powerful engine that was sent out got lost too. In fine, both train

and relief-engine were lost sight of for many hours, and were finally discovered by sleighs sent out to search for them.

During the tremendous snow-storm of January 18 and 19, 1881, in Great Britain, trains in every part of the kingdom were blocked up or snowed under. A hearse carrying a body to be buried was itself buried in a white shroud of snow; a man and cart were buried alive, and a train of ten cars was blockaded in a cutting between the towns of Moulsoford and Goring, and actually snowed under, so that only the funnel of the locomotive was visible; the passengers had been previously removed.

On the evening of December 6, 1882, a train on the little Festiniog mountain road, in Great Britain, was lost in the snow. It seems that as the dusk of evening came on, the train had come to a stand still and large quantities of snow were blown over it, extinguishing the engine's fires. The snow drifted in some places to a depth of twenty feet, and thirty-six hours passed before a relief force of two hundred men, with shovels and snow-ploughs, were able to dig out passengers and cars from their wintry burrow.

One other point must be mentioned in connection with western trunk-lines, and that is the matter of standards of time. This is a topic that could only arise for discussion in a country having very long east and west distances within its limits.\* America is so vast that her railroads must gauge their operations by the movements of the globe itself. As the westward flying cars creep over the green curve of the earth, the passengers find the sun

\*In England there is no such thing as local time. The standard is Greenwich, and all clocks conform to it.



rising later and later every morning, by the time of their watches. This fact, taken in connection with the continually varying standards of railroad time, becomes very annoying, especially to constant travellers. Until the recent Time-table Convention, in Chicago (October 11, 1883), there were fifty-three different standards of time in use by the various railroads. These standards differed from each other by all sorts of odd minutes, and the points on east and west lines where one standard was changed for another, were almost numberless. At the Convention alluded to, an admirable system, devised by Mr. W. F. Allen, was adopted by the representatives of seventy-eight thousand miles of railroads, and it is now used by all the railroads of the United States and Canada. It is spoken of as the "Hour System," for it divides the whole country into four great sections, separated from each other by north and south running lines, or degrees of longitude, which are just one hour, or fifteen degrees apart. The roads lying chiefly in any one section adopt the time of that section, and over eighty per cent of them now use two standards instead of forty. Formerly, in travelling from Boston to Washington, one had to make use of six standards of time,—in other words, set one's watch six different times if one wished to be prompt in catching trains. Similarly, the fourteen railroads centring in St. Louis happened to use six different standards. Now, by the new system, there is but one time for all railways on the Atlantic coast, one time for those in the interior, etc. More explicitly, the sections are called the "Eastern," the "Central," the "Mountain," and the "Western,"—with an extra section added for the benefit of a few Canadian roads, such as the Intercolonial. In the Canadian section, time is that of the sixtieth meridian west

from Greenwich; in the Eastern, the seventy-fifth meridian; in the Central, the ninetieth meridian; in the Mountain, the one hundred and fifth; and in the Western, the one hundred and twentieth. As the change from one standard to another is exactly one hour, it will be evident that in going west or east one's watch will not differ in the minutes, as one passes out of one section into another. For instance, if you start from Boston with the intention of calling in a couple of days, at quarter past ten A.M., on a friend in Buffalo, you will simply leave your watch as it is, and, guided by it, call at quarter past nine, allowing one hour's difference for change of longitude.

In the new system the places where changes of standards occur are large or well known cities. Up to April 9, 1884, seventy-eight of these had adopted the standard time. The time fixed for the first change of clocks was Sunday at noon, November 18, 1883. According to the official report of Mr. W. F. Allen, some fifty million people already use the new standard. It is evident that the employment of uniform time will be a great convenience to everybody concerned. For example, if all cities in the eastern time-section follow the example of the principal ones, the minute hands of all the public time-pieces in Canada, the Atlantic Coast States, and the Middle States will be brought into coincidence with each other and with railroad time, so that all clocks in this vast region will show twelve at the same instant.

## CHAPTER V.

### THE LOCOMOTIVE IN SLIPPERS.

THE railway system in the East, says a witty modern traveller, has already become Orientalized. "It has already put itself into slippers, crossed its legs, shut its eyes, and taken to the chibouque." And thank heaven that it has done so! Let us be grateful that the restless Saxon, even though he go to the East with a locomotive under each arm, can never de-Orientalize that land of poppies and dreams. We have no objection to urge when we read that the first locomotive was landed in 1864, at Ceylon, by means of a bamboo raft, and that it was drawn to the railroad by a team of three elephants; there is a certain piquant fitness in that. And we are resigned to the sleepy railroads of Egypt. But we do wince visibly when anybody mentions the railroad now in operation from Rome to Tivoli, past Hadrian's Villa, or speaks of the iron way from the Piræus to the Acropolis, or shouts in our ear, "Change cars for Nazareth!"\* There is some relief, however, in the fact that the Greek railroad, opened to travel in 1869, was discussed for thirteen years before it could be built, and that, although the Shah of Persia, in 1873, after his visit to Europe, conceded to Russia and to Baron Reuter the right to build each a railroad in the

\* A railroad route has been surveyed from Acre around the base of Carmel, across the plain of Jezreel, with a branch to Nazareth twelve miles in length, and down the valley of the Jordan to Jericho, with a branch to Bethlehem and Jerusalem.

land of roses and of wine, and although some miles of earthworks were actually thrown up at Resht in September, 1873, yet, after all, the Shah had the good taste to back out of the bargain, and revoke his concessions. If the locomotive must supplant the Jinnee in the East, let the conception be leisurely evolved out of the Oriental mind, and practically embodied in a genuine Oriental manner.

So pleads the antiquarian in us. But when we see what the Saxon railroad is doing in Japan and India, we are forced to look at the subject in a different light. The reason then takes part against the fancy, and one is obliged to admit the desirability of the Western institution as a civilizing agent in Asia.

It was a foregone conclusion that the Japanese would be the first to adopt the railroad. The first one in the Mikado's empire, the Tokio and Yokohama, was built by the English, and was opened with imposing ceremonies October 14, 1872. "On that day," says Mr. Griffis, "the sun rose cloudlessly on the Sunrise Land. Fuji blushed at dawn out of the roseate deeps of space, and on stainless blue printed its white magnificence all day long, and in the mystic twilight sunk in floods of golden splendor, resting at night with its head among the stars. On that auspicious day, the Mikado, princes of the blood, court nobles, the flowery 'nobility' of ex-daimiōs, and guests representing the literature, science, art, and arms of Japan, in flowing picturesque costume; the foreign Diplomatic Corps, in tight cloth smeared with gold; the ambassadors of Liu Kiu, the Ainō chiefs, and officials in modern dress, made the procession, that, underneath arches of camellias, azaleas, and chrysanthemums, moved into the stone-built dépôt, and,

before twenty thousand spectators, stepped into the train. It was a sublime moment, when, before that august array of rank and fame and myriads of his subjects, the one hundred and twenty-third representative of the imperial line declared the road open. The young emperor beheld with deep emotion the presence of so many human beings. As the train moved, the weird strains of the national hymn of Japan, first heard before the Roman empire fell or Charlemagne ruled, were played. Empires had risen, flourished and passed away since those sounds were first attuned. To-day Japan, fresh and vigorous, with new blood in her heart, was taking an upward step in life."

Another railroad line runs from Osaka in Nippon to the port of Kobe. It has three or more tunnels, and huge terminal yards. The engineers are English and Scotch, but the subordinate offices are filled by the natives. This is true also of the Yokohama road, where the guards, or brakemen, are mostly "Samourai"—men of good birth—and, dressed in the most approved uniform, perform all the duties of their road in a very satisfactory manner, and have learned to jump in and out of trains while in motion quite as well as American brakemen. An English traveller speaks of the guard on one of the trains as blowing his whistle and waving his signal for departure, to the grave spectacled engineer, with as much self-importance as though ordering a cavalry brigade to the charge. The natives always take off their clogs on the platform and carry them inside the cars in their hands. It is said to be amusing to see how, when travelling, the young Japanese swells try to assume an air of nonchalance, as if they had been used to railroads all their life. The cars are of American pattern, with central aisle. The Japanese take wonderfully to travel by

steam. They scorn a jinriksha when they can ride behind the iron steed. Every train is crowded, especially on Sundays, and pilgrims bound for the capital from Mount Fuji or Oyama hail with joy the foreign engine and train waiting for them at Kanagawa, for the railroad saves them many a weary day's travelling, and much cash besides. The Japanese take great delight in the rapid movement of the train, and although the novelty has now worn off, there are still many who travel over the road solely for the sake of the agreeable sensations experienced. There is, as yet, only one American-built railroad in the empire, the road from Otarunai Harbor at Yezo, to the Paroni coal fields.

The first and only railroad in China had an existence of twelve months. It was built by Messrs. Jardine, Matheson and Company, of Shanghai, and extended from that city to Woosung, a few miles distant. The company could procure no compulsory power, and had to spend a great deal of money in the purchase of land and graves. The great objection brought against the enterprise by the Chinese was that it would depreciate the value of property in its neighborhood, and disturb the spirits of the earth and air. But, as a matter of fact, property along the line increased in value from the very first day (February 14, 1876) that the little engine drew a train of cars. Thousands flocked to see the construction and the subsequent operation of the road. It was fairly blocked with traffic, and was worked at a profit for one year, when, by the advice of the "statesman" Li Hung Chang, the Chinese government bought out the concern, and packed off the plant and rolling stock to Formosa, the Governor of which, Ting Futai, had a great desire to possess a railroad. But as no engineers went

with the material, it was landed on the coast in such a damaged condition as to be useless to the natives, even if they had known how to employ it.

In India the days of the palankeen and cooly, the bullock-cart and pony-post have long been numbered. In 1854 thirty-seven miles of railroad were opened between Calcutta and Pundooah, and since that time thousands of miles have been built, and the whole northern part of the peninsula is now netted with railways. It is recorded that an elephant once charged upon a locomotive while it was drawing a train of cars. The result was very bad for the elephant, as George Stephenson would have said. The animal apparently recognized in the iron mammoth the creature that was to supplant himself as a beast of burden; but his defeat was significant and ominous. The elephant, it is to be feared, is doomed in India.

The stations are strongly built, generally in the Swiss style, and by a wise foresight are made strong enough to serve as a cordon of military posts in case of another native insurrection, like that of the famous Sepoy rebellion. In some few cases, stations are only native bungalows, with picturesque thatched roof. At first, telegraph lines were supported on palm trunks, and when these took root and persisted in putting forth their feathery foliage at the top, they looked very pretty. But the wind and the rain played havoc with them, and so did the natives who kept climbing up to whisper messages to the mysterious singing wire! So also did the white ants prove destructive, and now posts of wood are supplanted by columns of solid masonry. The East Indian railroad, from Calcutta to Benares, might be called the brick and iron road. For in order to guard against the ravages of fire and insects, the ties, the car-

roofs, and the telegraph poles are of iron,\* while track-ballast, stations, fences, and house-roofs are of brick.

As a matter of course the cars are well ventilated, and the conductors rejoice in white jackets and tall pith helmets. On the long trunk lines, such as that between Calcutta and Madras, the first-class cars, which are the only ones that well-to-do foreigners ever travel in, are so made that they can be converted into sleeping cars. Each car contains two compartments, and each compartment has a cushioned settee down either side, with a third crosswise along one end; the other end is occupied by a washing closet with shower-bath. Gentlemen always carry with them a counterpane padded with wool, and a small pillow or two. At night the settee is converted into a sleeping berth by the aid of the counterpane and pillows. At daybreak the train stops to allow passengers time to eat the *chota-hazare*, or early breakfast, and inhale the cool, dewy air before the intolerable heat begins. Etiquette permits ladies and gentlemen to appear during this meal in the light sleeping costume always worn by through travellers. After the early breakfast comes the bath, dressing, and reading of the novel or newspaper. Native gentlemen used to travel first-class, but they made themselves such a nuisance to the English lady passengers by chewing pân, smoking their hookahs, and removing their clothing above their waists, that they were quarrelled with by English gentlemen, and soon by tacit agreement they learned to take the second-class cars, where they make themselves disagreeable to English clerks and soldiers only.

It is the native traveller, however, who offers the most curious study to the stranger. Natives in immense num-

\* For a similar reason the engineer of the San Paulo railroad in Brazil has made use of discarded iron rails for telegraph poles.



bers use the railroad, and almost all travel third or fourth-class. Undoubtedly the railroads of India are invaluable as helping to mitigate the horrors of famine; but a still greater boon conferred by them is the influence they exert in the obliteration of caste. The native brahmin, or high-caste man must travel, and as a rule, he has not money enough to pay for any but a third or fourth-class ticket. But in a car where human beings are packed together like animals, the caste-prejudices of the native have to be kept in the background. Hence it is that in India the division-lines of caste begin to be less strongly marked.

The scenes enacted at the more frequented railway stations of India remind one of the embarkation of our plantation negroes upon the southern river-steamboats. The swart Hindoos arrive at the station four or five hours before the starting of the train. They are always accompanied to the depot by friends, or dependants, numbering from two hundred to three hundred, and the peasant, if his stay abroad is to be for a week or so, often fetches along a bag of rice, one of flour, a supply of ghee (or clarified butter), and a small donkey-load of sugar-cane; for he has heard that provisions are dear where he is going, and he chuckles at his foresight in taking his supplies with him. But the poor fellow finds at the last moment that the freight charges are such as to turn the scales the other way; he cannot, however, throw away his provisions, and so pays the bill with a heavy heart, and many groans and maledictions. There are often as many as one or two thousand natives at a station awaiting the arrival of a train. They are not admitted within doors until about an hour before the train starts. So they squat on their hams outside in the sun, chewing sugar-cane, eating sweatmeats, and chatting with

those who have come to see them off. The noise, confusion, and stench are something wonderful. When the ticket-office is opened the clatter of voices rises into a wild uproar as the crowd rushes in, each man fighting his way forward as best he can. When a native from the back country presents himself at the ticket-window he is told that his fare to such a place is, say one rupee six annas. Now he has all his life been accustomed to have one price asked him, and to pay another, and the state of mind of the English official may be imagined when he is asked if he will not take one rupee two annas for the ticket. If the native does not come instantly to terms he gets a rap from the stick of the policeman who stands near by in order to expedite matters. The Hindoo next rushes to the freight agent to get his baggage weighed; and there again he tries to beat down the price asked. In the mean time the train has arrived, and is now ready to start. But the locomotive whistles and the station-bell rings in vain; only one-half of the crowd is yet aboard. If one of them wishes to find a friend in the crowd he raises so terrific a yell for him—calling him by name—that the sound drowns even the locomotive whistle. It is usually half an hour after the advertised time before the last man is in his place and the train moves off. There are no seats in the cars occupied by the natives; they all squat on the floor, first stripping themselves to the waist. "The third and fourth-class cars," says an anonymous writer, "are one and all distinguished by the quiet and the fragrance of a monkey-house, the roominess of a herring-barrel, and all the picturesqueness derivable from an endless welter of bare brown arms and legs, shaven crowns, and shaggy black hair, white cloaks, red wrappers, blue or scarlet caps and turbans, grinning

teeth, rolling black eyes, and sharp-pointed noses adorned with silver rings so huge that you feel tempted to seize them and give them a double knock,—all exhaling a mingled perfume of cocoanut oil and overheated humanity sufficient to knock down a fireman." It must be noted that the Indian railway companies do not allow any rough treatment of the natives by officials, since the greater part of their income is derived from them.

There are very few railroads in Africa. In 1880 a survey was made for a trans-Sahara railway. The practicability of a route some two hundred kilometres south of El Golea was demonstrated. A reasonable amount of water and a good deal of vegetation was discovered. There is a railroad between Tunis and Goletta, the cars of which have covered balconies at the sides, where passengers may sit in the shade, and enjoy the cool breeze and the prospect. In order to be convinced that the Oriental repose has not been destroyed by the railway, you have only to travel in Egypt over the road from Alexandria to Cairo. About the station every one moves slowly and gently, as if overpowered with drowsiness. There, in the luggage-department is a dark fellow with red fez who stalks about with nose in air, and pays no attention whatever to the clamors of the public for tickets and parcels; here are water-carriers, with their porous earthen jars; vendors of oranges and sugar-cane, and men and women selling curds, heads of lettuce, and coarse dark bread, all of which are eagerly purchased by the Egyptian passengers. While you are conversing with an English engineer, who, in a voice as hoarse as that of a stage-tyrant, informs you that he caught cold last week from being tipped, engine and all, into the Nile,

owing to the submergence of an embankment—all at once a native employé rings a large dinner-bell, which he has been holding on his shoulder; a guard in red fez and red sash closes the car-door; “the blue gowns and bare feet, the water-jugs and palm-mats, and prayer-carpets, and tins, and brass waiters, are all stowed away,” and without any whistling or puffing, the locomotive slides quietly out from the shadowy station into the intense white sunshine, and trundles sluggishly along over its elastic road-bed.

Perhaps your travelling companion is some “imper-turbable old Turk in turned-up red slippers and a sweltering curry-powder-colored pelisse, with grizzly beard, and a huge sealing-wax-looking signet-ring, mounted in silver, on the rugose forefinger of his right hand. And, perchance, in a wash-leather bag, in the breast-pocket of his third jacket, he may carry a large chased gold watch, to which he will occasionally apply his tawny old eyes.” At all the way-stations you pass there is a great demand for water for the washing of hands. After a time the train stops for dinner. An English traveller has thus described a dinner which he ate at a small Egyptian railway-station:

“The dinner at the restaurant was very bad, and ludicrously dear; beef ligneous in fibre, greasy swabs of cabbages, dates thick with flies, were not redeemed by the neatness of the room or the care of the waiters. The place was an outhouse; the butcher, with a goat on his shoulders, bullied through us on the way to his slaughter-house; the dirty Arab servants bounced against each other as they ran about. The only redeeming point of the dinner,—nay, its sweet crowning,—was the concluding dish, the *mish-mish*, a common, but great delicacy in Egypt. It consists of dried apricots, seasoned with scented little clubs

## 100 WONDERS AND CURIOSITIES OF THE RAILWAY.

of cloves, and delicious little papyri rolls of Indian cinnamon." And now, while the reader is smacking his lips over this toothsome dish, we must unceremoniously leave him, and leap at once from Africa into Europe, in order to prepare the next chapter, which is to deal with the peculiar features and picturesque incidents of Continental railway travel.

## CHAPTER VI.

### A MOSAIC OF TRAVEL.

IT is doubtless largely owing to the vast distances traversed, and to the comparatively undeveloped state of the country, that travel by rail in Russia so closely resembles that in the United States. It was not to be supposed that, living in a horribly cold climate, the Russians would deliberately adopt the English car, when they had before their eyes the warm, roomy, and elegant saloon-cars of America. On the contrary, they have not only adopted our system, but they have surpassed it; and to-day, on such a road as the great line between St. Petersburg and Moscow, railway travel has apparently reached perfection, as far as respects luxurious appointments and furnishings. The saloon-cars are of great length (like our Wagner coaches). In the centre is a drawing-room, with tables, sofas, and divans. Opening from one side of this is a passage-way leading the entire length of the car to the iron platforms, which are inclosed with railings. The cars are heated by steam-pipes running from an upright boiler and furnace at one end. Pushing aside heavy curtains you behold three pleasant little private compartments, each containing six easy chairs (the *fauteuil lit*). The same car contains three similar compartments reserved for ladies. There is a light luggage-net for every traveller. A winding staircase leads to a second story or sleeping-saloon, affording from its windows a fine view of

the country along the route. Over the passage-way is a long receptacle for bundles and portmanteaus. The cars have double windows and closely fitting doors; are well ventilated through the roof, and are provided with handsome toilet-rooms, portable card-tables, wax candles, chess, draughts, cards, and books. The train halts at convenient intervals, at stations with clean, wide platforms, and with refreshment-rooms the cheapest and best supplied in Europe. Everything is clean and bright in these restaurants, and the cheer furnished consists of tea, coffee, wines, *liqueurs*, beef, ducks, partridges, venison, sturgeon, caviare, etc., all served by polite and nimble waiters. Enough has been said, doubtless, to convince the American reader that travel in Russia does not now necessarily mean riding in an open sledge with the thermometer at thirty degrees below zero, and the cold wind curdling your blood and fumbling at your heart-strings, while the sleet creeps under your furs and pelts you in the face, and a pack of wolves is howling in your rear ready to devour both horse and man. On the contrary, the journey from Moscow to St. Petersburg is so comfortable a proceeding that many Russians of wealth (loungers and idlers) often travel back and forth between the two cities for the entertainment they receive in the cars and in the restaurants by the way.

In the neighboring country of Scandinavia, the locomotive goes at a very leisurely pace; in other respects there is not much that calls for notice. In Norway the cars are of the English pattern, with doors opening at the sides, and a tank of drinking water is placed above the seats and between the two compartments of each car, with the refreshing block of ice visible through the glass side of the box or tank.

In Sweden the railroads are government property; the road-beds are excellent, and the stations marvels of neatness. Paul Du Chaillu has written an agreeable account of a Swedish railway refreshment-room: "In the centre of a spacious room, the floor of which was spotless, was a large table covered with a snowy cloth, upon which was displayed a variety of tempting dishes, including large fish from the lakes, roast beef, lamb, chicken, soup, potatoes, and other fresh vegetables, different kinds of bread, puddings, jellies, sweet milk, cream, butter, cheese, and the never-failing butter-milk, which many ate first and before the soup. Every article of food was cooked to a turn, and the joints were hot, having just been taken off the fire. Piles of warm plates, with knives, forks, and napkins, lay ready to the traveller's hand; and the whole aspect of the place was tidy, cheerful, and appetizing; one might have fancied a banquet had been spread for a private party. The purveyors had been advised by telegraph of the exact time of our arrival, and, as the railway trains are punctual, unless delayed by sudden snow-storms or accidents, all was in readiness for us. I was much interested in observing the manners of the travellers; there was no confusion. The company walked around the central table, selected from the dishes they liked best, and then taking knives, forks, spoons, and napkins, seated themselves at the little marble tables scattered in the room, rising when they desired to help themselves again. I noticed particularly the moderation of the people; the portion of food each one took was not in excess of that which would have been served at a private table; and every person in the company seemed to remember that his neighbor also might fancy the dish of which he partook. The sale of ardent spirits



in the railway stations being forbidden by the government, only beer or light wines could be procured, and these were served by alert and tidy young girls. From a large coffee-urn placed upon a table, the travellers helped themselves to that beverage; milk was provided without charge.

“The dinner concluded, and the given period of twenty minutes having expired, we stepped up to a desk to pay the reckoning, which was received by the girls. The price charged for this excellent meal was thirty-two cents; an additional sum of six cents was charged for the bottled beer. I observed that the word of each guest was taken without question as to the quantity of wine, beer, or coffee he had consumed, and no one was at the door to watch the people going out.”

As one might expect, railway travel in Germany is very slow, very uncomfortable, but very safe. The charters of most of the railroads were granted under the condition that at the end of thirty years the government might exercise the right of purchasing and operating them. The majority of them have already come into the hands of the government, and it is the policy of Bismarck to get them all into the control of the executive power. There are advantages in having the strong restraining hand of government on the railways. One of these advantages is the thorough and permanent construction of road-beds. It is astonishing but true that *in Germany not a single accident has ever occurred from the breaking of a rail*, for the government compels the companies to replace their rails at the end of a period scientifically calculated to be the limit of safety for rails subjected to the jar of moving trains.

There are no sleeping cars in the “Fatherland,” and all the cars are smoking-cars — except those reserved for ladies.

It is vain to think that you can escape the pipe in German trains, unless you hire a whole car. At the stations, first, second, and third-class passengers are assigned separate waiting-rooms, and are penned up in these until two or three minutes before the train starts, when the doors are unbolted, and a rush is made for seats. The cars open at the sides and are divided into from five to eight compartments. The head-conductor and the sub-conductors are of course uniformed. The conductor-in-chief, after collecting his fares by walking along the gang-plank at the side, retires to a little projecting watch-tower perched on the end of the coach. No drinking water is provided; if there is a retiring-closet it is placed in the baggage-car, and the key can be obtained of the conductor. As there are no central aisles through the German cars, the traveller is obliged to remain in the baggage-car until the next station is reached, when the key is returned to the conductor! The cars on some lines are heated by a preparation of wood, charcoal, nitrate of potash, and starch,—all inclosed in an iron box placed under the seats. The prepared material comes in flat cakes, and eight of these cakes will warm a compartment for sixteen hours at a cost of sixteen cents. An American traveller who travelled from Cologne to Mainz by the "lightning express" says that the train moved at the tremendous rate of twenty miles an hour, and at each of the fifteen stopping places all the conductors and passengers alighted and walked leisurely to the nearest restaurant for beer, so that he calculated that it takes the average German five hours and fifteen beers to get from Cologne to Mainz.

But, besides safety, there are other meliorations. Even fourth-class cars are reserved *für Damen* (for ladies), and

the third-class waiting rooms are (according to German taste at least) jovial and genial places, where everybody is smoking or drinking beer, and at a jolly buffet a flax-haired Teuton girl supplies you with two eggs, a jug of foaming beer, and a nice sandwich, and gives you back change out of threepence. On the railroad between Cologne and Berlin they have introduced the neat French custom of train-lunches. The train between the two cities stops nowhere longer than five minutes; so inquiry is made before the train starts as to who will dine at Frankfort, and when the train arrives at that city "waiters deposit trays in the cars according to the number indicated by slips stuck by the guard on the windows of each compartment. These trays are electroplate with a velveted support to rest them on the knees, and contain a whole assortment of covered electroplated dishes fitted into holes to keep them firm during the oscillation of the train. Removing the lids, the traveller finds a soup or bouillon in one, a cutlet with peas or beans in another, a fine cut of a joint with two vegetables in another, and some stewed strawberries in a fourth. Add a pint bottle of white wine, and such conveniences as a napkin, toothpick, and the usual condiments and bread, and even the stingiest traveller cannot begrudge the half-a-crown which is asked for this neat little entertainment." The tray is handed out at the next station, and the traveller composes himself comfortably to his book or his nap.

Steam travel in Spain is a pretty rough experience. The luxuries of travel are not to be sought in that country. There are long and irritating delays, and at about every stopping place you are amused to see the leisurely fashion in which engineer, fireman, and conductors will roll up cigarettes and never start until the last puff has been

drawn. But on every Spanish train there is a *wagon reservado para Señoras*; and at the stations the refreshing cry, *Quien quiere agua?* mingles with the voice of the vendor of cool, delicious grapes, oranges, and lemons.

The English and the Americans find a good deal of fault with French travelling accommodations,\* but there is much that is agreeable in the management of their railroads. The officials may ventilate the cars badly, furnish some poor ones, rob your luggage occasionally, keep back change, and furnish wretched sleeping cars; but then many of the cars are excellent, and are furnished with carpets and foot-warmers, the officials are courteous, and, above all, you are provided with elegant and digestible lunches. Dickens, it will be remembered, in his "Mugby Junction," hits off with delicious satire the difference between the French and English restaurants of his day. The English ones have improved since he wrote, and the French ones have not deteriorated. The "Missis" of the "refreshment" room at Mugby thus imparts to her employés the results of her tour of observation in France:

" 'Shall I be believed when I tell you that no sooner had I landed on that treacherous shore than I was ushered into a Refreshment Room where there were, I do not exaggerate, actually eatable things to eat?'

" A groan burst from the ladies.

\* An Englishman, writing to the London "Times," growls about a Frenchman with whom he travelled, who smoked a nasty pipe, drank sour wine, and spat on the carpet of the car. But exceptions do not make the rule, and nobody doubts the superficial politeness, at least, of the Frenchman. Englishmen also complain of the red tape of the baggage room. They weigh your baggage, enter it in a book, and write the weight, destination, number, and charge for transportation on a slip of paper, which is handed to you. When you arrive at your destination you cannot get your luggage until trunks, bags, and boxes are all set out in order on long counters.

“Where there were not only eatable things to eat, but also drinkable things to drink.’

“A murmur, swelling almost into a scream, ariz. Miss Piff, trembling with indignation, called out: ‘Name!’

“‘I *will* name,’ said Our Missis. ‘There was roast fowls, hot and cold; there was smoking roast veal surrounded with brown potatoes; there was hot soup with (again I ask, Shall I be credited?) nothing bitter in it, and no flour to choke off the consumer; there was a variety of cold dishes set off with jelly; there was salad; there was—mark me!—*fresh* pastry, and that of a light construction; there was a luscious show of fruit. There was bottles and decanters of sound small wine, of every size and adapted to every pocket; the same odious statement will apply to brandy; and these were set out upon the counter so that all could help themselves.’ \* \* \*

“‘I need not explain to this assembly the ingredients and formation of the British Refreshment sangwich.’ (Universal laughter.)

“‘Well, take a fresh, crisp, long, crusty penny loaf made of the whitest and best flour. Cut it longwise through the middle. Insert a fair and nicely fitting slice of ham. Tie a smart piece of ribbon around the middle of the whole to bind it together. Add at one end a neat wrapper of clean white paper by which to hold it, and the universal French Refreshment sangwich busts on your disgusted vision.’\* (A cry of ‘shame!’ from all.)”

\*Of late the lunch-basket system (already referred to) has come into vogue in France. The following announcement is posted in the stations of one French line:

“MM. the travellers who wish to breakfast or dine are advertised that they will find at the buffet hot meals in baskets for 2 fr., 50c.

“These meals are composed of three dishes, one-half a bottle of wine,

Last of all, let us cross the Channel, and consider some of the more wonderful features of English railways.

Many of the English railroads follow the lines of the old Roman roads, such as Watling street (from Chester to Dover), Foss way, Ermine street, and the Antonine way. It is generally thought by Americans that English cars attain a greater speed than do those in this country. But of late (as we shall see when we come to speak of speed) it has been shown that many of our eastern trains make as good time as the fastest English ones. We are naturally attached to our own railway system. But so are the English to theirs, although the more cosmopolitan and better-travelled Englishmen acknowledge the superiority of our cars, especially as making utterly impossible the outrages and murders so frequent in the closed and isolated compartments of their coaches. In looking over the index of the London "Times," the writer of these pages was astonished to find that during a period of twenty years there was *not a single year* in which many outrages, attempted murders, and attacks by madmen were not reported to have occurred in the closed compartments of English cars. When pickpockets travel by rail and are known by the policemen, they are placed in separate compartments with locked doors. An amusing incident is related of the capture of a thief in an English car. A lady and a gentleman were travelling alone. Presently the man asked the lady if she would oblige him by rising and turning her face to the window, as he wished to make some changes in his wearing apparel. She complied. After a moment he said, "Now, madam, you may resume your

bread, and dessert. MM. the travellers have thirty minutes to take their meals in their cars."

In other words, you procure a lunch-basket at one station, and return it empty at the next.

seat." But what was his astonishment at finding that the supposed lady had also made some little changes in her attire, and was, in short, transformed into a man, as he himself in turn was changed into a lady. A laugh ensued, and the man who had first spoken said to his companion, "It appears that we are both anxious to avoid recognition. What have *you* done? I have robbed a bank."

"And I," said the whilom lady, as he dexterously fastened a pair of handcuffs on the wrists of his interlocutor, "I am Detective J. of Scotland Yard, and in female apparel have shadowed you for two days. Now," drawing a revolver, "keep still."

This incident is told here to suggest the complete helplessness of ordinary English passengers in case they are shut in with dangerous characters in the small compartments of their cars. But notwithstanding that this danger is as plain as the nose on a man's face, the stubborn insularism of the British, and their love of personal exclusiveness prevent them from adopting to any great extent our democratic aisled cars. When American cars were first introduced on the Midland road, people came and looked at them and then went away and took passage in a rival line. Yet our Pullman and Wagner coaches are universally liked in England. Whether our ordinary cars will ever supplant theirs is doubtful. There are good things to be said of the English car. The railway service of Great Britain is the finest in the world. The cushions of the first-class coaches are rich and sober in tone, and extremely comfortable. Everything is done for the traveller's comfort by polite officials, the tickets of passengers are examined just before the train starts, your luggage goes in the same van with yourself, the cars are started gently and gradually, the best roads are

smooth as glass, the speed high, and the tracks carefully guarded by watchmen, by overhead bridges, and by fines levelled against trespassers.

One of the wonders of the world is the underground railway of London — or rather railways, for London is now belted by a nearly complete double circle of these subterranean ways. The only similar works in the world are the underground railway of Constantinople (which is about half a mile long, and cost one million dollars), and the Fourth avenue tunnel in New York city, extending from Forty-second street to Harlem River, a distance of four miles.

The inner circle of the London roads is twelve miles long, and consists partly of tunnels and partly of cuttings (with high walls) opening to the sky. The Metropolitan was the first, and was built for the purpose of affording the Great Western railway a city station at Farringdon street. It was afterward extended under the most crowded portion of the mighty city. Connected with it is the Metropolitan District railway, filling out the western portion of the circle or ellipse, and called the Daylight Route, owing to the number of open cuttings. These great arteries of intramural traffic run either on a level with or underneath the gas-pipes, water-mains, and sewers, and it may well be imagined that all the skill of a surgeon was needed to avoid severing some part of the vast network formed by these conduits. Thrice was it necessary, during the construction, to tunnel under the great "Fleet Ditch" sewer, and yet the passage of the sewage could not be interrupted for a single moment. In case buildings were to be tunnelled under, it was necessary to purchase them, and they were then generally demolished. The underground roads cost from two



and a half to four million dollars per mile, and the Metropolitan now pays four per cent on its capital. The roads act the part of a go-between, or passenger exchange, with respect to the other great trunk lines centring in London, since wherever the underground lines intersect them, quadruple subterranean tracks are laid, that the surface roads may have room to run in their trains and transfer their passengers. In this way a passenger arriving from the north can now at once continue his journey southward, if he so chooses, without carriage transfer through the crowded streets of the city. The lines are worked on the block system of signals, a very necessary precaution where trains follow each other from daylight to midnight, at intervals of one and two minutes. Two or three of the small hours of the night are reserved for repairs, and during this time no trains are run. In 1880 the Metropolitan road carried over sixty-three million passengers. The engines burn either coke or a smokeless coal from South Wales (called Bwlffa coal), and the exhaust steam is condensed in the water tank. But notwithstanding all precautions there is a sulphurous, disagreeable smell in the tunnels, and a dingy atmosphere gives its tone to everything. The trains are almost noiseless, and glide in weirdly out of the darkness to the light of the sunken station, stop for fifteen or twenty seconds, and then rapidly move on again. At the stations time is saved by having the trains so made up that each different class of cars may always stop directly over against a certain portion of the platform, which is labelled "first," "second," or "third" class, as the case may be. This enables people to wait in the place where they can step directly aboard, on the arrival of the train. The cars are lighted by gas.

The year 1876 saw the completion of still another subterranean railroad in London, that of the East London company, extending south-easterly from the Liverpool street Station of the Great Eastern railroad, passing under the warehouses and water-basin of the London docks, thence through the famous Thames tunnel to the New Cross station of the South Eastern railway. This gigantic subterranean and subfluvial structure cost sixteen million dollars, and is six miles in length.

## CHAPTER VII.

### A HANDFUL OF CURIOSITIES.

THE inventive genius of mechanics has exercised itself in the excogitation of a good many fantastic and daring plans for railroads and locomotives. There have been not only railroads under the ground and in the air, but railroads in the clouds, railroads among the tree-tops, and railroads on the ice, and the models of even a submarine railway have been constructed and exhibited. And there have been flying locomotives, locomotives with sails, locomotives on sled-runners, and bicycle locomotives.

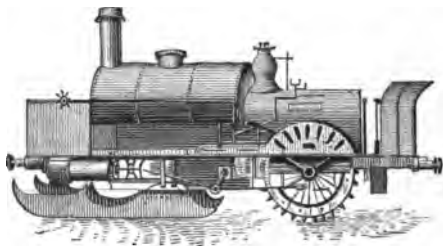

(By permission of the "Scientific American.")

A LOCOMOTIVE ON SLED RUNNERS.

Some years ago a *Locomotive on Sled-Runners* was constructed by the Messrs. Neilson of Glasgow, Scotland. It was employed in Russia for drawing passengers and freight over the ice between Saint Petersburg and Cronstadt. The two driving-wheels in the rear are studded with sharp spikes. The front part of the engine rests on a sledge, which is swivelled, and is turned to the right or left by the wheels working in connection with an endless screw

and a segment rack. The locomotive is said to have run eighteen miles an hour over the ice. From the Russian ice locomotive, the transition is natural to *Railroads on the Ice*. On February 12th, 1879, when the mercury stood twenty degrees below zero, the first train of the Northern Pacific railroad to cross the Missouri River passed over on ice three feet deep. The track was laid on twelve-foot ties, and the cars carried over a number of visitors and a quantity of railroad iron. In January of 1880, a similar road was built across the frozen Saint Lawrence at Hochelaga. A rough bed was first levelled in the ice; then cross beams were fitted in, and upon these were placed longitudinal beams, which were themselves crossed by the ties that held the rails; water was then pumped over the whole structure to freeze it down.

The idea of grading for a railroad through a forest with a cross-cut saw, and laying the ties on the stumps is certainly a novel idea. But it has actually been done, and California can now enumerate among her unique curiosities a *Railroad in the Tree-Tops*. In Sonoma county, between Chipper Mills and Stuart's Point, where the railroad crosses a deep wooded ravine, the trees are sawed off level, and the ties fastened upon the stumps. Of these trees, two are huge redwoods which stand side by side, and are sawed off seventy-five feet from the ground. Upon this firm support cars loaded with heavy saw logs pass over with complete security. The reader will remember the curious suggestion made by Colonel John Stevens, to construct the Erie railroad on piles sunk in the ground. In 1839 a section of the projected road of the Ohio Railroad Company was laid on piles between the towns of Fremont and Maumee. The piles were from seven to twenty-eight feet long,

and were driven ten feet apart in four rows, the intention being to have a double track. Upon the piles were laid longitudinal chestnut sills; upon these the cross-ties, which were surmounted by stringers covered with the usual strap-iron of those days. Fifty-two miles of this curious railroad were built at a cost of sixteen thousand dollars per mile. But the company failing in the hard times that followed the speculative mania of 1836, the road was never completed, nor was a single train ever run over its track.\*

There are several *Wooden Railways* in the United States and Canada. One of these, in the province of Quebec, is thirty miles long. The rails are of maple, four by seven inches, and trains run over them with remarkable smoothness at the rate of twenty-five miles an hour. The road is used for the transportation of timber, and the rolling-stock consists of one locomotive and thirty-five cars. Another wooden-track railway, fifteen and a half miles long, has been constructed by Messrs. Land and Pritchett on the gradings of the abandoned South Carolina Central railroad. It cost the firm twelve hundred dollars a mile, and was built by them to carry the products of their turpentine distilleries to a market.

Very curious are what may be called the *Bicycle Railways*, built with a single rail. One called the "Steam Caravan" was begun in Syria, between Aleppo and Alexandretta. The rail was raised on a wall of masonry twenty-eight inches high, and seventeen and one-half inches broad; on the rail travelled the wheels of the locomotive. The engine and the last car in the train were also to be supported, or braced, by obliquely placed leather-covered wheels travel-

\* For a description of Elevated City Railroads see Chapter X, near end, and for Colonel Stevens's idea see Chapter II, page 32.

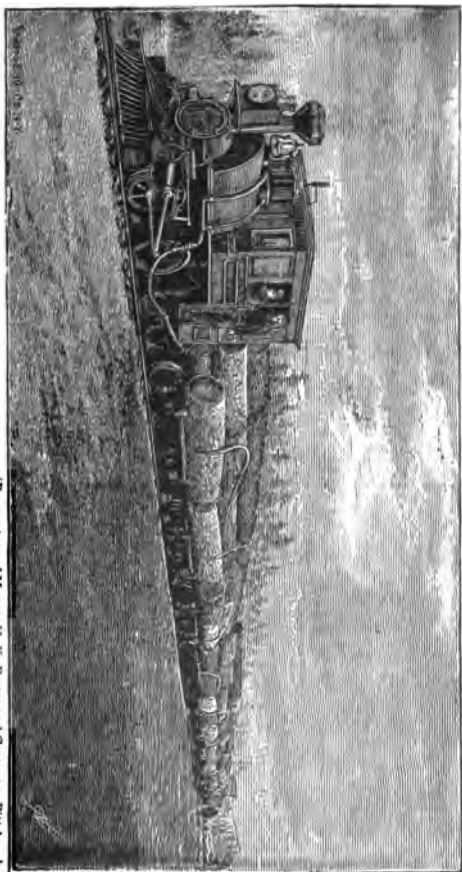

(By courtesy of Messrs. H. K. Forster and Company, Pittsburg, Mo.)  
LOGGING RAILWAY TRAIN.

ling along the sides of the wall; these wheels also to serve as brakes, by the aid of properly applied levers. The "Steam Caravan" road seems never to have been completed. A single-rail, or bicycle, railroad has also been constructed in this country. It is the invention of General Le Roy Stone; was in operation at Phoenixville, Pennsylvania, in 1876, and was exhibited in Philadelphia in the same year. A two-wheeled locomotive has been constructed in Gloucester, New Jersey. The weight is four tons, and the wheels have very deep flanges. This bicycle locomotive was made for an elevated city railroad in Atlanta, Georgia. Similar to this locomotive are the Railway Velocipedes, so many of which are used on western roads. They have a wheel on each track, are light in construction, and are propelled by the feet and hands of the rider at the rate of twenty miles an hour.

There are several *Toy Railways*, or model railways for experiments, in this country and Europe. Mr. Robert Coleman, a young millionaire living at Lebanon, Pennsylvania, has constructed, for purposes of experiment, a miniature railroad one hundred and fifty feet in length. It is in a building erected especially for the purpose. The roadway is circular with a double line of steel tracks extending around the room. The locomotives are about four feet in length, including the tenders. They are of English make, and are perfect little beauties, the cabs being of solid walnut, and the boilers proper and the fire-boxes of wrought steel. The tenders are made of copper, and their supply of water is taken up by little scoops, from vats in the roadway, while the locomotives are in motion. There are patent safety switches, electric crossing signals, safety frogs, etc. The locomotives accurately repeat in miniature every

smallest feature of large engines. Many hours are passed in this building by the wealthy proprietor in experiments as to high and low speed, friction, safety-devices, etc., while his three little locomotives go puffing and panting around the tracks. Mr. Percival Haywood, a gentleman of independent fortune, living near Derby, England, has also built a miniature railroad, with workshops, etc. The track is a mile long, and he has a number of tiny locomotives and cars. His experiments have respect to improvements in army field-railways and military railway plant.

A *Submarine Railway* is probably about the last thing that most people would think of. Yet a Frenchman, Doctor La Combe, has had the audacity to work out the details of such a device, and his models were exhibited at the Palais de l'Industrie in Paris, in 1876. His plan provides for a submarine railway between Dover and Calais. On a road-bed of *béton*, or concrete, three galvanized iron rails are to be placed; two for the track, and one in the centre. To the central rail the car is to be attached by rollers in order to prevent its being derailed by the waves. The boat-car is to be air tight, and driven by a propeller-screw, worked by compressed air. The car is to be supplied with fresh air by a tube running up to the surface of the water where it is affixed to a buoy. A series of buoys on the surface would mark out the track of the car, and in case of any accident it (the car) would float on the surface, when cut loose below. The inventor is very confident of the success of his plan, if it were only tried.

The *Marine Railroad* of Captain James B. Eads (builder of the Mississippi River jetties and the great St. Louis bridge) is to be 112 miles in length, uniting the Gulf of Campeachy with the Gulf of Tehuantepec. The route was



surveyed in 1881, and enough work has been done to secure the generous concessions of aid afforded by the Mexican government. Captain Eads's ship railway is designed to transport ocean vessels across the American isthmus, without unloading. He says that his studies have convinced him that the largest loaded ships may be carried with perfect safety at ten or twelve miles per hour, on steel rails weighing but seventy pounds per yard, the kind used by first-class railroads, and on wheels which shall not impose as great a pressure upon the rails as that of the driving-wheels of a first-class locomotive when at rest; and that no grades need be encountered from ocean to ocean greater than one per cent, or fifty feet to the mile. The ships are to be kept upright by the same means that are employed in dry docks. The propelling power is to be furnished by four locomotives, two on each side of the ship, which is itself to rest on a broad, wheeled cradle, or low car, running on many rails. At either ocean ships are to be elevated to the cradle by a vertical hydraulic lift, instead of by the incline originally contemplated.

The idea of *Atmospheric Railways* originated with old philosopher Papin, of Blois, in France. His idea was that of conveying carriages along a large tube by means of a vacuum and atmospheric pressure. The plan was revived in 1810 by the Englishman Medhurst, and later was in practical operation at the Crystal Palace, Sydenham. The tube in this latter case was a quarter of a mile long, and the car within it was used for the conveyance of passengers solely. The tunnel, or tube, was of brick and was nine feet high and eight feet wide. The piston that propelled the car was rendered almost air-tight by means of a fringe of bristles extending nearly to the surrounding brickwork of

the tunnel, and to its floor. A fan worked by a steam-engine both exhausted and compressed the air. The motion of the car was pleasant, and the ventilation ample. The best pneumatic railway was patented in London in 1834 by an American named Pinkus. He made his air-tube only forty inches in diameter, placing it under the car, to which it was attached by a vertical arm working in a continuous slot. The tube extended the whole length of the railway, was firmly fixed to the roadbed, and only the vertical arm moved forward, pushing the car with it. The vertical arm or lever was operated by a pneumatic piston in the tube. In 1846 five miles of road on this plan were in operation between London and Croydon. The device has not proved of practical value.

A *Flying Locomotive* was constructed by Mr. Moy and successfully operated at the Aeronautical Exhibition in England in 1868. The engine weighed thirteen pounds, and in connection with aero-plane wheels was made to lift itself, and forty pounds in addition, to a height of six inches, in continuous flight around the room.

The device of a chariot or *Car with Sails*, spoken of by Bishop Wilkins in his "Mathematical Magick," and at various times made use of on the level roads of Holland, Spain, and China, has been twice or thrice revived in America. One instance has already been mentioned.\* One of the most successful of these sailing cars has been devised by Mr. C. J. Bascom, of the Kansas Pacific railroad. It has been used for years as a hand-car on that road. The mast is eleven feet high, and the triangular sail has two booms. On the plains a speed of forty miles an hour has been attained by the car, with the wind right abeam (on the

\* See page 39.

side), the sail close hauled, and the road full of disadvantageous curves.

The sailing-car tried on the South Carolina railroad in 1830 was very successful. A trial-trip was made in it by fifteen gentlemen. The experiment afforded high sport, according to a local paper. The car flew over the track at the rate of fourteen miles the hour, with the wind blowing very fresh right abeam, and driving the car in either direction with equal speed. When going at twelve miles an hour, the mast went by the board, carrying with it the sail and rigging, together with several of the crew. The damage was repaired, and the wind presently changing, it was discovered that the car could sail within four points of the wind.

Two other railroad curiosities remain to be described in this chapter.

Captain C. W. Williams, U. S. A., has recently invented a *Telegraphic Car*, or moving telegraph office. It was successfully tried on the Atlanta and Charlotte Air Line in 1882. A line of electric wire laid alongside the track communicates with certain key-blocks and metallic rollers fixed to the ties. On the bottom of the telegraphic car are two long strips of metal (one on each side), which, when the car is in motion, pass over the successive rollers on the cross-ties, depressing them as they pass. The rollers are at such distances apart that the strips on the car always touch one or another of them. When the rollers are depressed by one of the car-strips, electric communication is established with the wire along the track, and the deflected current passes up into the car and down on the other side through the second car-strip to the main line again. By this invention not only may trains communicate with each other at any time,

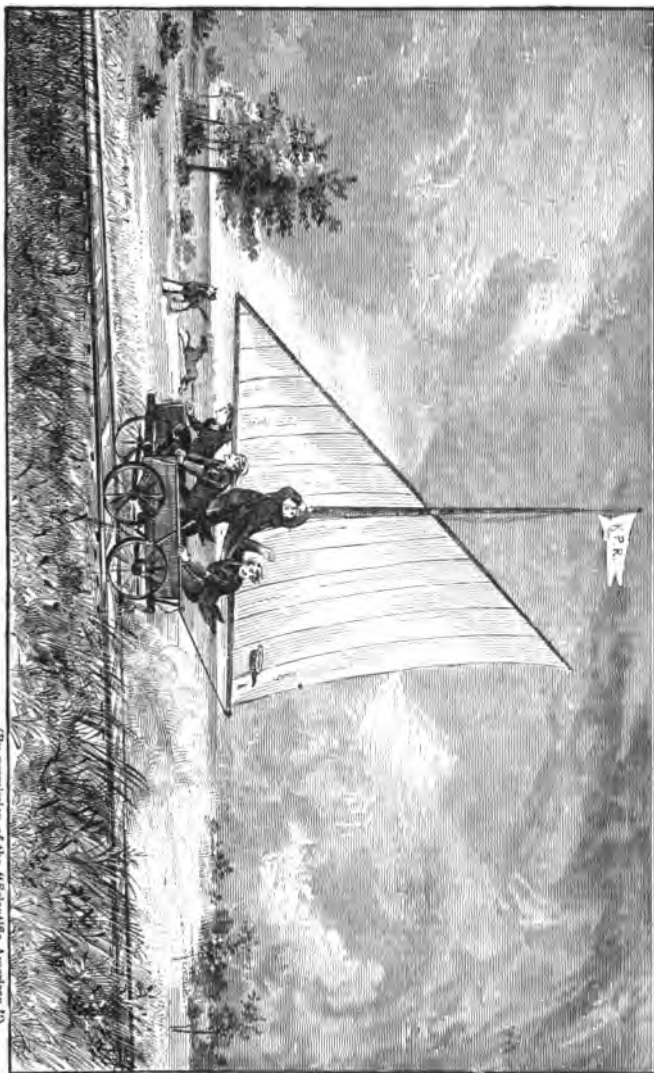

SAILING CAR (KANSAS PACIFIC RAILWAY).

(By permission of the "Scientific American.")

but the train-despatcher may be in constant and close connection with every train on his line.

Prof. P. H. Dudley, a citizen of the United States, after working for eight years at the invention of a piece of mechanism to be used for the inspection of tracks, finally perfected a machine of the following description: A strip of plain paper, about twenty inches wide, is fed from a roll into a small machine, where it passes under a complex set of overflowing pens which are connected by rods and springs with the car wheels below. For every fifty feet of track passed over by the *Dynograph Car*, the paper moves one inch. The automatic machinery makes a complete register on the paper strips of the state of the track: it shows the condition of each joint, frog, and grade-crossing, and reveals at a glance any inequalities or undulations in the rails. After a railroad has been examined, the operator shows his chart to the road-superintendent, who then sees instantly just where repairs are needed. There is also connected with the machine an electrical attachment for indicating mile-posts and stations; this is worked by hand. There are only two of these machines in existence. One is operated by the inventor, and was exhibited at the Railway Exposition in 1883, and the other has been sent to Australia. The machine used by the inventor is placed in a special car containing, besides the work-room, a library, parlor, dining-room, kitchen, bed-room, and store-room; and in this car the inventor travels over the country on his tours of inspection.

## CHAPTER VIII.

### MOUNTAIN RAILWAYS.

THE locomotive has proved to be a good climber, and the defiant whinny with which he announces his arrival has startled the eagles and the wild goats up among the crags and clouds of many a mountain pass in the Alps, the Andes, and the Rocky Mountains of America. There are five sorts of mountain railways,—gravity roads, rack-rail roads, counterpoise roads, roads with stationary engines, and the ordinary traction roads.

Pennsylvania has several gravity railroads—all used for the transfer of coal to shipping points. That of the Delaware and Hudson Canal Company\* lies among the picturesque Moosic Mountains, two thousand feet above the sea. It was built in 1828, was the third practical railroad in the country, and constituted a part of the gigantic scheme of the Philadelphia Quakers, William and Maurice Wurts, to connect the coal mines discovered by them in the valley of the Lackawanna with tide-water on the Hudson River, *via* their canal. The railroad filled up a gap seventeen miles long separating the mines from the mountain terminus of the canal. The hilly nature of the region determined the character of the railway. It consists of eight inclined planes from one mile to four miles in length. From the summit to Carbondale there is an uninterrupted descent, down which

\* For historical matter relating to this road and to the Mauch Chunk road, see Chapter II, "The First American Railroads," pages 35-38.

the cars rush at a speed of sixty miles an hour. An enormous fan at the summit engine-house regulates the rate of descent by atmospheric pressure. In 1877 the first passenger cars were put on the road, to the great enjoyment of visitors and citizens. The ride is one of the most peculiar and exhilarating in the world. You are reminded of the magical car of the subterranean Egyptian temple, described by Tom Moore in his "Epicurean." Here you are, travelling for miles, up hill and down, through beautiful scenery, and no visible agency to propel you. East and south the landscape stretches away for sixty miles; at Shepherd's Crook you whirl around the summit of a gorge four hundred feet in depth, with a series of cataracts leaping down three hundred feet among the hemlocks, and the valley of the Lackawanna, spotted with towns and farms, stretching out far and wide in the distance. There is no dust, no smoke, no cinders, no whistle, no insolent official; you only feel that some gigantic piece of clock-work is drawing you smoothly onward, and you lie back in your seat in tranquil enjoyment, and yield yourself to the novel illusion of magical power.

Another gravity road in Pennsylvania is that of the Pennsylvania Coal Company, near Scranton. It extends for thirty-three miles through magnificent mountain scenery.

A curious variety of coal railroad was the Switchback road—a portion of the Mauch Chunk gravity road (described in Chapter II). It was constructed on the occasion of the discovery of the Panther Creek mines. The cars, running smoothly on a down grade, were made to run uphill by the momentum they had acquired, until they were stopped by the steepness of the grade; then the attraction of gravitation would pull them back again down-hill. But when they arrived at the bottom or central part between

the two hills, a switch, working by a spring, threw them on another track, and they continued down the mountain in a different direction. The next switch would send them in the original direction, and so they zigzagged it down the mountain. This old switchback system is now disused,—a series of curves having supplanted the inclines.

One of the wonders of the world fifty years ago was the old Portage railroad across the Alleghany Mountains in Pennsylvania. It formed a link in the system of canals and railroads constructed by the state, at a cost of seventeen million five hundred thousand dollars, between the cities of Philadelphia and Pittsburgh. In 1838 David Stevenson, an English civil engineer, said of the Portage railway, that, in boldness of design and difficulty of execution he could compare it to no modern work he had ever seen, excepting perhaps the roads through the passes of the Simplon and Mt. Cenis. The whole distance of three hundred and ninety-three miles between Philadelphia and Pittsburgh consisted of four sections. First there came the horse-railroad from Philadelphia to Columbia — eighty-two miles; road completed in 1833. There were inclined planes and stationary engines at each end of this section; over the intermediate portion of the line the cars were drawn by horses. It seems a strange idea to us that people should ever have clung to the thought that the state ought to build a railroad, and that private individuals should have the right to traverse it with their own cars drawn by their own horses, and pay toll as on common roads. Yet such was the plan actually tried for two years upon the Philadelphia and Columbia railroad. One who assisted in the construction of the road tells us that the drivers employed by various firms were a rough and stubborn



set of fellows, and, as the officers of the railroad had no power to use compulsion, one of the drivers would often block the track for a considerable time, refusing to go either forward or backward. The usual remedy was to have the refractory fellow arrested, taken before a magistrate many miles off, and fined according to the law. The farmers were bitterly opposed to the introduction of the new-fangled locomotives, and fought stubbornly for the private-car system. But in 1834 the locomotive came (from Boston where it was built), and soon no more horses were to be seen on the road.

At Columbia, passengers and freight were transferred to the boats of the eastern division of the Pennsylvania canal, which extended to Hollidaysburg, at the eastern foot of the Alleghanias (a distance of one hundred and seventy-two miles). To this canal the Juniata and the Susquehanna contributed of their sparkling waters. The canal boats were built in sections, and at the foot of the mountains were taken apart, loaded on wheeled trucks and so run over to Johnstown on the other side, *via* the Portage railroad. From Johnstown to Pittsburgh extended the western division of the canal. It remains to describe the "Portage" division, in length thirty-six miles, and crossing the mountains at Blair's Gap, the summit of which was two thousand three hundred and twenty-six feet above the sea. The road passed over eleven levels, ten inclined planes, and four viaducts, and through a tunnel which was the first of its kind in America. The trains of four cars each were drawn up and down by stationary engines, one train ascending as the other descended. The rails (rolled in Great Britain) were chained to cross blocks of sandstone. The road was operated for

twenty-one years without a serious accident; but in 1854, the opening of the mountain division of the Pennsylvania railroad rendered useless this great work, built by our fathers to last, as they thought, for generations. To-day only ruined locks and broken bridges remain to tell the story of the quaint predecessor of the Pennsylvania Central railroad.\*

The old Mountain Top Track of Virginia (opened in 1854) was a temporary portion of a proposed through line to the West. It was four miles in length, and crossed the Blue Ridge at Fish Gap, at an elevation of one thousand eight hundred and eighty-five feet above tide water, and with the astonishing average gradient of two hundred and thirty-six feet to the mile. The peculiar climbing engines made for the road rested on six driving wheels, that the adhesive power of the engine might be as great as possible; and for the same reason the water-tank was placed on the boiler, and the supply of wood stored in side-boxes placed on the foot-board of the locomotive. These devices, with the aid of air-brakes, friction-brakes, and sand, enabled the locomotives to draw their loads up the steep grades without an accident.

The predecessor of all the modern pleasure railways for the ascent of lofty mountains is the Mt. Washington cog-rail track (finished in 1869). It ascends the mountain at an average grade of one thousand three hundred feet to the mile. When the inventor, Sylvester Marsh, of Littleton, New Hampshire, asked his state legislature for a charter, it was granted amid much merriment, and the

\* Mr. Solomon W. Roberts, the civil engineer of the Portage road, gives interesting reminiscences of his connection with it, in the "Pennsylvania Magazine of History and Biography," for 1877, pages 370-393. See also James Dredge's "History of the Pennsylvania Railroad," London and New York, 1879.

suggestion was made that the gentleman also receive permission to build a railroad to the moon. There are, in all, six ways of stopping the train on the Mt. Washington road. The friction-brake consists of an iron band encircling each wheel, and tightened at pleasure. There are also atmospheric brakes at the side of each car. Not a single passenger has ever been injured on the road. In 1869 the axle of the driving-wheel of the locomotive broke, but the train was instantly stopped without further damage. The only accident recorded is that which happened when some thoughtless person started an empty car down the track from the summit; the car shot down with terrific velocity and was shattered into splinters at the bottom.

The immediate successor of the Mt. Washington road was that of the Arth Rigi, or Rigi-Kulm, three-fourths of a mile long, opened in 1873. One of the engineers of the Rigi road, Herr Riggenschach, had visited the Mt. Washington railroad, and afterward modelled his road upon that. Rigi-Kulm is the highest of the seven peaks called Rigi, and the view from its summit is as magnificent as that from Mt. Washington. Another railroad ascends from Vitznau, on Lake Lucerne. The funicular counterpoise railroad up the Vaudois Rigi is the boldest work of its kind in the world, the ascent being three feet in five. On level ground the locomotive of the Rigi-Kulm road looks almost as if it had broken down behind and were resting on its fore-legs (or wheels). On a level it looks as much out of place as a seal on land. The boiler looks like a huge beer bottle placed vertically. The sides of the tender are of wire, for the sake of lightness. The seats of the car all face downhill, and foot-stools serve to keep the passengers from sliding off their seats. In going up, the car precedes the loco-

motive, and follows it in descending, no couplings being used. To guard against the train jumping the track and being hurled down the dizzy precipices along the route, a projecting edge runs along each side of the central cogged rail, and the engine and car are provided with strong rods, the ends of which are bent in such a manner as to pass under the projections. Any jump or jerk of the train is, therefore, made impossible by the pressure of the rods against the under surface of the projections.

Switzerland has at least two other inclined railroads—the Uetliberg, overlooking Lake Zürich, and that on the flanks of the Giessbach. The latter is double-tracked, and is worked by the equipoise system. The excess of weight needed in order that the descending car may pull up the ascending one, is a little over a ton. The weight added consists of water, which is filled into a receiver in the car just before it starts from the top of the mountain, and is automatically emptied when it reaches the foot.

The city of Lyons, France, has inclined tramways between its different quarters. In this case also, the descending car balances the ascending one. The inclined railways of Cincinnati, Ohio, are worked by stationary engines. The first of these Cincinnati railways was built in 1872.

The latest inclined railway is that of Green Mountain, in the island of Mt. Desert, Maine. It resembles the Mt. Washington road, except that there is no trestling, the track timbers being bolted to the solid ledge. The idea of the road originated, it is said, with a very stout lady, whose superfluous flesh rendered it an impossibility for her to enjoy the splendid view from the summit. She had ascended Rigi-Kulm and Mt. Washington by railway, and expressed her wonder that no one had thought of a similar

means of ascending Green Mountain. A young Bangor lawyer, named F. H. Clergue, overheard her remark, was struck with the idea, and eventually formed a company by which the road was built in the spring and summer of 1883.\*

Brazil has an inclined railway at St. Paul. It is operated by wire ropes, and was built by James Brunlees, the English engineer.†

Perhaps the most striking of the mountain tracks is that which audaciously climbs the smoking crater of world-renowned Vesuvius. The road was opened June 6, 1880. A broad and splendid highway leads zigzagging up to the foot of the cone, where, on a level spot on the west side of the mountain, is situated the lower station, or depot. Straight away up the cone from this point stretches the track, looking like a gigantic ladder, mounting into heaven at the appalling angle of fifty degrees (average). The upper station is a simple but tasteful shed, placed about one hundred steps from the rim of the smoking and rumbling crater. About midway the inclination reaches sixty-three degrees, which to most people seems practically perpendicular, and the sensations experienced during the two minutes required to pass over this portion of the track may be better imagined than described. The road is double-tracked, and there is a counterpoise of cars, one up and one down. These are worked by a stationary traction engine. The boiler of this engine was drawn up the carriage road by twelve horses, one of which died from the effects of the strain received. The huge pulleys that work the cars were pulled up the slippery cone by the united efforts of ninety men, and once at the top they were of service in hoisting other

\* See also "Science," April 4, 1884.

† Further particulars of this road are given in the "Railway Review," Chicago, Oct. 20, 1883, page 612.

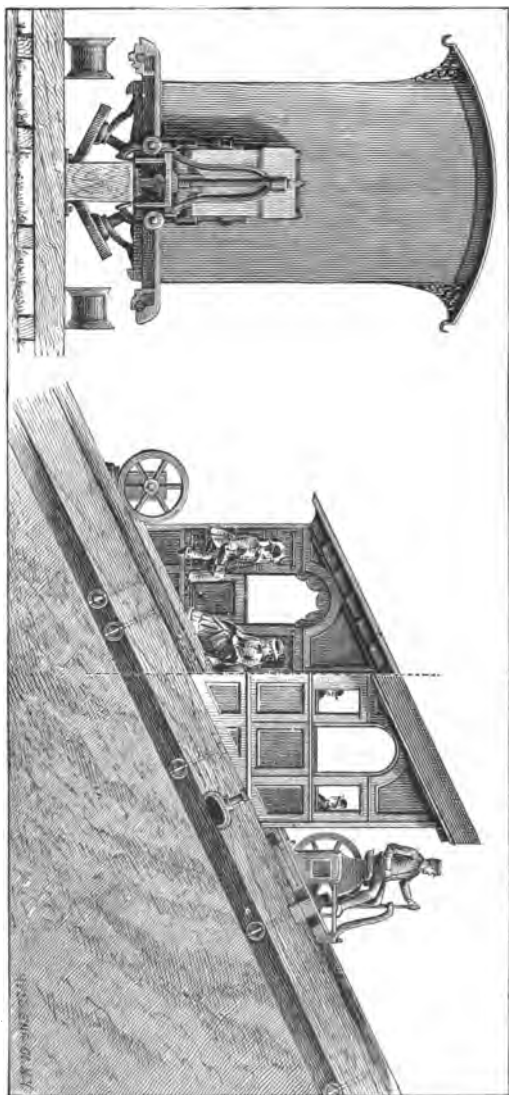

MT. VESTVIUS RAILWAY CAR.

material. There was great perplexity at first in the minds of the contrivers of the road, as to where the water for the engine was to come from. But the constructor, Dall Ongaro, excavated two huge cisterns, and then laid broad stretches of red tile on the surface of lava crusts and cinders to collect rain water and conduct it into the receptacles prepared. The joists of the track are bolted to the solid lava. A single cogged rail is placed on a continuous beam, about three feet high, and beneath the car is a single large wheel running on the rail; but the car is steadied by two other wheels placed obliquely to the bottom of the car, and running on a projecting edge of the road-beam. The railway cost one hundred and fifty thousand dollars, and is insured against the volcano (!) by an Italian company, for one hundred thousand dollars.

The most famous mountain railways with ordinary traction are, in Europe, the Semmering, the Brenner, the Mt. Cenis, and the St. Gothard; in North America the Central Pacific and the Denver and Rio Grande, each described in Chapter III; and in South America the Calláo, Lima, and Oroya railway.

The Semmering railroad between Vienna and Trieste was the precursor and prototype of the great Mt. Cenis undertaking. It is a magnificent engineering achievement, its peculiar feature being its great viaducts; these, together with its tunnels and snow sheds, or covered galleries, made its cost double that of the later Brenner line. The gradient of the Semmering is one foot in forty.

The Brenner railroad, completed in 1867, extends across the Alps from Innsbruck to Botzen, connecting Bavaria with Italy. It climbs over the pass at a height of four thousand, seven hundred and seventy-five feet, passing

through twenty-three tunnels on its way. In ascending from Innsbruck a deep and wide lateral valley is met with; the road thereupon turns short, and, clinging to the face of the mountain, winds around until it has encircled the side valley, and then enters the opposite mountain at a point directly in front of that where it turned a few moments before, only considerably higher up. Let us see how a writer in "Chambers's Journal" describes this achievement: "The difficulty and its solution may be well realized by imagining a railway cut in the face of a long row of houses (which must be supposed to represent one side of the main valley). This railway starting from one end of the row at the basement level gradually rises, in order to pass over the roofs (that is, the head of the pass) of another row of houses at right angles to and at the end of the first row. In its course it encounters a side-street, the lateral valley, with no outlet at the other end, and which is too broad to be spanned by a bridge. Now the line at this point has reached the second floor; and to get to the opposite houses and pursue its course, it turns a sharp corner, runs along one side of the blind street, crosses it at the further or blind end by merely clinging still to the houses, returns along the other side, rounds the corner into the main street and resumes its course. During this *détour* the ascent has been continued uninterruptedly, so that on the return of the line to the desired opposite corner it has mounted to the third floor. Applying this illustration, the reader will perceive the ingenious yet simple solution of the difficulty.

"The effect on reaching the first corner of the lateral valley is most remarkable. The line is seen at the opposite corner far above the traveller's head entering a tunnel: and how he is going to get there is a puzzle which he hardly



solves before he finds himself on the spot looking down on the corner he has just left, wondering how he ever came from there.

“ But even this striking instance of engineering triumphs is eclipsed by a portion of the line on the other side of the pass. Pursuing the direction he has already come, the traveller has stopped in the descent at Schelleberg, a small station perched at an enormous height above an expansive valley, when he perceives a village five hundred feet almost perpendicularly below him, which he is informed is the next station. It would not take long to reach this village (Gossensass) by a direct descent, but in a train he has to run far past it, always descending, then turn completely round, and run back again in the direction he has come from, but now on a level with Gossensass. But at the point where this evolution has to be made occurs another lateral valley, much longer than the first alluded to; and this time one which it is desired to cross, as Gossensass lies, as it were, on the basement of the house on the third floor of which is Schelleberg. The train proceeds, therefore, to turn the corner into the side street as before; but without pursuing the street to its end, it suddenly dives into one of the houses, makes a complete circuit of its interior, and emerges in the opposite direction; returning to the corner whence it started by means of the same houses, but on a lower floor. The appearance of this engineering feat is quite bewildering; and after tunnelling into the hill on the sharp curve, and then finding himself proceeding back toward the place he has just come from, the traveller experiences a difficulty in believing that the line parallel with him, but almost over his head, is the one he has just been passing over.”

The St. Gothard railway was completed in 1880, after six years of labor, and the expenditure of forty million dollars. It extends from Immensee in Switzerland to Chiasso in Italy. There are fifty-six tunnels, with an aggregate length of twenty-five miles. "The locomotive," says a recent writer, "scuffles up a steep road for a while, then thoughtfully approaches a mountain that is too hard to climb, and, instead of skipping along the edge and eluding it, plunges boldly into it, makes a complete circuit in a spiral tunnel, and comes out two hundred feet above where it went in. This adroit trick is resorted to seven times, and in one big mountain the locomotive actually accomplishes two circuits of a mile each, rising in corkscrew fashion, and emerging triumphant up where the eagles brood." Nobody can pass over such a magnificent road as this, with its fifty-six tunnels, its thirty-two bridges, and dozen huge viaducts, without being impressed anew with admiration for the power and skill of man, and still more with reverence for the stupendous snowy mountains, and sounding cataracts of nature. Nor are the natural beauties of the pass injured by the railway, which rather adds to the picturesqueness of the scenery by its bridges and terraces. There are some masses of debris from the tunnels, which are now somewhat of an eye-sore, but nature will soon drape them with beauty.\*

We have not yet spoken of the great St. Gothard Tunnel on this railroad. It is the longest tunnel in the world (nine and one-fourth miles), being about one and a half miles longer than the Mt. Cenis tunnel. The cost was twelve million dollars. The motive power that enabled

\* From certain outlooks on the St. Gothard road the height is so great that cattle pasturing far down in the valleys seem no larger than ants on a tablecloth.

the fifty drills to advance twenty-one feet a day was compressed air; and this as it escaped took back with it the deleterious gases and the vitiated air thrown off by the explosion of the dynamite, and by the bodies of the laborers. During the prosecution of the work three hundred and ten laborers were killed, and eight hundred and seventy-seven wounded. The originator and first constructor of the road and tunnel was Louis Favrey, of Geneva, who died before the work was completed.

The idea of the Mt. Cenis tunnel was first broached in 1832 by a Mr. Medail. The plan of using compressed air for working drills, and of employing mountain streams as a power for compressing the air was the idea of three young Italian engineers — Sommellier, Grandis, and Grattoni. On Christmas Day, of 1870, the working parties met in the heart of the mountain, and the two sets of excavations did not vary more than one foot and a half from the same level. The tunnel is seven and seven-tenths miles long.

As far back as 1820 the idea of a tunnel through the Hoosac Mountain began to be discussed. There being no railroads at that time, it was intended to make the tunnel the passage-way of a canal to connect the waters of the Atlantic with those of the Erie canal. In 1852 the Troy and Greenfield Railroad Company was incorporated for the purpose of constructing an iron way through the mountains and along the Deerfield and Hoosac Valleys. Work on the tunnel was begun in 1852 with a groove and core machine for drilling the rock. This machine proved worthless, and, after eleven years of various vicissitudes and fluctuations of fortune and suspensions of labor, a new start was taken in 1863. This time a drill was used that had been invented by Charles Burleigh, of Fitchburg. It consists simply of a

cylinder and piston worked by compressed air, and driving a drill at the rate of three hundred strokes a minute. Several of these drills were operated at the same time, and Deerfield River supplied the power. Ten years these lightning-swift Burleigh drills plied their task, and then daylight shone through the tunnel (November 27, 1873). The rate of progress was doubled after the discovery of nitro-glycerine; but still the delays had been long and vexatious, and the cost of the work amounted to fourteen million dollars. One of the greatest triumphs of modern civil engineering was the meeting of the various excavations of this tunnel on planes separated from each other vertically by only five-sixteenths of an inch! America beat Europe in this respect, for the difference in the Mt. Cenis tunnel was one foot and a half. The problem was, first, to run a perfectly straight line across the mountain, to serve as a basis for trigonometrical calculations. In running this line a broad path was cut through the forest, and sighting-posts set up, both on the Hoosac and on neighboring mountains. Repeated surveys were made in all states of the atmosphere, and the line finally determined upon was indicated by bolts fixed at intervals in the solid rock. In order to furnish two new faces upon which to drill, and at the same time provide for the permanent ventilation of the tunnel, a great central shaft was sunk at a cost of half a million dollars and four years' work. It will be seen, then, that after the completion of the shaft, there were four parties of men at work, hewing away there blindly in the heart of a great mountain, yet relying so firmly on their calculations that they never for a moment doubted that they were not all working in one straight line, and on one and the same level, and that in the course of

years they would meet. During the sinking of the central shaft (one thousand and twenty-eight feet deep) a terrible accident occurred. A tank of gasoline, which stood near the hoisting apparatus, caught fire and instantly enveloped the shed and the apparatus in flames. Thirteen men were at the bottom of the shaft. All communication with the hoisting apparatus was cut off, and presently a mass of burning timbers, steel drills, and other tools fell down the shaft upon the heads of the unfortunate men. Even if the burning timbers had not been sufficient to kill them, the waters would have done so, for immediately upon the cessation of the pumping it rose rapidly around them. They all perished, and their bodies were not recovered for a year. During the quarter of a century that the tunnel was in building, two hundred lives, in all, were lost. Mr. N. H. Eggleston, in the "Atlantic Monthly," for March, 1882, describes the sensations of those who descended the central shaft: "At every descent of the bucket it seemed as though those in it were being dashed down the dark pit to almost certain destruction. Speed was necessary, and the machinery was so arranged that the descent of over a thousand feet was made in a little more than a minute. The sensations experienced by those who descended the shaft were peculiar. First, there was the sensation of rapid, helpless falling through space in the darkness; then, as the speed was at last abruptly arrested, it seemed for a moment as though the motion had been reversed, and one were being as rapidly elevated to the surface again." The same writer, after remarking that now that the tunnel is finished and in use, a perpetual cloud of smoke pervades it, each of the forty trains a day adding its quota, so that it is impossible to see more than a few yards in either direction within the

bore, — continues as follows: “No artificial light, not even the head-lights of the locomotives, can penetrate the darkness for any considerable distance. The engineer sees nothing, but feels his way by faith and simple push of steam through the five miles of solemn gloom. If there is any occasion for stopping him on his way through the thick darkness, which may almost literally be felt, the men who constantly patrol the huge cavern to see that nothing obstructs the passage, do not think of signalling the approaching train in the common way. They carry with them powerful torpedoes, which, whenever there is occasion, they fasten to the rails by means of screws. The wheels of the locomotive, striking these, produce a loud explosion, and this is the tunnel signal to the engineer to stop his train.”

The most stupendous feat of mountain engineering since the building of the road through the Simplon Pass has been accomplished by the American engineer, Henry Meiggs. The Calláo, Lima and Oroya railroad, constructed by him for the Peruvian government, crosses the Andes by a tunnel at the enormous height of fifteen thousand, six hundred and forty-five feet, or nearly three miles above sea level, being a point only one hundred and thirty-six feet below the icy summit of Mt. Blanc. This is indeed *A Railroad among the Clouds*, and the whistle of the locomotive is heard at no higher point on the globe.\* It is not the first great road in Peru. Centuries ago all the difficulties that beset the courageous modern engineer were met and conquered in this land of stupendous scenery, by a now vanishing race, and the remains of the royal road of the Incas yet testify to the magnificence of an empire, only to be compared with

\*The Denver and Rio Grande narrow gauge road crosses Fremont Pass at an altitude of eleven thousand, five hundred and forty feet, being the next highest railroad in the world.

that of the Romans and the Aztecs, in the elaborate organization and discipline of its people, and the grandeur of its public works. The great road of the Incas was conducted over mountains of perpetual snow, through galleries cut for miles through the stubborn rock, over ravines filled up with solid masonry, and over rivers and dizzy chasms by means of great suspension bridges swinging in the air. There were mile-stones at regular intervals, and guide-posts through the sandy wastes, while trees, and odoriferous shrubs, and fountains along the sides, offered their refreshment in unstinted measure to the weary traveller. But the empire of the Incas has passed away, and we are now called upon to admire the mechanical skill and daring energy of a plain American citizen who comes from a land where all are Incas.

Up and up, through some of the most gloomy and sublime scenery on earth, zigzags the iron road, rising four thousand, nine hundred and ten feet in the first thirty-nine miles, spanning the terrible gorge of Los Infernillos, crossing the famous Verrugas viaduct, darting through its sixty-one tunnels, climbing, climbing, higher and higher among the crags, up toward the gigantic snow-peaks that soar into the everlasting blue on every side, until at last the great summit tunnel is reached, "Tuñel de la Cima," a cavern three thousand, eight hundred and forty-seven feet in length, bored through an icy plateau which is still far below the summits of the great peaks around it.

The difficulties encountered by the workmen in the construction of this Peruvian road were many and disheartening. All the material had to be transported up the mountains on the backs of mules; in some places the road-bed could be hewn in no other way than by lowering the

laborers by ropes over the face of the cliffs; at the summit tunnel the extreme cold and the rarefied nature of the air, together with the continual percolation of snow-water, made the progress of work very slow and discouraging; only natives of the mountains could work there at all, and even they suffered extremely from vertigo, bleeding at the nose and ears, and sickness at the stomach. During the seven years that the building of the road was going on,\* ten thousand Chinese and Chilian laborers died from the effects of the climate and from epidemic diseases. Here indeed was there need of an iron will and an indomitable purpose, and the triumph of these over such terrible obstacles lends to the story of the building of the Andean railroad an interest as inspiring as that produced by the story of the Central Pacific.

It may easily be imagined that the steep grade and the numberless precipices of the Lima and Oroya road are well adapted for producing a thrill of pleasure or terror, as the case may be, in the nerves of those for the first time traversing the road from the summit downward. Mr. J. E. Montgomery in "Scribner's Monthly," for August, 1877, gives a vivacious account of the descent of a party of men in a hand-car from a point near the summit to the plains. (It is from his article that the facts in the preceding account have been taken):

"At Anchi, twelve thousand feet above the Pacific, the hand-car is loaded with its freight of six adventurous sight-seers, closely braced together. \* \* \* As we descend in our rough vehicle, at the rate of sixty miles an hour; flying

\* It was finished in 1877 as far as Oroya, beyond the mountains. It is intended that this railroad shall connect the Atlantic and Pacific Oceans, and open up to commerce the great Amazonian Valley.



across aerial viaducts, or dashing through sepulchral tunnels; threatened now to be crushed between converging mountain-walls, or precipitated from pendulous terraces, the foaming Rimac emulating the maddening speed; now glancing back to take a last look at the glistening pinnacles of the receding Andes; or straining eagerly forward to catch the first glimpse of the royal city of the plain and the shining ocean, the magnificence of the scenery and the magnitude of Mr. Meiggs's achievement break upon us with fresh force, and not for any peril of the way would we forego the exhilaration and novelty of the trip. Far otherwise was it with one of the party, a stately commodore. He who would face unflinchingly a whole broadside of murderous missiles, sprang from the car after ten miles over the wildest part of the route, declaring that nothing would tempt him to repeat such a foolhardy experiment. For the rest of us the excitement and exhilaration of this mode of travel became so attractive that we often went up to Anchi for the sole purpose of making the down trip."

## CHAPTER IX.

### THE VERTICAL RAILWAY.\*

THE fascination of applied science is nowhere more directly felt than in our modern methods of transit from place to place. The bicycle, with its premonitory tinkle and tiny signal lantern, the sumptuous steamship, the palace car, the passenger elevator — which of all these is the most interesting vehicle of locomotion it were hard to say. But certainly, in respect of smooth and noiseless movement and general comfort, the elevator (or “vertical railway,” as its inventor called it) leads all the rest. It is only some ten or twelve years since the vertical railway began to come into general use in the large cities of this country and Europe. A score of years ago, in the United States, buildings were rarely carried up more than four or five stories, and the necessity for freight and passenger elevators was not very great. To-day the great height to which buildings are carried makes the necessity for some kind of rapid and easy vertical transit almost imperative. Cars and platforms hoisted by steel ropes and steam machinery have hitherto supplied this want, and in spite of the popular delusion that a high percentage of risk attends their use, and in spite of the lingering belief of hardy stair-climbers that they are an effeminate and unnecessary innovation, the manufacture and sale of them proceed in a continually increasing ratio.

The story of the invention of the passenger elevator has

\* First published in “Harper’s Monthly.”

never up to this time been told, and the present chapter is therefore a new contribution to the history of inventions.

Steam hoists of one kind or another for the lifting of freight have been in use for perhaps a century. In America the first man to manufacture platform freight elevators seems to have been Henry Waterman, of New York city. As early as 1850 one of his machines was in use by Hecker, of New York. The Tathams had them in 1853, and at about the same time either Waterman's machine or some very like them were in use in the establishment of Harper and Brothers. A cut of Waterman's machine, made from a rough sketch, is given on the next page.\* The elevator was operated by means of a lever within the car (or rather within the frame-work of the car: the first *closed car* was designed by Otis Tufts). The lever took the place of the modern hand rope (or shipper rope) and served to throw the driving machinery into or out of gear. Waterman's shop was in Duane street, near Centre. About the same time that he was making elevators in New York, George H. Fox and Company, of Boston, were also building them and sending them to various parts of the country. The worm gear was used by this latter firm in 1850, and wire ropes in 1852, as well as the rack on the guide beams.

In 1857 the firm of William Adams and Company, Boston, put sixteen freight elevators into the newly built granite warehouse called the State Street Block. These elevators were at first worked by hempen ropes, and the shafting that conveyed the power extended continuously through all the stores of the block. Other early inventors and patentees of portions of elevator machinery were Mr. E. G. Otis, of Yon-

\* The original sketch is in the possession of Mr. Charles Whittier, president of the Whittier Machine Company, of Boston. The author is indebted to the courtesy of Harper and Brothers for permission to use this and the following cut in the present work.

kers, New York, and Mr. Cyrus W. Baldwin, of Brooklyn, New York. The experiments and inventions of the latter gentleman have brought hydraulic elevators to a state of great perfection.

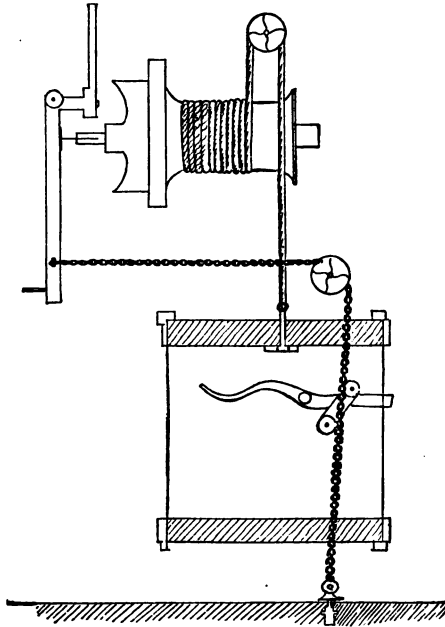

WATERMAN'S ELEVATOR.

Accidents were continually happening to the early elevators, owing to the breaking of ropes. It was an accident to an elevator of his own make that led Mr. Albert Betteley, of the firm of William Adams and Company, of Boston, to the invention of the air-cushion safety device, considered by many as the best of such devices. The accident alluded to happened at the store of Emmons, Danforth and Scudder, in the State Street Block. The elevator platform, loaded with

seven boxes of sugar, had fallen from a great height into the cellar beneath the hoistway, and the pulleys and gearing at the top had been flung clear over upon the neighboring stores. Mr. Betteley was summoned to the scene. He, of course, expected to find a complete wreck in the cellar; but what was his surprise to find the boxes of sugar scarcely injured! He set his wits to work, and soon reached the conclusion that, as the cellar was nearly air-tight, the rapidity of the descent of the platform had compressed the air so as to form an *air-cushion*, which had broken the violence of the fall. After experimenting with a model, and satisfying himself of the truth of his surmise, Mr. Betteley took out a patent for an air-cushion. Otis Tufts used to jocularly call this "patenting a hole in the ground," in allusion to the air reservoir formed beneath the elevator. The object of the invention was to check gradually the momentum of a falling car by making the hoistway nearly air-tight, excavating an air-reservoir at the bottom, and, if desired, building the bottom of the car in a parachute form. This air-cushion device is now universally used in connection with dumb-waiters, and also somewhat extensively in connection with passenger elevators. It will be alluded to again when we come to speak of elevator perils.

To return to the elevator proper. The name of Otis Tufts has just been incidentally mentioned. It is to the brilliant genius and energy of this Boston inventor (now deceased) that the credit is due of inventing and constructing the first passenger elevator in the world driven by steam power. His "Vertical Screw Railway" was patented by him August 9, 1859, and the first one constructed was put up in the same year in the Fifth Avenue Hotel, New York. The hotel was then in process of construction (William

Washburn, architect; Paran Stevens, Hiram Hitchcock, and others, lessees). An exactly similar screw elevator was soon after put into the Continental Hotel in Philadelphia—a hotel also leased to Paran Stevens. These two machines were the only screw elevators for passengers ever constructed.

People would not at first believe a vertical railway a possible thing. Mr. Hiram Hitchcock, the present proprietor of the hotel, says, in a private letter to the writer, that “hundreds, even thousands, of persons visited the elevator daily. Men of note such as the Prince of Wales, the Prince de Joinville, and others, as well as eminent foreign engineers and scientific persons, were greatly interested in it.” The object of the inventor was to produce a machine which should be perfectly safe, and he succeeded in doing so. The screw consisted of a great solid iron shaft twenty inches in diameter, and cast in sections. It extended to the top of the building, and was not enclosed in any

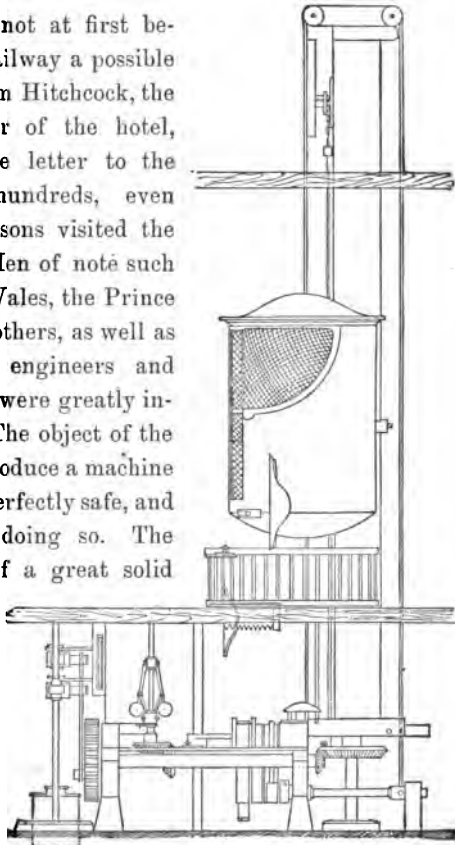

THE FIRST PASSENGER ELEVATOR.

hoistway. A huge iron nut with screws encircled the shaft. Within the nut were rollers running upon the upper side of the thread of the shaft screw. In the language of the inventor, "The rollers were virtually carriage-wheels travelling upon a rail wound spirally along a cylinder." Upon the nut rested the car. The nut did not turn round, being prevented from doing so by a spur attached to it, and moving vertically with it along one of the guide rails. When the shaft was rotated the rollers inside the nut wound upward around the great spiral thread of the shaft, and thus by a continuous movement elevated the nut, and the car with it. A slot in the nut enabled it to pass by the stays that held the shaft to the wall. The car was square and closed. The governing rope passed through the car. There was an automatic stop, a friction brake, automatically closing doors, a fluid retarder, and a second set of rollers travelling directly upon the body of the cylindrical shaft in order to steady the movement of the nut. The fluid retarder requires a word of explanation. The descent of the car was effected by its own gravity, but the descent was subject to continual acceleration. To correct this the fluid retarder (also called pitcher-pump) was invented. It was made on the principle of water escaping from an aperture. When the car reached the top of the building, the gearing which automatically reversed the movement also set in operation the fluid retarders. The elevator was perfectly safe, since the car could not get off the screw. But it was very expensive (costing twenty-five thousand dollars), and was, moreover, rather slow and clumsy. Letters patent of this invention, with specifications and drawings, were filed by Mr. Tufts in the Great Seal Patent-office, in London, on the 19th of March, 1860, through the patent agent Richard A.

Brooman, 166 Fleet street. In 1875, the Fifth Avenue screw elevator gave place to a modern rope elevator, to the regret of many who had for thirteen years admired its massive proportions, its stately movement, and its perfect safety. When removed, it was still in excellent condition. Mr. Darling, one of the present proprietors of the Fifth Avenue Hotel, has invented a rotary retarder, which is used with their rope elevator, and works admirably.

We now come to the passenger rope elevator. The screw elevator was evidently not the thing. May 28, 1861, Mr. Tufts patented an improvement on the old rope elevator which, combined with various previous elevator patents of his, formed the passenger elevator substantially as it now exists. His great and radical improvement consisted in providing *a number of ropes, each of which would sustain five times the weight of the car*, the strain on these ropes being equally distributed by a system of levers. Previously there had been but one rope, which was continually breaking. To-day there is hardly a passenger elevator in the world without two or more ropes "yoked" to the car. The first one constructed for Mr. Tufts, and placed in the American House, in Hanover street, Boston, in 1868, has its car suspended by six steel ropes, each tested to a ten-ton strain. The elevator with its engine was constructed by Moore and Wyman in the most solid style, and has run for fourteen years without an accident. A brass plate in the car has upon it the words "Vertical Railway," as well as the dates of Mr. Tufts's various patents. At the end of the first seven years of the running of this elevator a new steel rope was substituted for one of the old ones, but the old one was found to be uninjured.

The intervention of the civil war put a complete stop to



the introduction of the new invention, and it was not until about 1870 that rope elevators began to come into general use. A good many of the old patents have been allowed to expire, *i.e.*, they have now become common property. Europe is behindhand in the use of this invention. Many elevators are, however, in use there, and quite a number of American make are annually sent over to France, Germany, and England. The Charing Cross Hotel and the Langham Hotel in London have direct-acting hydraulic elevators, *i.e.*, the car rests directly upon a piston working in a water-cylinder. This simple form of hydraulic elevator is much used in this country also. The machines are operated by water-pressure from a city main, or by tanks in the top of the building. A great many have recently been put into the houses of wealthy residents of the Back Bay region in Boston, as well as in Providence and New York city. The huge tower at the Paris Exposition in 1878 contained a single piston elevator, a tube being sunk (as usual) to a depth equal to the height to be traversed — in this case two hundred and eighty-three feet. The triple wire cables were eight inches in diameter. The upward flight of the great wingless bird was performed in two minutes. A passenger hydraulic elevator costs about twenty-five hundred dollars, and one for freight about sixteen hundred dollars. A steam elevator costs (engine, hoistway, and all) between five thousand and seven thousand dollars.

Passenger elevators travel at a speed of from one hundred to two hundred and fifty feet a minute. The total distance travelled in a year is often as much as three thousand miles. Cars lighted by gas have attached to them long rubber gas tubes which rise and fall with the car. A wire sus-

pended in the same manner carries the electric current to the annunciator in the car. Some elevators have indexes which show one waiting to ride just where the car is at any given moment. There are also registers to show the number of trips made. Many elevator engines are constructed on the principle of the worm and worm gear. The winding-drums are scored to prevent friction of the ropes against each other. If the motive power is supplied by a stationary engine, the governing rope in the hands of the operator shifts the belt from one pulley to another to reverse the movement of the car; in case the motive power is supplied by a reversible steam-engine, the governing rope is attached directly to the valve of the steam-chest. The counter-balance weights attached to cars save expenditure of power on the part of the engine.

There have been some strange experiments in the way of elevators. One of the most curious was that tried in the present New York post-office building. Reference is had to the twelve huge telescopic hydraulic machines in use for a few years — eight of them to handle the mails, and four for passengers. They were much like a sliding spy-glass, with the car on the small end. The three polished wrought-iron slides worked through water-tight stuffed boxes. By means of a rope passing through the car, water was admitted through a valve to the lower end of the tubular structure — the car then rose. Descent was effected by permitting the water to escape. The irremediable defects of the machines were, first, that the pressure of water in such long tubes was continually bursting and deranging the stuffed boxes; and second, heavy loads could not be lifted to the top of the building, owing to diminished pressure in the small

upper tube. These structures are now supplanted by the machines of Otis Brothers, of New York city.\*

It is an instinct of men to feel a peculiar horror about falling from a great height. Perhaps our anthropoid ancestors were troubled by falling from trees; hence our nightmare dreams of falling over precipices and the like, inherited from early times. As to elevator accidents, it is stated by the best authority that only one man in all New England was ever killed while in a closed passenger car. Everywhere accidents occur through people heedlessly falling down elevator wells, or by persons trying to climb on moving elevators, or by their putting their heads where they have no business to be. A negro was once sent upstairs to bring down an elevator; he found its door locked. In trying to climb through the transom into the car he took hold of the guide-rope; the car started; when people came upstairs, they found his head on the floor of the car, and his body in the hall outside. At the Mechanics' Fair in Boston in 1881 an elevator boy left his station to get a drink. When he returned he supposed the elevator to be where he had left it, and stepped backward into the well, and was killed. The only instance that has come under the notice of the writer of these lines of persons being killed while inside a falling car is the case of the accident to the direct-acting hydraulic elevator in the Grand Hotel in Paris some three or four years ago. The machine had very heavy counter-balance weights to overcome a very heavy piston. But somehow the iron plate that attached the car to the piston broke; the car flew to the top of the building, breaking the counter-balance

\* Since the above was written hydraulic elevators have become quite popular in New York, and have been placed in many of the large buildings recently erected (1884).

ropes, and then fell to the bottom, killing four persons. This is an exception. Most accidents occur, as has been stated, through carelessness; yet many of them are due to unprotected hatchways, and other kinds of neglect to provide safety apparatus. The law obliges owners of elevators to protect their hoistways by hatches and railings on each floor. But too often there is laxity in these matters on the part of inspectors of buildings.

As a matter of fact, however, there is a remarkably small percentage of accidents connected with the vertical passenger railway — not one tithe of those occurring on horizontal steam railways. Most elevator accidents occur in connection with unsafe and flimsy freight elevators. In one year there were in Boston only sixteen accidents all told, and only one hundred and twenty-four in all the New England States in the same time. The fact is that there are in use so many brakes, extra steel ropes, clutches, automatic stops, and air-cushions that it is next to impossible for a well made elevator to fall.

Some years ago a Chicagoan (Colonel A. C. Ellithorpe) patented some improvements on Mr. Albert Betteley's air-cushion, such as an air-valve, rubber apron, etc. On the occasion of one of the first tests of the colonel's improved air-cushion, namely, at the Parker House in Boston, in the year 1880, a serio-comic fiasco occurred, which came unpleasantly near being serious alone. All things being in readiness for the experiment, eight persons walked into the car, among them the Boston agent of the air-cushion. The ropes were cut; the elevator fell with a thunderous rush and roar that were heard a block away; the pressure of the compressed air sent the glass of the doors flying into the halls; the dust raised obscured the sight; and the eight men

were soon "laid out" in the office, one of them being also "laid up" for some two months, another having his neck cut, and all being considerably "shaken up," to say the least. The trouble was that the air reservoir at the bottom had not been excavated deeply enough, and no provision had been made for the partial escape of the air by means of valve or wire grating. These things were soon remedied, both at the Parker House and elsewhere. Many hundred air-cushion reservoirs have since been constructed beneath elevators, and many marvellous tests have been made, almost all others being as conspicuously successful as the Parker House experiment was conspicuously a failure. At the Chicago Exposition in 1880 the ropes of a car weighing two thousand eight hundred pounds were cut, a number of visitors having first entered it. The car fell one hundred and nine feet; the passengers walked out smiling, and the crowd cheered with wild enthusiasm. In other experiments baskets of eggs taken into the car were unbroken, and persons held in their hands glasses of water, not a drop of which was spilled. When a car falls on such occasions as these that have been mentioned, it stops somewhat suddenly, although gently, when it reaches the air-cushion, and then settles slowly to the bottom of the well.

The vertical railway has made a great change in the appearance of our great cities. Twenty years ago they presented an outline that was comparatively flat and uninteresting. To-day it is very different. The towering masses of their great buildings and the variety of their architectural forms give to their contour a much greater interest, and impart to it a high degree of picturesqueness.

To the real-estate owner the vertical railway has proved a priceless boon. The value of land in the crowded centres

of different branches of commerce has been materially enhanced by it. In order to derive the highest available income from such property it has become incumbent on the land owner to build as far up toward the sky as brick and mortar, stone and iron would permit. Without the vertical railway this would have been impracticable, in a business point of view. As it is, the best offices are those that are highest up. They enjoy light, air and ventilation, and they are reached without the least inconvenience by that revolutionary but now indispensable device, the vertical railway.

## CHAPTER X.

### THE LIGHTNING HARNESSSED—TRAMWAYS.

EVERYBODY is watching with keen curiosity the experiments that are being made with the new motor, electricity. It seems not only possible, but tolerably certain, that we shall not only harness the lightning to our street-cars, but make it run our lathes, sewing-machines, and other pieces of light machinery. It seems probable, too, that the discovery of so delicate and conveniently generated a motive-power will have the effect of stimulating the invention of aeronautical vehicles, and the mapping out of the great currents of the atmosphere. In short, it looks as though electricity were to be the supplanter of steam as a motor, at least for many kinds of work; as if it would soon be brought into the house, furnishing every man his own motive power in a convenient place, and helping on the cause of woman's independence by enabling thousands of sewing women to work in their own homes, while a little wire coming in at the window, and a small, softly-purring electric motor together furnish their light, their cheap telephone, their needed power, and perhaps their heat. Already in Europe and America have boats, velocipedes, ploughs, sewing-machines, lathes, saw-mills, elevators, printing presses, machine shops, pumps, hammers, electroplaters, rock borers, town water works, cranes, clothing-house cutting machines, dairies, ribbon-sawing and wire-weaving machines, etc., been operated by electric motors (see Du Moncel, "Electricity as a Motive

Power," and accounts of the experiments of M. Marcel Deprez, in the London "Electric Review," for April and May 1884), and inventors keep devising new applications and perfecting the old ones. It would not be at all surprising if people now living should see the day when trains of flying cars propelled by electricity, shall ply between New York and London, between London and Yokohama, and between Yokohama and New York *via* San Francisco, and when "air lines" in the strict sense of the word shall be established in ten thousand directions over the surface of every country on the globe. The first electric air ship has already mounted into the atmosphere. On October 8, 1883, Gaston Tissandier and his brother made an ascension from Paris in their electric car. The balloon was ellipsoidal in shape, the car made of stout pieces of bamboo lashed together and furnished with a propeller, rudder, batteries, etc. The aeronauts say that they proved the possibility of directing their course at will by means of their rudder, operated by electric power. (See illustrated article in "Science" for February 8 and 15, 1884.)

In the meantime, pending his more perfect installation as a navigator of the air, the proud genie of the clouds has been performing some very useful and humble labor upon a number of electrical railways in Europe and America. Professor Werner Siemens, of Berlin, will be known in the future as the father of the electric railway system, if there should ever be such a system; for his electric railways have not only been the first successful roads of the kind, but his experiments have fully proved their economic and dynamic practicability.

Professor C. G. Page, however, of Washington, District of Columbia, was the first to apply electricity to the rail-



road, having received from Congress an appropriation of twenty thousand dollars for his experiments. In 1860 he drew a car-load of passengers through the streets of Washington with an electric locomotive travelling at the rate of twenty miles an hour; the electricity was generated by zinc and carbon batteries carried in the engine. The places of the steam cylinders of the locomotive were occupied by helices. But the production of the motive power was found to be too expensive at that time, and the experiment was not repeated.

The next move was by Siemens and Halske, of Berlin. In the year 1879 they operated at the Berlin Exhibition a small electric railway, about five hundred metres in length. The seats of the passenger cars were arranged back to back, settee fashion. An auxiliary conductor of the electric fluid was placed between the rails, and the current, passing along this from the dynamo, was taken up by a metal brush on the car, and, after passing through the motor, returned by way of the rails to the dynamo again. The locomotive used was but a tiny affair. There were two or three more of these pleasure, or model, roads built in Germany during 1879 and 1880. The powerful current in the rails was somewhat dangerous. Once when a horse was crossing the track of the Berlin road he struck one of the rails with his iron shoe, and received a severe shock. The repairing of the rails also interrupted the current. To remedy this, Professor Siemens, afterward, at Paris and in other places, placed a metallic cable on each side of the track, and connected them with the moving train in such a way that whatever might be doing on the road, the electric circuit would always be maintained. For instance, in the case of the Charlottenburg and Spandau electric railroad, built in

1881, the conducting wires were elevated on posts beside the track; little trollys, or contact carriages, ran along the wires in the air, being themselves connected by wire with the motor in the car, and following where the car led the way.

The first electric railway for actual business traffic was constructed by Siemens and Halske in 1881, between Lichterfelde and the Military College, Berlin. The Siemens cars used here, and at the Paris Exhibition in the same year, are very different from those of the road of 1879, being in size and general resemblance quite like the ordinary European tram-car, each car having its own motor under the floor, and no locomotive being required. At the Paris Exhibition, just alluded to, the Siemens Electric railway extended from the Place de la Concorde to the interior of the Palais de l'Industrie. One day a great uproar was heard in the Palais, and it was soon discovered that the electric car had broken loose, and that the attendants were trying to stop it by throwing ties and other obstructions in its way. But over them all it went hopping and bouncing until it brought up in the ticket-office. As it struck the wall the conductor snapped, and a flash of lightning lit up the scene.

In 1882 Professor Siemens patented an electrical road-car, intended for use in places not rich enough to build a railway. The driver sits in front of this car and steers it by turning a wheel like that of a ship. The coach is stopped by simple pressure on a lever.

There are, in all, some seven or eight electric railroads in Europe at the date of this writing. That in use in the royal coal mines near Zanckerode, Saxony, hauls eighty tons of coal at a speed of about seven miles an hour; fancy a horse attempting to do as much! The Zanckerode loco-

motive receives its current from an overhead conductor. It is needless to say that for mines the electric motor is of peculiar value, being capable of service where the steam and smoke and noise of an ordinary locomotive would be intolerable.

One of the most recent of the electric railroads is that constructed by Messrs. Siemens, between Port Rush, the terminus of the Belfast and Northern Counties railroad, and Bush Mills, near the Giant's Causeway. It is six miles long; the power is taken from a neighboring waterfall by means of a simple turbine wheel, and the profits of the road come from visitors to the Causeway.

The experiments of Professor Siemens have been followed in America by similar but independent ones, on the part of Mr. Thomas A. Edison, the inventor. His first electric road was that from his laboratory at Menlo Park, New Jersey, to Plainfield, a distance of three miles, the farmers giving him right of way over their land. His first electrical locomotive resembled a large hand-car, and attained the speed of forty-two miles an hour. In February, 1882, an electrical passenger locomotive was built at the Edison Machine works in New York city. It is nine feet in height and fifteen feet long, and somewhat resembles, in appearance, the ordinary steam locomotive. There is, of course, no smoke-stack, the place ordinarily filled by that object being, in the electric engine, devoted to the head-light. This locomotive drew cars at a high rate of speed, at Menlo Park. The method of its working was, in general terms, as follows: the electricity was taken up from the track by the wheels of the locomotive, conveyed thence by metal brushes to conductors leading into the cab where the engineer stood and worked his levers. From the cab the

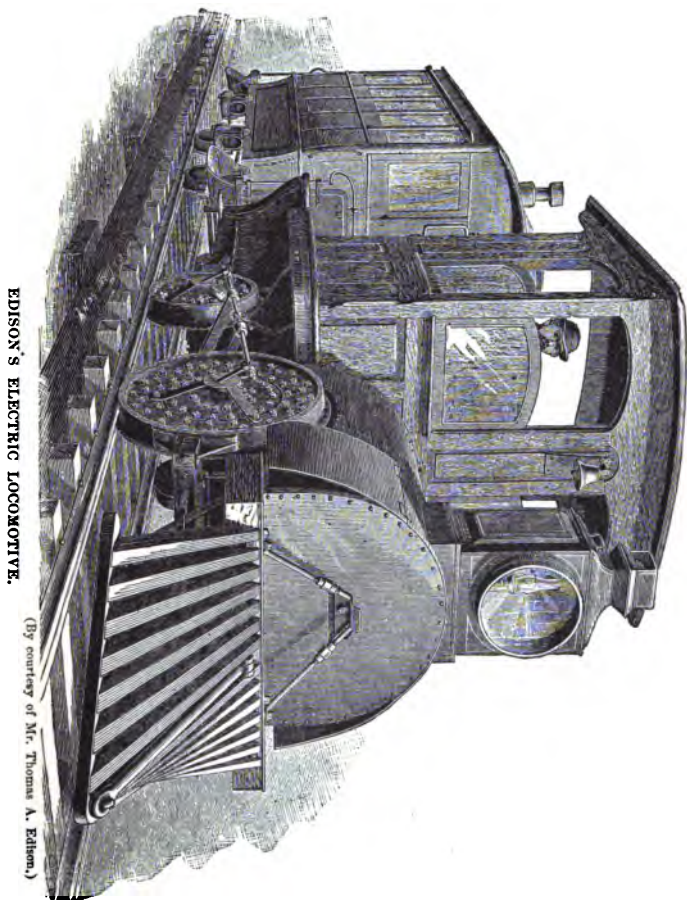

EDISON'S ELECTRIC LOCOMOTIVE.

(By courtesy of Mr. Thomas A. Edison.)

current returned to other magnetized brushes placed near and on either side of an armature in the forward part of the locomotive. *Now the armature was fixed on an axle,* and when the magnetized brushes on one side attracted it, it had to revolve in that direction; when the brushes on the other side attracted it, it reversed its movement, thus producing forward and backward motion of the wheels of the locomotive. The electricity was generated in the laboratory of Mr. Edison, and was fed to the track by wires. Edison in the fall of 1883 was operating an electrical railway, two and a half miles long, from a point on the Pennsylvania railroad to Metuchen. The locomotive can draw a passenger car containing forty people, at the rate of twenty-nine miles an hour. The freight train carries thirty tons, at the rate of eight miles an hour. Since the dynamo-electrical machine is an absorber as well as a developer of electricity, the plan of Edison contemplates the establishment of stations at intervals of ten miles, where dynamo-electrical machines may be placed, to communicate their stored-up energy to the rails, and thence to the apparatus in the locomotive.

The electrical railway at the Chicago Exposition has been referred to on page 75. The train on this road was moved at will, in either direction, and was perfectly under control. It carried, in all, twenty-six thousand eight hundred and five passengers. The auxiliary conductor was, in this case, laid in a trough between the rails (the patented invention of Edison and Fields).

Another of these electro-motive roads is now in operation at Greenville, New Jersey; it is one-eighth of a mile long. The experiments are under the direction of Mr. Leo Daft.

In the fall of 1883, a Daft electric locomotive, called the "Ampère," was in practical use on the Saratoga, Mt. McGregor and Lake George railroad—a line seven miles in length, extending from Saratoga up Mt. McGregor, at a gradient of ninety-three feet in a mile. This was the first utilization of an electric locomotive in the drawing of ordinary passenger coaches for practical and public purposes. The experiment was a complete success—the little engine moving off easily with its load of seventy passengers, amid the loud cheers of the crowd, whose scepticism as to the abilities of the motor was completely removed. The recently formed Massachusetts Electric Power Company has also successfully tried a Daft electric locomotive upon a railroad near Boston, and proposes to introduce the power on an extensive scale. In Mr. Daft's "low tension" system the danger to man and beast from contact with the electrified rails is entirely obviated. When the rails are charged with a current strong enough to move a whole train of cars, the ends of copper wires attached to the positive and negative rail can be placed against the tongue and scarcely a tremor is felt. The current in the rails of the Daft road, as in those of all other electric railroads, admits of cars passing in either direction, indifferently, over the same track. The Daft motors have attained a speed of seventy miles an hour, and have ascended grades of two thousand feet to the mile. As the author has elsewhere stated, one of the curious things discovered by Mr. Daft is that the electric current itself exerts a tractive or adhesive power, making the wheels bite the rails more firmly. But a more wonderful thing still is the way in which the adhesive power of the wheel is increased by electro-magnets. Placed beneath the car are one or more powerful magnets, which are not

ordinarily in use; but whenever the motoneer (or engineer) wishes to climb a steep grade, he turns a lever and switches off a part of his current into these extra magnets. They at once exert a tremendous pull downward upon the rail, and thus bind it and the wheels closely together, so that the adhesive power of a ten-ton electric locomotive is greater than that of a forty-ton steam locomotive, and most of the wear and tear is avoided.\*

Almost all the electric railways at present employ stationary steam-engines for supplying the mechanical power operating their dynamo-electric friction machines, or electric current generators. It is certain that the problem of thus converting the latent energy of coal into electricity has been successfully solved in an economic point of view (the economics of the railway, that is to say), for it has been shown, again and again, that the cost of burning coal under the boiler of a locomotive is one-third greater than burning it under the boiler of a stationary engine and converting it into an electric current. (See "The Electric Review," for February 28, 1884, and "The New York Tribune," for February 25, 1884.) So also in other industries, the saving in insurance rates, heat, dirt, noise, danger, loss of space, salary of licensed engineer, and cost of engines and boilers will be so great by the employment of electromotors, and the economy of distribution by wires from central stations so considerable, that it really looks as if the hour of doom had struck for steam, or, at any rate, that its uses will be more limited.

In London, several new electric railways are in process of construction. One of these is to extend under the Thames

\* See an account of the Daft experiments in "Harper's Weekly," for September 22, 1883.

THE DAFT ELECTRIC LOCOMOTIVE.

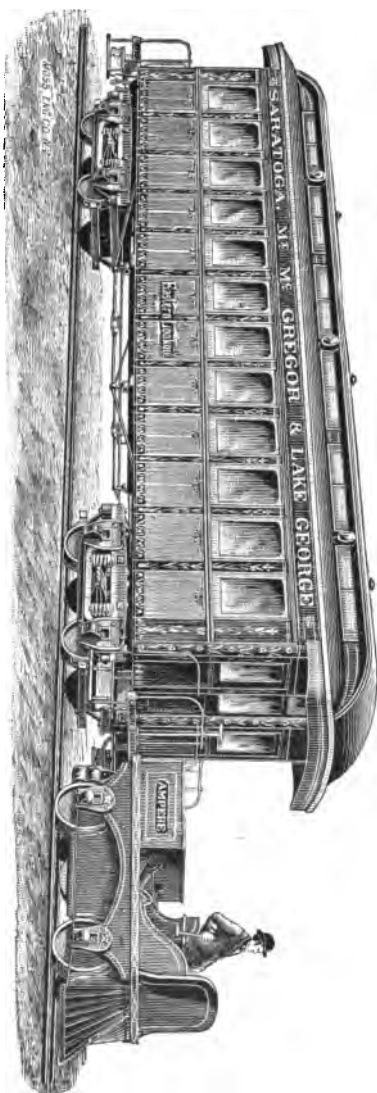



through a new tunnel. from Charing Cross station to Waterloo station. Messrs. Siemens Brothers are the contractors for this railway.

Various companies are being formed in the United States for the introduction of electric motors upon horse railroads and elevated railroads. A company has also been formed in Paris for the introduction of electro-motors on tramways. On September 6, 1883, an ordinary horse-car was propelled by the Faure-Sellon-Volckmar accumulators of the French company for a distance of thirty miles through the principal thoroughfares of Paris, and during the trial of six hours no accident occurred through the frightening of horses. Indeed, their freedom from noise, dust, and sparks, is one of the chief attractions of these novel motors. They are also recommended by their cheapness. For elevated city tramways they have the advantage of being free from smoke and cinders. If run upon longer railroads, the fact that each car contains its own motor would, perhaps, make the use of single passenger cars advisable, so that our trunk lines and local lines would resemble street-car roads; in such event, the results of collision, as has been suggested, would not be so disastrous as at present, and the wear and tear of rails would be less. "Travelling at the present time," says Lieutenant Bradley A. Fiske, "is a very luxurious thing. But what will it be when we can sit at an open window and glide along at the rate of sixty miles an hour, without the fear of smoke or cinders; when electric bells are at hand leading to the inaccessible retreats where porters now secrete themselves safe from discovery; when we can start from our homes to take a car for Boston, as we now start to take an elevated train, knowing that if we miss one car, another will soon be at hand; when electric incandescent lamps, which cannot, in

case of accident, scatter burning oil in all directions, shall fill the car with a mild and steady light; when despatches can be received on board a train in motion as well as at an office; when the cars shall be heated and meals prepared by electric stoves, which cannot, in case of accident, set fire to the car — all the electricity needed for these and numberless other purposes being derived from the same convenient source — the conductor carrying the current which furnishes the propelling power?"\*

From electrical tramways for cities, we may pass to a consideration of other kinds of city passenger railways.† The



(By courtesy of Mr. John Stephenson, New York.)

THE FIRST STREET CAR IN THE WORLD.

first street railway in the world was the New York and Harlem, incorporated 1831. The first cars were run in Novem-

\* "Popular Science Monthly," April, 1884.

† The authorities that have been consulted for this, the first full, account of the origin of city street railways, are D. K. Clark's work on "Tramways," London, Crosby, Lockwood and Company, 1878, and supplementary volume to same, 1882; F. Sérafon's "Étude sur les Chemins de Fer," etc., Paris, Dunod, 1872; Martha Lamb's "History of New York," II, 721; London "Times," August 31, 1860; "First Street Railway Banquet in the Old World," by George Francis Train, Liverpool, Lee, Nightingale and Company, 1860; W. H. Brown's "History of the First Locomotives in America"; and various miscellaneous journals, old guide books, and old gentlemen.

ber, 1832, from Prince street to Harlem Bridge. These cars were curious structures, from the point of view of people of this generation — being very much like the stage coaches of the time, each having three compartments with side doors; there were leather springs, and the driver sat on an elevated seat in front, and moved the brake with his foot. The car represented in the cut was one of the first two that were built for the Harlem line, and was made by John Stephenson. The opening of the road, says W. H. Brown, excited a good deal of interest, and the streets along the route were crowded with curious spectators. The bright new car, the "John Mason," led the way, and the ribbons were handled in gallant style by a well known knight of the whip, named Lank O'Dell, who always drove a pair of gray horses. Both the cars that figured on the occasion contained city officials (the mayor and members of the city council) and invited guests. It was thought by many that there would be great difficulty in stopping the cars quickly enough to avoid accidents to street vehicles. But the vice-president of the road, being very desirous of convincing people how ungrounded were their fears in this regard, determined to give them ocular proof of the ease with which the cars could be brought to a dead stop. So on the trial day, he posted himself with a number of witnesses somewhere about the corner of the Bowery and Bond street, having previously ordered the drivers of the two cars to watch for his signal, and then stop the cars with all the haste they could. Now, when O'Dell came dashing along, and saw the signal, he easily brought up the car, since he had previously had some experience in hauling materials for the road; but the hackman who drove the second car, forgetting the lever of the brake, only drew hard on his

lines and shouted, "Whoa!" But in vain; his car slid inexorably forward, and the tongue went crashing through the rear end of the "John Mason," causing the dignified inmates to beat an unceremonious retreat, amid the laughter of the bystanders. No one was hurt, however, and soon the triumphal train moved on to Harlem Bridge. This is the first street-car collision on record, and it occasioned a good deal of merriment among the citizens, and considerable annoyance to the vice-president; since for several days afterward, the roguishly inclined among his friends would imitate his attitude and gesture on that unlucky street-corner, and raise their arms for him to stop, as he had done to the car-drivers. The fares were paid in silver sixpences of the old Spanish currency then in circulation. In 1837 the road temporarily succumbed to steam cars, but resumed work in 1845. The old Harlem Railroad Corporation still owns the right of way through the Bowery and Fourth avenue, and receives a large income from the street railroad, as well as from the Hudson River and the New Haven railroads, in return for a cession to them of right of way.

The early street railways of New York were not very popular at first, and were for a time disused. Much of their unpopularity was doubtless due to the objectionable nature of the rail employed; it projected too much above the surface, and was injurious to street vehicles. The first rails were made with grooves, or iron gutters, to guide the wheels. The low step-rail, now everywhere in vogue, was invented and first used in Philadelphia in 1855. In New York the street railway was revived about 1852, by M. Loûbat, a French engineer, who constructed the Sixth Avenue railway in that year. At nearly the same date the Second, Third, and Eighth avenue lines received their

charters. In 1853 the Cambridge (Massachusetts) horse railroad was chartered, and the Metropolitan of Boston at about the same time (Charles L. Light, engineer). The first car was run out of Boston on the Cambridge road, in April, 1856. By the year 1858 horse railroads were in use in all the large cities of the United States.

When M. Loûbat returned to Paris in 1853, he at once introduced the new American street car to his fellow Parisians, laying a line along the Avenue de la Reine. The French at first called the new roads *chemins de fer Américains*, or, for short, *l'Américain*; now they call them "tramways."

In 1860 that eccentric character, George Francis Train, introduced the American street-car into England, the first line opened by him being in Birkenhead, opposite Liverpool. The cars were built by the Stephenson firm in America. The line ran from Woodside Ferry to the entrance of Birkenhead Park, a distance of one mile and a quarter. The cars seated twenty-four passengers inside, and the same number on the railed-in top. In his curious pamphlet on the celebration of the opening of the road (August 30, 1860), Mr. Train gives an illustration of one of the cars, by which you perceive that there were queer-looking conical brooms hanging downward in front of each wheel, to sweep obstructions from the track. Mr. Train gave a grand *déjeuner* on the opening day; the invitation cards were exquisitely lithographed in gold and colors, and *were sent by him to all the crowned heads of Europe, and to all the eminent people of Great Britain!* In 1861 Mr. Train opened a street-car railway in Bayswater, London, after encountering very determined opposition. It was argued by the London city officials that the rails would tear off the wheels

of vehicles, and that it would be impossible to repair the streets without interrupting traffic on the tramways. But the street-car is now very popular in England, as it is also in nearly all other countries of the world. There are street-cars, *e.g.*, in Moscow, Leipzig, Naples, Oporto, New Zealand, Bombay, Java, Australia, India, Japan, the Cape of Good Hope, Chili, Peru and Buenos Ayres. The last-named city had, in 1872, seventy miles of street railways. It was at one time the custom in Buenos Ayres for trumpeters to ride in advance of the street-cars in order to warn off other vehicles and prevent collisions. Sydney, in Australia, has forty miles of street-car tracks, and the motive power is steam. Steam and compressed air are used as street-car motors in several cities in the world; but they have not yet come into general use, owing chiefly to the difficulty of keeping the low rails used in crowded thoroughfares clear of ice and snow and the greasy slush of the street; for a locomotive wheel only spins around on a slippery track.\* The best street locomotives are made by Merryweather, in England. As is well known, there are several railways in Chicago and San Francisco which are operated by continuous cables and stationary steam engines. The cables are some eight inches underground, and when it is desired to propel a car the conductor lets down through a narrow continuous slot a kind of "grip" that seizes fast on the moving cable, and the car is drawn along at a uniform rate of speed. The cable railroad on the New York and Brooklyn bridge is a novel affair, exciting as much of curiosity as the vast Karnak bridge

\* Mr. Daft's device of the electro-magnets alluded to in this chapter would seem to offer the very means needed for keeping the wheels firmly to a track charged with his low-tension current. The current of one hundred and fifty volts is perfectly harmless to man and beast; a tension of from three hundred to twenty-two thousand volts is dangerous, but that of one hundred and fifty only causes a pleasant tingling in the nerves.

itself does of wonder. The continuous cable runs in the form of an oval, travelling rapidly over large pulleys. The grip used is what is called a rolling-grip (the invention of Colonel William H. Paine) and consists of four horizontally-placed grooved wheels and other mechanism, all located under the centre of the car. When the brakeman turns his brake-wheel, the grip wheels under the car begin to revolve in the same direction that the cable moves, and at the same time they begin to hug the cable tight enough to draw along the car. When the revolutions of the car-wheels proper reach a speed equal to that of the moving cable the grip-wheels no longer revolve, but are fastened tight to the cable by the brakeman's wheel-and-lever apparatus, thus drawing the car up the incline of the bridge. By a system of switches at each end of the bridge, the cars are kept moving round, passing over on one side, and then (switching and reversing the direction) back on the other side. At the date of this writing a double cable road is constructing in New York city, from One Hundred and Twenty-Fifth to One Hundred and Eighty-Seventh streets, a distance of about three and a half miles along the Hudson River, beyond Central Park.

When rapid transit is desired in great cities, only two methods of attaining it are possible: you must either have a railroad underground, or a railroad in the air. New York has found the elevated railroad successful, and at the present time the four double-track lines of the Manhattan Elevated Railroad Company serve for the passage of three thousand five hundred trains a day, and the transportation of eighty-six million passengers in a year—some three hundred thousand a day.

In London high brick viaducts are used by some of the

trunk-lines entering the city. The London and Greenwich Company's viaduct is fifty-three miles long, has one thousand arches, and cost one million three hundred thousand dollars per mile; it has not proved a paying investment. The viaduct plan has recently been tried in America by the Pennsylvania railroad, which has constructed a brick viaduct of considerable length, to enable cars to penetrate to its grand new terminal station in the heart of Philadelphia.\*

The New York elevated roads are designed only for passengers, and the light trains therefore run with complete safety upon the branched iron pillars that support the track. Up to 1882 not a single passenger had been injured through the fault of the elevated railroad company. The origin of the road was in 1866. In 1867 the Legislature of New York accepted the plans of Charles T. Harvey out of over forty others that were presented to it. The inventor was allowed to erect an illustrative section of his road from the Battery through Greenwich street to Twenty-Ninth street, and if the road proved satisfactory to the Governor and his commission, the inventor was to be allowed to extend it to Harlem River; if it did not prove so, it must come down, and to cover damages that might result to property, Harvey was obliged to file a penal bond of one million dollars with the city comptroller. The road was built, however, upon these severe terms. The first motive power consisted of endless wire ropes worked by stationary engines. But in 1870 the company failed, and was supplanted by the New York Elevated Railroad Company, which put small locomotives on the tracks, and by energetic administration

\* For a description of some early elevated roads compare Chapter III, page 32, and Chapter VII, pages 115, 116.



established the success of the undertaking. Most of the original road is now merged in the roads of the Manhattan Company.

Nearly everybody disliked the overhead railways at first. But the disagreeable impressions produced are soon lessened by familiarity, and the roads have come to be regarded as a necessary evil, even by most of their worst enemies. The key of popular opinion is struck in the following playful words of a writer in the "American Architect" (1883); he has been exhausting the vocabulary of his scorn and dislike upon the elevated roads for their damaging effect upon certain noble architecture in their neighborhood, yet concludes his remarks thus: "But let us shake off the general dustiness we have gathered by the walk along the substructure of the road, forget the holes burned in our coats by hot cinders, overlook the few grease-splashes upon our summer hat, and forgive the brakeman who found amusement in squirting tobacco juice down upon us, and let us go up and follow the unthinking populace in encouraging the monopoly. Oh, how delightful! Bless me, here we are at old Trinity again! I take it all back; let architecture and property rights and personal privileges and past associations perish, so long as we can so fly through the air without following suit."

NOTE. — Probably the most richly humorous bit of elevated railway literature in existence is to be found in the "Report of the Select Committee of the House of Representatives of Massachusetts on a Rail Way from Boston to Albany, 1827." There is such a provincial and rural smack about this whole report, such naïve ignorance, and such a school-boy style of composition, as to render it immortally funny to all railroad men and inventors. Among the pieces of knowledge graciously imparted by "your committee" to the members of the Legislature is a description of "a single Rail

Way," invented by Colonel Henry Sargent, of Boston. His single rail track, according to the Report, was to be elevated upon posts about three feet above the common road. "Sidelings" were to be made at suitable intervals. "The rims of the wheel are to be made concave to keep them upon the rail. The carriage has two bodies, one on each side of the rail, and extending down with iron braces from the wheels. The balance and weight are below the Rail." So far, so good; we have here a road bearing a general resemblance to the elevated railways of Mr. Meigs and General Le Roy Stone (compare Chapter VII, "Bicycle Railways"). But study carefully what is said about the "sidelings": "Your committee" offer the following objections to the adoption by the State of Colonel Sargent's invention: His railway "would incommode the passing and repassing travel. Each carriage must stop, and one or both the drivers must alight, and open, or swing, a portion of the Rail from the direct line to the sideling, and then return it again, like a gate, to its place. In returning, the same process must be repeated. If two lines should be constructed, the one for the going and the other for the returning travel, still the same inconvenience would occur where one carriage was to move faster than another. They must both stop till one passed the other in the manner before mentioned. A single Rail Way, by being elevated several feet, would incommode the country like a fence passing through the villages, and like a gate or bar across every road that it passed. And if the movable portion of the rail were left partly open at any time, as might often be the case, the carriage would be very likely to run off, an accident which in many cases might be serious; besides the great difficulty there would always be in replacing a loaded carriage upon an elevated Rail."

## CHAPTER XI.

### THE FUNCTIONS OF THE RAILWAY IN WAR.

THE functions of the railway in time of war are peculiar and delicate, and are deserving of deeper study on the part of statisticians and military men than they have yet received. The through railway lines of a country, with their telegraphic wires, may be regarded as so many trunk-nerves, overlapping — with their diverging branches — the dividing lines of the different states, and forming a medium of communication of the greatest efficiency in time of harmonious coöperation. Railroads both bind and sever. They strengthen a democracy like that of the United States by the thorough and rapid interchange of ideas they effect between distant and differing populations, and at the same time they lessen the danger of Cæsarian concentration of armed soldiers on distant points, owing to the ease with which they can be rendered useless,\* but for the same reason they afford a tempting opportunity for the almost instant paralysis of the business of the country, in case of an uprising of the disaffected or baser elements of society. This last danger is a grave one. Witness the ominous railroad riots of 1877.†

\* Compare the causeways of ancient Mexico, and the ease with which the army of Cortez was well-nigh annihilated by the cutting of these, and by the destruction of the bridges connecting their different parts.

† The great railroad strikes and riots of 1877 lasted from the middle of July to the first of August, and spread over fourteen States, in all of which there was more or less serious stoppage of business and destruction of property by armed rioters. United States Regulars and State Militia united their forces in the suppression of what threatened to be a communistic reign of terror, but not

In formal war, too, railroads form a very precarious reliance when they are within reach of the enemy. In July, 1870, a few Prussian lancers crossed into French territory and blew up a viaduct of the railway by which communication between the different portions of the French army was kept up; and, as a consequence, MacMahon did not receive at Wörth the support he had expected, and was thereby seriously crippled. So the defeat of Bull Run was due to a brigade of soldiers brought to the scene of action from the Shenandoah Valley by the Manassas railroad. Colonel Hamley, in his work on "The Operations of War," says that an invader should always direct his attack on a part of the enemy's country where there are few railways, since their effect is, on the whole, in favor of the defender. A flank movement by rail is especially dangerous, if the enemy can reach the road, since he can seriously cripple even a large force by attacking small sections of it at once while it is *en route*.

On the other hand, supply railways are of inestimable value to an invading force, enabling it to be kept in close communication with provisions and munitions of war, however far away it may be from the points where these are stored. Formerly, it was necessary for an army to remain stationary for a time while depots of fresh supplies were being formed in the rear. But now the railway keeps even step with the army in its march, and, if not liable to interruption by the enemy, furnishes ample supplies for the daily

before serious damage had been done, the Pennsylvania railroad alone losing about five million dollars by the riots at Pittsburgh. The four great trunk lines from the Atlantic seaboard to the West were for several days in the power of the strikers, and scenes of violence were enacted in many of the Western States, this side of the Mississippi River. (See Allan Pinkerton's "Strikes, Communists, Tramps, and Detectives," New York, Carleton, 1878; J. A. Dacus's "Annals of the Great Strikes in the United States," Chicago, Palmer, 1877; and "History of the Railroad Riots of 1877," by James D. McCabe, *alias* Edward W. Martin, Philadelphia, National Publishing Company, 1877.)

use of the largest bodies of soldiers. It has been calculated that one day's supply for an army of eighty-five thousand men can be conveyed four hundred miles by one railway train in forty hours, and the same amount of supplies conveyed by the common roads would require five hundred draught horses, and from twenty-five to thirty days' time.

During the Georgia campaign, General Sherman was linked to his base of supplies by a single line of railroad, and it so supplied his great army of one hundred thousand men that not a soldier was for a single day without suitable clothing and ammunition, and neither man nor beast ever lacked food for twenty-four hours at a time.

In 1870, when the Germans were besieging Paris, a single railway fed the whole army of two hundred thousand men, and also brought up the siege materials and reinforcements at the rate of two or three thousand a day. In the Italian war of 1859, the *strade ferrate* proved of great value to the French. On one occasion French troops arrived by train from Genoa, just in time to turn the scale of battle and secure the victory for their army. It seems odd to think of a general ordering a special train in order that he may be in time for an engagement, but such things have happened.

The facilities for the rapid mobilization and concentration of troops have been increased six-fold by this magnificent instrument, the railway. "Victory is in the legs of soldiers," said Napoleon. How fortunate it was that the great Corsican had ended his career before the introduction of railways; for, with such a beautiful toy in his hands, his splendid strategic genius would perhaps have enabled him to enslave all Europe, for a time, at least. Think how field-railways would have changed the relations of armies at

Waterloo. But Napoleon and Wellington were no better off than Rameses II in the matter of transportation of troops. In these times, the railway and the telegraph have made of a great battle a still more scientific game of chess than it was in the days of the European generals just named.

Railroads not only save the long and terrible marches which kill more men than die on the field of battle, but they also lessen the expense of a war by hastening its issue. They permit of the rapid disposal of large bodies of prisoners, and, above all, they admit of the rapid removal of the wounded to clean and roomy quarters. Napoleon said that he preferred a dead soldier to a wounded one. The wounded are an encumbrance to an army, both during and after an engagement, and the superior comforts to be attained at a distance from the jar and clash of war, make the function of the railway, in this respect, a blessed one. During the Franco-Prussian war, very few German soldiers died from wounds received; for they were removed at once to cheerful hospitals in the interior of Germany, where the feeling that they were at home, and the home-nursing, wrought wonders for them in a short time. The hospital cars that carried them from the battle-field contained straw mattresses resting on boards and springs; there was an attendant in each car, and attached to each train were a cook, a surgeon or two, an apothecary with his medicine chest, and an officer in charge of the whole train. During our own civil war, the Sanitary Commission carried two hundred and twenty-five thousand wounded men to the rear in hospital cars. During the Tennessee campaigns, the Commission bought a train of cars of its own. Its "railway ambulances" were fitted up with elastic beds, and all the appliances of a regular hospital. The steamboats of

the Tennessee and Cumberland Rivers were also used for the same purpose.

The Germans are far in advance of other nations in the scientific study of the functions and possibilities of the railway in war. Previous to the struggle of 1870-71, their soldiers had been trained to embark and disembark from the cars with rapidity and precision. There was, and still is, a railway section of the general staff, the duty of which in time of war, is to acquire a precise knowledge of all the railroads of the hostile country, and of the best means of crippling or gaining possession of them. In time of peace, it is the duty of the railway staff to study the railways of Germany, and of foreign countries with whom she may at some future time be at war. In 1870 the consequence of this system was, that at the end of four days after the order for the mobilization of the troops, the most minute arrangements, down to the hour and minute, for the departure of trains and troops had been made, and forty trains a day began the transportation of troops and supplies to the frontier, where, in the course of a fortnight, every portion of the vast army, down to the grave-diggers, had arrived and was in its place.

Then, by means of the railways, each corps of the German army was connected with and fed by its own local district, thus rendering all Germany the source of supply for the troops. In strong contrast with this system was the state of the French army. In France all was confusion. Their supplies were stored up in magazines, and the most contradictory orders were received in regard to the disposition of them. Their railways were the scene of obstruction and confused and aimless movements, while those of Germany "were acting with the unity and certainty of full

rivers flowing onward to the sea."\* A good instance of the value to the German army of its railway corps is noted by historians of the Franco-Prussian war. When the garrison of the fortress of Metz interrupted railway traffic on the line from Saarbruck through Pont-a-Mousson to Paris, and by Nancy to Strasbourg, General Von Moltke directed a railroad twenty-five miles long to be built, uniting the Metz and Saarbruck and the Metz and Paris lines. Three thousand miners working night and day, amid the roar of cannon, built the road in half a week or less, and the railway communication of the German army was reestablished.

Since the Franco-Prussian war the Germans have been paying more attention than ever before to the discipline of their army in railway tactics. They have recently added a railway regiment to their permanent army organization. It is the duty of this regiment both to construct railways and destroy them, and to engage in practical railway service. The government has appropriated a railroad forty miles in length for the purpose of practising the men, although the road also carries freight and passengers like any ordinary road. The sergeants serve as conductors, and the privates as brakemen, engineers and firemen. Those not serving on the train are kept at work laying track, tearing it up, and in every way learning both how to utilize railroads and how to render them unfit for use to others.†

\*The author has noted that, as early as 1866, M. Louis Grégori, in a paper published in the "Revue des Deux Mondes," had suggested at length to the French people the formation of a military railway organization. Well would it have been for poor France if she had but listened to her counsellor!

†For more detailed and technical information concerning the influence of railways in modifying the movements and status of armies, the following works may be consulted: "Der Krieg im Jahre 1870," von M. Annenkoff, Berlin, 1871; "Das Train-communications und Verpflegswesen vom operativen Standpunkte," von H. Obauer und E. R. Von Gutenberg, Wien, 1871; "La deuxième Armée



To recur to our own civil war. Although neither the Confederate nor the Union troops had been previously drilled in railway manipulation and tactics, yet their generals soon discovered the great strategic importance of the iron roads, and the necessity for railway corps in the armies. Many of the most exciting episodes of the war arose from the attempt of one side or the other to control important lines of railway. The chief object of General Sherman in his march to the sea was to cut and destroy the railroads in the enemy's country, and thus prevent the rapid transference of the seat of war from Richmond to a point further south. He accomplished his object, and the long lines of ash-heaps, charred wrecks of bridges, and twisted ties he left behind, played an important part in the series of movements that struck the death-blow to the confederacy. The South had no time for forging iron rails, even if she had had the shops and tools; and during the latter days of the contest the rails on southern roads had become terribly used up from long service. Those twisted by Sherman's men could not be repaired except by special machinery; the loss to the South was irreparable.

During the Atlanta campaign of Sherman, says Jacob D. Cox, the railroad repairs of the army were under the management of a construction corps of two thousand men, and there was also a large railroad transportation department. Their work was of the highest importance; the interchangeable timbers of wooden truss bridges were always kept prepared in the rear, and when a bridge was burned by the enemy it was restored as if by magic. At Chattahoochee and other places great trestle-work bridges

hundreds of feet long and nearly a hundred feet high were woven together with the rapidity with which an ordinary pioneer corps bridges a petty ravine. Nothing disheartened the Confederates more in this campaign than to hear the whistle of the locomotive in the rear of the Union troops, within a few hours after they had heard that the railways had been broken so as to cause the Yankees great delay and annoyance.

The story of that thrilling episode of the war, the "Capture of a Locomotive," has several times been told.\* Twenty-two picked young men in the army of General O. M. Mitchell band themselves together in romantic secrecy for a desperate and daring adventure, which is no less a feat than proceeding in disguise within the enemy's lines, seizing a locomotive and car, and then, in rapid flight toward Chattanooga and their own lines, burning behind them the bridges of the railroad, and so crippling the hostile force that General Mitchell shall be enabled to seize both Chattanooga and Atlanta, and thus hold the key to east Tennessee. The chosen band separate to meet at a certain rendezvous on the railroad; they all arrive but two; enter a train loaded with Confederate troops and ammunition; and when they reach Marietta, and the engineer, fireman and other employés of the train have all entered a restaurant for dinner, boldly walk forward, climb into the baggage-car and engine, which they have quietly uncoupled from the rest of the train, and before anybody knows what has happened are thundering away along the track. The astonished conductor pursues in a hand-car, reaches the next station, boards a passenger train, and is after them with a volunteer force. And then

\* For instance, in "Harper's Monthly," and in the book of Rev. Wm. Pittenger, published by the Lippincotts.

begins one of the most exciting chases on record. Two of the Union men are accomplished engineers; the remainder are concealed in the baggage-car. The engineer and his fireman give out at every station that they are carrying powder in a special train to Beauregard's army; they cut the telegraph wires as they go, and tear up the track at intervals; successfully pass a train coming in the opposite direction, but not before waiting a fatal half hour and more for it; from time to time see the pursuing train close behind them, and try in vain to stop it by dropping ties on the track and tearing up rails; the men in the baggage-car chopping up the sides of their car for fuel; and after a wild, mad race of one hundred miles being obliged at last to take to the woods owing to the fuel and water of the engine having given out. It happened that there was a regimental muster near the place where they abandoned their locomotive, and the planters were present with their bloodhounds and horses. The fugitives were therefore all captured and thrust into a foul negro prison. Andrews, the leader, was hung at once; seven more soon followed him. And the order came for the execution of the rest. But they gagged their jailer, overpowered the guard, and escaped by miraculous good fortune—two to a United States gunboat on the Gulf, and others to the Union lines. Six were, however, recaptured, and were afterward exchanged. When they arrived at Washington they were given a reception by President Lincoln, received each a medal, had their money arrearages made up to them, besides receiving each a purse of a hundred dollars and a furlough for the purpose of visiting their friends. In significant contrast with this treatment was that received by the brave and energetic conductor, Fuller, who pursued the dare-devils who had run

ARMORED RAILWAY TRAIN.

(By permission of the "Scientific American.")

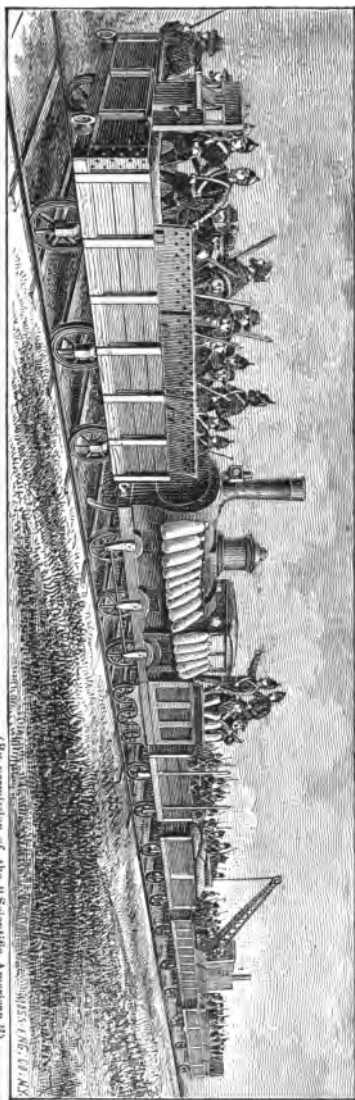

away with his locomotive, and handsomely captured them all to a man. For this service he got a vote of thanks from the Georgia Legislature, and the promise of a medal, which he never received!

There is doubtless many another as thrilling adventure as this that might be told of the days of the war. And there are probably many new functions of the railway as a military agent still to be thought of and set in operation. One of the most curious uses to which a railway train has been put in war was that devised by the English in their Egyptian campaign of 1882. They fitted up an Armored Railway Train as a kind of moving fort. It was operated on the railway near Alexandria. Six car-trucks containing soldiers were furnished with iron shields at the sides; the locomotive had a car preceding it, and had its sides protected with rows of sand-bags. One of the cars carried a crane; a Nordenfeldt gun looked over the bows, and three Gatlings projected from the rear of the train, which carried, in addition to what has been mentioned, mines, electric apparatus, and appliances for laying down and destroying tracks.

## CHAPTER XII.

### THE LUXURIES OF TRAVEL.

IF that querulous old Bostonian, Mr. Breck, whose complaints about the unseemly mingling of castes in the railway coaches of his day have been quoted on a previous page in this volume, were living at this time, he would have no need to harp on that particular theme any longer. His aristocratic tastes would be abundantly gratified by the first-class cars of nearly every country into which he would be apt to travel. The Russian saloon-cars have already been described (page 101). The ordinary Wagner and Pullman coaches of America, with their luxurious appointments, are too well known to the readers of this day to need description. But how Mr. Breck would have pitied the mental state of the man who should have told him that in fifty years from the time when he wrote his little Jeremiad, people would travel on steam trains containing a smoking car, parlor-dining-room-and-sleeping car, kitchen, wine-cellar and bathing-rooms.\*

The height of luxury in travel has been reached by royalty in Europe and nabobism in America. Contrast the travelling coach of Napoleon I with the railway train of his imperial nephew.

Bonaparte's carriage (used by him in the Russian campaign of 1815) was captured by the English at Waterloo,

\*On some few railway lines in the United States, bathing-cars have been introduced, containing alcoves furnished with bath-tubs and other suitable appurtenances.

and now suffers the ignominious fate of being placed on exhibition in Madame Tussaud's wax-work show in London. The coach is a model of compactness. The bedstead is of polished steel, and there is a projection in front made to receive the feet of the occupant when he was reclining. Over the front windows is a roller-blind, which, when pulled out, admitted air and excluded rain. The secrétaire was fitted up for Napoleon by Marie Louise with nearly one hundred articles, including a magnificent breakfast service of gold, a gold wash-basin, spirit lamp, perfumes, etc. In a recess at the bottom of the toilet-box were two thousand gold napoleons; on the top of this box were the imperial wardrobe, a writing desk, maps, telescopes, arms, a liquor case, and a large silver chronometer, by which the watches of the army were regulated. Thus cramped and cabined, did the great Emperor jolt along over the execrable roads of eastern Europe. Now for the nephew.

In August, 1867, the Emperor Napoleon III, with the Empress Eugénie, paid a visit to the Emperor and Empress of Austria. Their suite of travelling apartments consisted of nine railway coaches, communicating with each other by tastefully decorated bridges. In the middle was a handsome sitting-room, furnished with chairs, ottomans, pictures, clocks, and chandeliers. On one side of this room was the dining-room, and on the other the Emperor's study. In the middle of the dining-room was an extension table with easy chairs ranged parallel to the sides of the car. The Emperor's study contained an elegant writing table, a clock, in the style of the Renaissance, a thermometer, barometer, and telegraphic apparatus, by means of which communication was established with the several apartments of the various court officials travelling with the royal pair. Next to the

study was the bed-room of the Emperor and Empress, with dressing-rooms attached. In the remaining cars were the apartments of the imperial suite, the kitchen, wine-cellar, and a conservatory filled with the choicest flowers. And all this, Monsieur Bonaparte, flying forward at forty miles an hour, with no jolting, no broken axles, and no mud!

Let us also see how Queen Victoria travels. Her journeying is slightly different from that of the Queen of Sheba to Jerusalem. When the Queen of England travels from Windsor to Balmoral, she traverses the length of England in a single night, reposing in a royal car. The utmost precautions are taken for her safety, and detailed instructions are issued to the various railway officials for that purpose; none of the public are admitted, under any circumstances, to the stations between Banbury and Edinburgh; the railway servants perform the necessary work on the platforms as noiselessly as possible; and no cheering is permitted to disturb the repose of the Queen; the royal train is preceded by a pilot engine, and is furnished with continuous brakes and electric communicators; and, finally, a lookout man is stationed on the tender of the engine with orders to keep a sharp eye upon the rear of the train for signals in that direction, and similar orders are given to the guard in the front car.

In America, too, we have some royal travellers. When Senator Sharon, of Nevada ("the silver satrap of the Sierras"), wishes to go from his home to Washington or New York, he orders his wagon to be brought out of the barn and hitched up for his little drive over the continent. The wagon is a private palace car, finished inside with rare native woods, pier-mirrors, hanging book-shelves, evening card-table and luxurious sofas, while costly crystal, and delicate china and silver ware crown the oak buffet. When



the senator reaches Washington, he stores his car until he wishes to return.

The elegant private car of President Vanderbilt is fitted up with a state-room, sitting and dining-room, card-room, observatory, kitchen, electric bells, and the richest furniture of every kind. When he travels, he has a special engine, and a special time-table, and all other trains must keep out of his way. He often traverses a hundred miles in a hundred minutes; the mere conception of such speed almost takes away one's breath.

Mr. Vanderbilt's car cost twenty thousand dollars; as did also a beautiful car presented to Mr. E. H. Talbott, the editor of the "Railway Age," in Chicago, by various manufacturing firms of the country, in token of admiration for his energetic administration of the Chicago Exhibition of Railway Appliances. It is needless to say that there is nothing of the nabob about Mr. Talbott. His car is simply designed to exhibit a model railway coach. It is a perfect beauty from wheel to deck-lights. The parlor is finished in solid mahogany. The larger pieces of the silver service are engraved with representations of old historical locomotives and cars. In a mahogany case are working models of the Westinghouse brakes, so arranged as to show every movement of the engineer in handling them, and being, in addition, actually connected with brakes of the whole train, so that an occupant of the car can stop it at pleasure. There are also an observation-room, bed-rooms, kitchen and pantry. The chief rooms are finished with the richest woods, native and foreign, in their natural colors, and furnished with mirrors, carpets and upholstery in keeping with the other features of the carriage.

Let us now look at a bit of the history pertaining to the

invention of these luxurious travelling hotels. The first sleeping-car ever built in the United States was made in the shops of the Terre Haute, Alton and St. Louis railroad, by a mechanic named Woodruff. The coach provided seats



(By courtesy of the "Railway Age.")

INTERIOR OF THE "RAILWAY AGE" CAR.

for sixty passengers, and at night the said seats were converted into flat berths. The inventor was too poor to pay the patent fees. So the president of the road drew up the initial papers, and advanced him the money by which the

patent was secured (1856 or 1857). Colonel Childs, engineer of the railroad, took a half interest in the patent for a merely nominal sum. But after the patent had been secured there was no one in Terre Haute interested enough in the invention to advance funds for having it introduced into use. The officers of the road laid the subject before the superintendent of the New York Central railroad, who allowed a couple of cars to be fitted up as sleepers and run upon the western division of the Central. It is tolerably certain that Webster Wagner saw the novel cars, or heard of them, and thereupon set to work at the invention of his own sleeping-cars, for in 1858 he built for the New York Central four sleeping-coaches, which he patented. Woodruff disputed his patent in the courts; his (Woodruff's) prior claim was admitted, and he consequently received a handsome royalty from both the Wagner and the Pullman companies, and died worth several hundred thousand dollars. Wagner built his first palace-car in 1867. He was of German descent, was born in Palatine, New York, was apprenticed to his elder brother to learn the wagon-maker's trade, and later became connected with the railroad in some subordinate capacity, where he was led to apply his mechanical knowledge to the invention of the most sumptuous *wagon* in the world. He was elected to the state legislature after he had become rich and well known, and was killed in one of his own coaches, by the railway accident at Spuyten Duyvil, January 13, 1882. Senator Wagner was tall, with a slight stoop in his broad shoulders; his eyes were blue, and hair and beard gray at the time of his death.

George M. Pullman, founder of the car company and the model town in Illinois that bear his name (the town is ten miles south of Chicago), was once a miner in Colorado, and

is said to have been so poor that, like both Woodruff and Wagner, it was with difficulty that he could raise money enough to introduce his invention of a day coach transformed into a sleeper. His first car was run in 1859. Some of the early Pullman cars had sixteen wheels instead of twelve, the present number.

The latest luxury for travellers is the Mann "boudoir" car—divided into eight cosy little rooms, some for two and others for four persons each. The boudoirs are all on one side of the car, an aisle running along the other side. There is a smoking room, and there are electric bells, etc. In short, one can travel in these cars in complete privacy, as if he were in his own coach. The cars were first run between Boston and New York.

*Smoking-cars* may be counted among the luxuries of the rail; luxuries for men in the positive sense, and for women in the negative sense. It is rather an embarrassing case for the conductor when he discovers a woman smoking a pipe in a railroad car. At one of the railway stations between Cologne and Berlin, a few years ago, a lady was being shown into a ladies' car by the porter of the station, when, to their dismay, they beheld two recumbent dames each with a small meerschaum between her lips. The lady pointed in horror to the smoke, and gazed at the porter; he pointed to the label on the car window (*Für Damen*) and stared blankly into the coupé. The case was not provided for in the regulations, and nobody knew what was to be done about it. Luckily a gentleman came forward at this point of the comedy, and handed the lady into the "non-smoking" car.

A similar case is related to have occurred in this country. As an American conductor was one day going through a

car he saw a woman smoking a pipe with great composure.

"Madam," he said, "we don't even allow men to smoke in this car."

"That is an excellent rule," she replied very coolly; "if I see any man smoking in here I'll inform you at once."

*Speed* is held by the people of this hurrying age to be one of the chief luxuries of a journey by steam. And so it is if every precaution is taken against accidents. It is a mistake to think that there is any more danger in running a train at the rate of forty miles an hour over a good road than at twenty-five an hour. The reasons why it is safer to drive an engine sixty miles an hour now than it was twenty miles an hour twenty-five years ago, are these: we now have the Miller platform and buffer, which closely bind the different cars together and lessen the danger of derailment; the rails are jointed with fish-plates; there are five cross-ties now where there were three formerly; locomotives and cars are built stronger than they used to be; and most roads are provided with experienced train-despatchers and telegraph operators, and a system of electric signals. Assuming the tensile strength of a Bessemer steel car-wheel tire to be one hundred and twenty-five thousand pounds per square inch, and taking twenty-five as a factor of safety, it is certain that the wheel can safely revolve so as to attain a speed of one hundred and fifty miles an hour. But such a high rate of speed would be uncomfortable and costly. It is five times as expensive to run a train at sixty miles per hour as it is at twenty; both speed and steepness of grade are costly in the matter of expenditure of power. But the motto of the day is "speed at any cost," and the railway companies must meet the demand.

It is a fact not often recognized that extremely high rates of speed were attained in the very earliest days of the railroad. Mr. I. K. Brunel, engineer on the Great Western railroad, England, advertised in the "Mark Lane Express" in 1841, that he would perform a match from Bristol to London by the engine called "The Hurricane," within two hours. This was at the rate of sixty miles the hour. In the "Illustrated London News" for August 10, 1844, it is stated that the journey by rail from Slough to London (eighteen miles) was accomplished in fifteen minutes and ten seconds; and Mr. R. Dymond, F.S.A., states in "Notes and Queries," January 8, 1881, that in 1846 he travelled with Brunel over the South Devonshire railroad at a speed of seventy miles an hour. And to this day English trains are thought to exceed ours in speed by from twenty to twenty-five per cent, their freight trains running as fast as our expresses, or thirty miles an hour. But a correspondent of the New York "Evening Post" writes from London that critical examination does not sustain the accepted notion of the superior velocity of English trains. He states that the rates for England are forty-one to forty-seven miles per hour. The "Flying Dutchman," the famous fast train of the Great Western road, only makes forty-six miles an hour, while the Leeds Express attains forty-seven, and the Midland Scotch Express, forty-one. On the Continent there is a train running from Berlin to Hanover that travels fifty-one and seven-tenths miles per hour; and a through train now runs from St. Petersburg to Paris, without stoppage, at the rate of fifty-six miles an hour. The fastest trains in this country are those between New York and Philadelphia over the Bound Brook and the Pennsylvania Company's routes. These average forty-five to forty-seven miles an hour,

and sometimes make sixty miles in sixty minutes. An engine built by the Baldwin Locomotive Works ran ninety miles in ninety-eight minutes; the English feature of a single driving-wheel on each side instead of two, gave this engine its advantage. For a high rate of speed over long distances the New York and Chicago Limited beats the world. It whirls over the nine hundred and thirteen miles that separate the two cities, in twenty-five hours.

They seemed to take things in a good, old-fashioned, leisurely way, on some of the English roads at least, in the year 1859, if we may judge from the following incident taken by the author from the London "Times" of that year. It relates to the *Stopping of a Train by Mushrooms*: An English traveller, who was passing over a railroad on the English side of the border-line of South Wales, says: "We happened to pass a field strown with a most luxurious growth of mushrooms. I had hardly remarked the circumstance to my companion when we felt the train suddenly stop, and looking out to the front, we saw, to our astonishment, the driver jump off the engine, vault over the fence, and proceed to fill his hat with the treasure. In a moment the guard was over the fence following his example, which, as may be supposed, was infectious, for in less than half a minute every door was thrown open, and the field covered with the passengers, every one of whom brought back a pretty good hatful."

## CHAPTER XIII.

### THE LOCOMOTIVE AND ITS MASTER.

Staym-ingynes, that stand in lines,  
Enormous and amazing;  
That squeal and snort like whales in sport,  
Or elephants a-grazing.—THACKERAY.

**G**RIP AND GO are the requisites of a good locomotive, says Mr. F. Scott Russell. The enemy of grip is slip; damp makes slip, but dry gives grip. That is to say, a locomotive gets a better bite on a dry rail than on a wet one. When the iron wheel rolls over the track, a weight of seven tons causes a grip of one ton. At least, in dry countries this is the case. But in moist countries it takes a weight of ten tons to give a grip of one ton. It follows, therefore, that to increase the traction of an engine you have only to increase its weight. But a limit is practically set to this increase; for a very heavy locomotive tears the rails all to pieces, unless the weight is distributed over two or even three pairs of coupled driving-wheels. The application of this principle of numerous driving-wheels in America has resulted in the production of monster engines. The hierarchy in order of size is (1) "Camel-backs," (2) "Moguls," (3) "Consolidations," each of these having an increase over the one preceding, in the number of its driving-wheels. Our locomotives differ much from those of England. English engines have no springs, and are built for straight and level roads. They would continually be jumping the track of our roads. American engines are flexible machines,



being hung upon springs or upon the fulcrums of a system of levers balanced equally in every direction. Now, if, owing to the inequality of the road, the wheels are at any time wrenched out of a level position, the frame work of the locomotive is not thereby wrenched, but self-adjusted to the rails. This flexibility of the truck also prevents derailment. Our engines are also furnished with an ingenious mechanism for shifting the weight as the locomotive turns a curve. By means of this device the locomotive can lean over toward the inside of the curve, and then gracefully recover its equilibrium, like a circus-rider in the ring. The inventor of the essential principle of this truck is John B. Jervis, builder of the Delaware and Hudson canal.

There was a double reason for the use of a cab on American engines; first, to protect the engineer and fireman from the smoke and flame issuing from the wood-burning locomotive, and, second, to protect them from the great extremes of temperature and weather that characterize our climate. The early engines were without spark-arresters, and the flame often streamed backward as far as to the engineer; and even now, when a locomotive is drawing a heavy load, the exhaust steam causes such a vacuum in the funnel, and draws the air so strongly through the fire and along the boiler tubes that the flame pours out of the top of the chimney a foot in length backward, in a crimson plume, while the engine itself is humming like a threshing machine. The beauty of the smoke as it rolls from the funnel has already been alluded to. A cunning old hawk in France has found other than æsthetic uses for this black cloud of smoke. The old pirate has, for fifteen years, been in the habit of hiding himself in the smoke and steam of the railway trains running between the stations of Mesgviny and

Romilly, for the purpose of more easily pouncing upon the small birds that fly up from the grass and bushes upon the approach of a train. The rascal knows that they cannot see him in the smoke and steam, and he flies slow or fast with the train, until he sees an opportunity to make a meal. In the same way fowls will follow a horse or a cow about a meadow to catch the insects disturbed by the grazing of the animals.

The fire-steed always has a good appetite; he will toss you down one thousand two hundred gallons of water and a cord of wood every hour, and make nothing of it. He is not very fastidious about his dishes, either, and when wood and coal have given out, he has been known at various times to devour (*fressen*) such strange things as pigs, mummies, fence-rails, peat, straw, and petroleum. Straw-burning locomotives were exhibited at a Vienna Exposition a few years ago, and recently Russian locomotives have employed petroleum for fuel.

The average life of a locomotive is thirty years. At the end of eleven years a sum equal to its original cost has usually been expended upon it. An engine is considered to be doing good service if it runs two hundred and fifty days in a year. It is evident that a machine consisting of five thousand four hundred and sixteen pieces, cannot be subjected to the terrible jolting and strain and soilure of rail travel more than two or three days, without needing more or less repairing and cleansing. Indeed, the iron horse needs rest and careful tendance, even more than a horse of flesh and blood. After a thousand miles' run it is found that joints have become relaxed, bolts loosened, rubbing surfaces often unequally expanded (by heat or cold) or strained and twisted, the grate-bars and fire-box choked with clinkers,

and the tubes obstructed by coke. It is then that the engine-cleaners show themselves in all their glory. They take the black giant into the stable—these greasy-capped grooms and hostlers—clean out the fire-box, scrape the grate-bars, tighten the bolts and rivets, thoroughly oil, cleanse, and polish all parts subjected to friction, and allow the heated surfaces to cool down, until, at the end of six or eight hours, the engine is again ready for service.

Speaking of engine-cleaners, a curious incident is told of one formerly in the employ of the Chard and Taunton Railroad Company, in England. His name was William Stevens. One midnight William took it into his head to have a ride on the locomotive "Busy Bee." Accordingly he kindled the fire, and when he judged he had a sufficient head of steam, pulled the throttle and started off. But he did not know how to compress the steam, and it blew off in every direction, with terrific noise, to the bewonderment and alarm of the awakened inhabitants of the neighborhood. Up and down the track he tore in this manner for two mortal hours, his face white with suppressed excitement, as the watchman by the bridge reported, but yet enjoying his ride amazingly. Once as he was on the point of entering the main line of the Bristol and Exeter road, he fortunately heard the whistle of the approaching night mail for London, and backed away just in time to avoid a terrible catastrophe. At length he returned to the station, got off the engine, and lay down by its side to await the coming of the engineer. At four o'clock the engineer was walking toward the station, and when within a hundred yards of his locomotive, suddenly saw it blown to pieces before his very eyes. It appeared that the rascally engine-cleaner had exhausted all the water in the boiler, and neglected to turn

on more. Strange to say, the blockhead received no injury, owing to his being on the ground when the explosion occurred. But if the "Busy Bee" was prevented from inserting her vindictive sting into her destroyer, she was none the less revenged, for the sentence pronounced by the court was imprisonment for one month at hard labor.

This incident calls to mind another which happened on a railroad near Holyhead, North Wales. One day a signalman on the line was astonished at seeing a "wild" engine come thundering along the track at a prodigious rate, and paying no attention whatever to his signals of danger. Now the Irish mail was nearly due from the opposite direction, and a terrible collision seemed inevitable. Suddenly it flashed across the mind of the man that the engineer and fireman must be asleep. He telegraphed at once to the next station to put fog signals on the track. His surmise was correct; the fog signals stopped the engine, and it appeared that the men had been fifteen hours on duty, and had both been sound asleep. The water had disappeared from the boiler, and the fire was nearly out, so that, but for the prompt action of the signalman, they would have been killed by the explosion of the engine, even if the Irish mail had spared them. They were both immediately discharged; but not with much justice, it would seem, when one considers that the cause of their misfortune was the greed or neglect of the company in keeping them so long on duty.

The life of a locomotive engineer is not an enviable one. Apart from the wearing sense of responsibility, and the strain and jar received by the nervous system, there are certain popular opinions which must be defied. For instance, it is the firm conviction of nearly everybody that

it is high treason for an engineer to jump from his engine in the face of an approaching collision or wreck. Now, as a matter of fact, after the air-brakes have been applied, the engine reversed, and the sand-pipe opened, it is *generally* mere folly for the driver and fireman to stay in the engine, with the certainty of an approaching collision. The men are of no earthly use upon the engine after that, and if they do not jump, it is because they have not time, or are too foolhardy. In most cases, then, the popular talk about the "glorious heroism" of the engineer who "refused to desert his post," and "died with his hand on the reversing lever," is all nonsense, and it is too bad that the gross ignorance of people should lead them to exact of locomotive-drivers a course of action which is fatal to them without being of the slightest use to anybody else. The majority of engineers are, by training and by necessity, men of physical courage and moral stamina, and should be allowed to judge in each case what risks they ought to take. Time and again the newspapers of Europe and America publish instances of the self-sacrificing devotion and heroism of locomotive-engineers who staid by the engine *when it was necessary* for the welfare of the passengers that they should do so. A single instance will answer for many:—

On October 22, 1882, the 1.15 P.M. local train of the Pennsylvania railroad left the Jersey City depot as usual. Every car was crowded, and in the smoking-car standing-room was scarcely to be had. There was no baggage-car, the tender of the engine being attached directly to the smoking-car. Suddenly, the door of this car was burst violently open, admitting a gust of flame and smoke, out of which engineer Joseph A. Seeds and his fireman emerged, shutting the door behind them. They had been driven

out of the engine by the flames which had poured out of the furnace-door and set the cab on fire.

Great excitement arose; the smoking-car was immediately packed full of terrified people eager to know what had happened. The engineer ordered his fireman to use the lever of the air-brake in the rear of the smoking-car, and stop the train; but it was impossible for the man to stir an inch, so great was the crush in the aisle. "What is to be done?" was the cry. The engineer said nothing, but was seen to set his teeth hard as he sprang upon the tender and disappeared through the smoke and flame. Presently the train slackened speed, and then came to a stop on the river-bridge. It was an easy matter to draw up water and extinguish the fire. But the brave engineer was found lying on the tank of the tender, in an unconscious state; his clothes were burned from his body, and it was necessary to lift him down with great care to avoid removing the skin from the flesh. He was taken to the hospital, and died in a few days. You will not find nobler heroism in the world than this. Engineer Seeds died to save the lives of those passengers, and if they did not provide for the widow and children he left behind him, it is to their everlasting shame and disgrace. It was suggested at the time by the New York "Tribune" that a purse be made up, and we will hope, for the honor of human nature, that this was done.

One who dips a little way into the railway journals of the West soon discovers the existence of a curious kind of railway yarns, full of enormous exaggerations, distortions and improbabilities, highly colored with a peculiar kind of rhetoric. These yarns, like those of sailors, always have such a distinctive stamp of improbability upon them

that you recognize them at sight as fabrications. They generally purport to have been told by some tough old engineer or fireman, and relate to his terrific adventures by rail. But there are, of course, a great many genuine locomotive stories to be picked out of the chaff. A writer in "Lippincott's Magazine," for instance, tells how a conductor was chased by a locomotive. The old Long Island railroad, at the time when the incident occurred, was a single-track affair with numerous switches and sidings. One pitch-dark night, when the conductor was taking three passenger cars through to Greenport, and had got about six or eight miles on his way, he noticed the head-light of a locomotive in his rear. He was thunder-struck at the discovery, and as he gazed, his astonishment grew into deep apprehension, for he saw that the locomotive was rapidly gaining upon his train. He went forward and ordered the engineer to put on more steam, and then ensued a wild chase of many miles through the night, both train and pursuing locomotive tearing along at a high rate of speed, and throwing out showers of sparks from the wheels. Everybody on board the cars believed the engineer of the pursuing locomotive to be either mad or intoxicated. At last the fireman conceived the happy thought of oiling the track in the rear of the train, since a locomotive can make no progress on greasy rails. This device saved the train from disaster. The anointing of the track with the contents of two huge cans of kerosene for half a mile soon caused the head-light of the chasing locomotive to grow dim in the distance. The train was stopped, and then backed up that the mystery might be investigated, the conductor and engineer, in the meantime, preparing to give the drunken driver of the "wild" locomotive a merited

castigation (in words). But when they neared the head-light a laughable scene was presented. "There stood the old 'Ben Franklin,' puffing and snorting and pawing like a mad bull, the driving-wheels buzzing around on the greased track like all possessed, but not gaining an inch." Sanding the track, they bore down on the old machine, but no sign of an engineer or fireman was to be perceived. There was a full head of steam on, but the fires were getting low. Pushing back to the next station with the runaway engine, the conductor sided his cars just in time to avoid the down train, and was then handed a despatch telling him that the "Ben Franklin" had broken loose, and ordering him to switch it off at Lakeland and wreck it. But the oiled track had saved them that trouble, and had also saved "Benjamin" from a smash-up.

Locomotive runaways, such as the foregoing, are by no means rare occurrences. Not long ago two engines collided on a track of the Boston and Maine railroad, in Tewksbury. The shock opened the throttle valve of one of them, and as the engineer had jumped from it, it started down the track alone toward Lowell. Reaching the end of the track at the Lowell station, "it overturned the bunter as if it were a mere wisp of straw, went ploughing through the floor of the station for a distance of seventy-five feet, and entered the express office. It crashed through the partition separating this office from the station quarters, and also wrecked one end of the baggage room in passing. As it entered the express office, four persons were present and endeavored to escape. Two got out by way of the door. One was behind the counter, and only had time to leap on the desk when the puffing engine reached him. A plank was hurled against the door and pinned him in close



quarters, but inflicted only slight injuries. Meanwhile the engine was grating its head against the brick wall which adjoined the public sidewalk, and tore out quite a section, besides all the windows, when fortunately the floor gave way, and it fell into the basement, emitting clouds of steam and smoke. The fourth occupant of the express office was carried down into the cellar with the engine and debris, and was completely, though lightly covered, resting face downward just under the headlight."

An English journal some years ago gave its readers an entertaining account of a fight for a locomotive. The machine had been seized (illegally, as the owner thought) for debt, and sold for a quarter of its value. The writer in the journal, who was the chief actor in the adventure, tells the story in the first person. He received orders from the company by which he was employed, to go at once to the place where the engine was, procure a number of men and horses from the lead mines near at hand, remove the machine on to the main line after the night mail had passed, and take her to Nantygolyn station in time to meet the up luggage train at 2.30 in the morning; then to attach her to that train and so fetch her to the company's quarters. Let us now permit the hero of the occasion to tell his own story:

"The wind was rising, laden with occasional showers, as I reached the brick-field. The state of affairs was worse than I had imagined. The engine had been left on an exposed part of the line, and where there was a sharp curve, causing the outside rail to be much higher than the other. Inclining at such a sharp angle, it had been exposed to the full fury of a recent gale, which catching it at so great a disadvantage had tilted it completely over, and it now lay

on its side on the embankment, with the hindermost wheels, however, resting on, or only partly off the rails. It was a small and very light engine, and had been originally intended for the Crimea. It was a wild and lonely place where the brickyard was situated. It was just where the moorland commenced and where there was nothing to interrupt the eye as it roamed over the purple flat, strangely lit up in places by crimsoning gleams and patches of golden brown as the light of a stormy sunset was reflected from the surface of a pool, or shone on a lighter ground of dead rushes and ling. Beyond all, was a long gray line which could not be mistaken for anything but what it was, the bonny, open sea. If you listened intently you could even catch, borne on the wind, the faint roar of the surf on the flat, sandy shore."

His men, he goes on to say, were duly employed, and, when night came, rigged up a crane, and were trying to raise the fallen engine, when suddenly they discovered forms flitting through the darkness around them; they were the vanguard of the enemy, the force got together by the late purchaser of the engine for the purpose of saving his property from recaption.

"'Look sharp, lads, and get her on the line before they come,' I cried, and lent a hand to the ropes myself. At last with a thud she was righted, and then the screw-jacks were again applied to lift her properly on the rails. This was done without interruption. The horses were harnessed to, and she began to move merrily enough, though a rattling noise inside made it evident that some of her machinery was broken. I was beginning to hope we might soon gain the main line, about half a mile away, when over the bank there came some twenty or thirty men and lads. The

wheels were scotched before we could prevent it. They harnessed a couple of horses and half a dozen donkeys to the other end of the engine. Two tar-barrels they had brought with them were set alight, and blazed furiously, affording plenty of light. I warned my men not to have recourse to violence, and in this I was seconded by the leader of the opposite side, who was, in fact, the purchaser of the engine.

“‘It shall be a fair fight,’ he said. ‘Let us see which can pull the hardest now, and you take your chance in the law afterward.’

“By mutual consent we unscotched the wheels, and the tournament began. First one party gained a few yards, then the other. The animals lugged their very hardest, aided by the men. The Englishmen were the strongest, although the fewest in number, but the incline was in favor of the Welshmen, and at first it seemed as if they would triumph and drag the engine back to where the rails were broken up. No blows passed between us, and the good humor shown by everyone surprised me much.”

After a great deal of lugging, and tugging, and scotching of wheels, during which neither party gained any advantage, a bright idea occurred to the leader of the company's party. He went up to one of his men, and asked him which was the best runner in their party.

“‘There will be none as good as you, sir; and they be all tired with this pulley-hauley work.’

“‘Well then, I'm off to Nantygolyn station; and I'll come back with the engine of the luggage train. Do you see? Look to the points at the junction.’

“‘Capital, sir!’ exclaimed he, as I turned and dashed over the bank and into the narrow road. I had scarcely got out of the glare of the fire when I was roughly collared by

somebody. As he was evidently not a friend, and there was no time for an explanation, even if I had wished to give any, I placed my hand over his shoulder and my arm under his chin, and with a sudden wrench, taught me by a Welsh collier, forced his head back and left him half insensible on the ground."

Covering the two miles in about a quarter of an hour, the agent returned with the engine, which steamed slowly up to the scene of contest.

"Both parties had drawn off their forces, and were sitting and standing in groups a little apart, while rude chaff was freely interchanged. The firelight cast long and wavering shadows around, and made the outer darkness look blacker and more impenetrable than ever. The rain still came steadily down and hissed on the blazing fires, while the wet ground was trodden ankle-deep.

"Such a yell arose after the first astonished silence, from our opponents, answered back by a ringing cheer from my men. The cattle were quickly unloosened and ridden off out of the way by the men. The ropes were quickly transferred to the big engine, and in the midst of a general *mêlée* the two locomotives moved slowly off, dragging their horses and donkeys backward. Seeing the uselessness of employing brute force against steam, they cut their ropes, and we moved triumphantly off, followed by a volley of oaths and stones. One of the latter struck me on the cheek, laying it open and knocking me back on the coals in the tender. It was as much as I could do to restrain my men from jumping off and charging them. Well, that is how I fought for and won the locomotive."

## CHAPTER XIV.

### THE TRACK.

Sling up the bugle! harp and lute,  
Let every dusty string be mute,  
Be still the drum and dumb the flute,  
While trumpets blow so brave and loud,  
They rally like a flag unfurled  
And wake and warn the startled world —  
The trumpets of the "Flying Cloud."

BENJ. F. TAYLOR, "The Flying Heralds."

THE womb of a steel rail is the Bessemer "converter." When the roasted iron comes out of the blast furnace as pig iron, it is cast into the huge converter to be made into steel by an admixture of carbon. But it already has some carbon in it, and we want first to get rid of that, because we don't know exactly how much it is, and then we can add our own carbon in carefully measured amounts. They remove the carbon from the pig iron by blowing air through the converter, for the oxygen of the air unites with the carbon and passes off with it in a long body of flame of a surpassingly beautiful and dazzling whiteness. The process takes twenty minutes, and all the while the foundry is filled with the heavy roar of the blast, the volcanic undertone of the rumbling metal, and showers of sparks blown out of the aperture in the vessel like tiny rockets or scintillating stars. Do you see that man watching the terrible white flame with a spectroscope? He is anxiously looking out for the moment when the decarbon-

izing process is complete, for then the spiegeleisen must be added, and the gold liquor poured glowing hot into moulds. The moulded masses are made into "blooms" by being repeatedly passed through the jaws of a mill, and then they are ready to be stretched out into rails. It is a weird sight to see men handling the long red-hot rails in a foundry at night. They look like demons in the red glare as they draw the long rails from the furnace with tongs, and run to and fro with them in the shadowy light—their blows rapid and their movements excited, as if they were forging some hellish machine for the torture of the damned. But we do them wrong; every blow they fetch forges another link in the iron bonds that are uniting the nations of the world together in peace and good will. The rail-forgers as well as the rail-splitter deserves our respect.

On the subject of Gauges there is a word to be said. Most of the railroads of the world have a gauge of four feet, eight and a half inches. This was the width of the colliery tramways in England, and was adopted by Stephenson as the gauge of his first roads. It is now made compulsory to use the four-feet, eight-and-a-half-inch gauge in England, Belgium, France, Italy, and Germany, and it is everywhere called the standard gauge. Unfortunately in the United States there are all sorts of gauges, although the standard predominates. Some roads adopt the expedient of lifting through trains bodily from the trucks and running under them the trucks of the connecting road. A through train from St. Petersburg to Paris, in Europe, has recently been fitted up with adjustable wheels, suited for any gauge. The broadest gauge ever used for a railroad was that adopted by Brunel for the Great Western in England. As

the rival of Stephenson, he must do anything but imitate him; so he built a road seven feet in width, claiming that travel on such a road was safer, swifter, steadier, and more comfortable than on the standard road; besides that, more powerful engines, and cars of greater capacity, could be employed. But the expense of such a gauge proved fatal to its profitable use, and after twenty years of trial Brunel's broad gauge gave place to a narrower one. The same thing has happened to the Atlantic and Great Western railroad in this country, and it seems probable, or possible, that the Erie, the Ohio and Mississippi, and the Grand Trunk lines will follow suit.

The first advocate of a narrower gauge than the standard was Robert Fairlie. The Denver and Rio Grande was the first narrow-gauge track laid; and since that, sixteen thousand miles of the narrow roads have been built in this country. The narrowest of practical narrow railroads thus far built was constructed in 1874, by Mr. G. E. Mansfield, the railway constructor, for his own use, at Hyde Park, Massachusetts. Its width was only ten inches.

The Stations of the early railways in this country were mere sheds open on two or more sides to the wind and dust. Later, in the larger cities, huge brick barracks, than which nothing could be more dismal, served as points of embarkation and arrival for passengers. There is still little of attractiveness or homelike elegance about the stations of Great Britain and America; and all the poetry connected with these disagreeable abodes is to be found outside, where, in watching the coming and going of the swift trains, one finds much to admire, especially when the colored signal lamps are swinging at night, and the electric

lights are throwing their intensely defined, almost solid, shadows around.\*

There is no good reason why railway stations should be such lugubrious, hideous places. A recent traveller on the Continent remarks that the stations of Switzerland are built in the style of picturesque cottages with wide eaves, ornamental cornices, and graceful balconies; most of them are surrounded by little gardens, and some "are fairly enchanting with their wealth of climbing vines." A fountain dancing to its own music in the midst of the blossoms is not unfrequently seen. At Milan the passenger station is a crystal palace with frescoes of Italian masters upon its walls, while the baggage of travellers is wheeled over noiseless floors upon trucks with rubber tires. In Florence a railway waiting-room is furnished in black walnut and crimson plush; a whole conservatory of flowers blossoms under the wide skylight, and marble statuary is embowered in orange-trees, while huge multiplying mirrors fill up the panels in the walls. At Verviers, a little Belgian town on the French frontier, the walls of the station are hung with

\* Here is Dickens's picture of Mugby Junction, painted as if by a somnambule:

"A place replete with shadowy shapes, this Mugby Junction, in the black hours of the four-and-twenty. Mysterious goods trains, covered with palls [in England they cover their open freight cars with black tarpaulins], and gliding on like vast, weird funerals, conveying themselves guiltily away from the presence of the few lighted lamps, as if their freight had come to a secret and unlawful end. Half-miles of coal pursuing in a detective manner, following when they lead, stopping when they stop, backing when they back. Red-hot embers showering out upon the ground, down this dark avenue and down the other, as if torturing fires were being raked clear; concurrently, shrieks and groans and grinds invading the ear, as if the tortured were at the height of their suffering. Iron-barred cages full of cattle jangling by midway, the drooping beasts with horns entangled, eyes frozen with terror, and mouths too: at least they have long icicles (or what seem so) hanging from their lips. Unknown languages in the air, conspiring in red, green, and white characters. An earthquake, accompanied with thunder and lightning, going up express to London."



dark-green velvet paper; the long windows that reach to the floor are curtained with heavy damask, and full-length portraits in oil are hung upon the walls. The nearest approach to all this in America has been made by the Boston and Maine railroad, which allows its rural station-agents ten dollars a year for seeds, plants, etc., and offers annual prizes of twenty dollars, thirty dollars, and fifty dollars, each, to those whose stations are most tastefully and carefully kept. The directors of a railroad running south from Philadelphia keep a salaried gardener to attend to the grounds about the various stations. These two instances are the only ones that have fallen under the writer's notice.

No subject connected with railways is so little understood by the public in general as that of Signals. And there is good reason for its ignorance, since there is the widest discrepancy in the signal-practice of different roads. The various means of signalling a railway train are,—hand and lamp signals, bell-cord signals, whistle signals, stationary fixed signals, switch targets, danger signals for rear protection, torpedo signals, the telegraphic despatch, and the automatic electric signal. A pretty generally understood code of signals in America is the following: "Go ahead"—an up-and-down motion of the hand, or parting the hands outward from the level of the face; "Stop"—a motion crosswise with the track, or a downward motion of the hand; "Back up"—moving the arm in the arc of a circle over the head, at the same time twisting the body until the hand is pointed almost in the direction the train is to move. "Train parted"—a motion in a vertical circle at arm's length across the track, given continuously until answered by the engineer. One blast of the whistle means "stop," or "down brakes"; two blasts, "go ahead," or "off

brakes"; continued whistling means "danger"; the cattle-alarm consists of a succession of short, sharp blasts. A red flag waved on the track means "danger"; if stuck up beside the track, "danger ahead"; carried unfurled on the engine it means "another engine is on the way." A green flag denotes "caution, proceed with care"; a white flag means "safety, track clear"; one torpedo-signal indicates "danger"; two torpedoes, "caution"; one pull of the bell-cord means "start"; when the train is running some conductors give one pull for "stop," and some give two; three pulls means "back up." Usage differs so much in the case of signals for rear protection, and many kinds of stationary fixed signals, that no general rules can be given for these.

The *mechanical* signalling done by railroads may be conveniently classed under two heads,— (1) telegraphic work for long distances, and (2) station, or switch work. It was some time after the invention of the telegraph before railroads could be got to adopt the new invention. The first to employ it for the purpose of controlling the movements of trains was Superintendent Charles Minot of the New York and Erie railroad, in 1850. Previous to this, the chronometer, the hand-flag, and a few fixed signals were the only means employed in this country for the avoidance of collisions. The first fixed railway signal in England was that adopted by the Grand Junction railroad, in 1838. It consisted of a disk fixed on a spindle, with a handle to turn it; a lamp took its place by night, the whole constituting merely a danger-signal.

It suggestively marks the additional element of safety afforded in this day by the use of the telegraph, to read, in an old American work on railroad accidents, of a catastrophe that happened to a train on the Lowell and Nashua

railroad, on July 5, 1841. There were a large number of persons in Nashua on that day, who had been celebrating "the Fourth" and were anxious to get to Lowell by the last downward train of cars. Accordingly, the superintendent at Nashua directed a conductor of one of the trains down to inform the superintendent at Lowell that he must not send the last upward train as usual. By some neglect this information was not received, and the train was sent up. The consequence was that as the two trains were going round a curve at "great speed" they collided, smashed their engines and "severely wounded four persons, one of whom it was thought would not survive the accident." We may smile at the low rate of speed that must have been in vogue when the collision of two trains of cars going at "a high rate of speed" resulted in so comparatively slight a calamity as this; but the incident points the contrast between that day and this in the matter of signals. If the telegraph had been in existence, with the present accurate system of checks applied to train-despatching, no accident would have occurred.

The strain of responsibility upon the train-despatcher of a great railroad in this day seems almost unendurable to an outsider. There he sits in his office at headquarters, like a magician, and, gazing on his chart, directs, by the aid of a telegraphic assistant the movements of a whole army of flying trains scattered along the tracks for a thousand miles. They dare not move without his order, but as soon as the far-whispered word is received they start on, and woe to the despatcher, if he has lessened for a moment the lynx-eyed vigilance that is the price of his position and of the safety of the trains. Before his eyes is a chart containing the numbers of every train moving on the road at

a given time; at all hours of the day and night come telegrams from the local stations, announcing the number and moment of arrival and departure of every train, and this information is at once written on the chart, which also has printed upon it the names of all the stations, the number of miles from one to another, and the time required to pass between them. Having, then, all this information before him, the despatcher proceeds (if he uses the Double-Order System) to telegraph at the same time his commands to the two trains that are waiting to pass over the same track, each in opposite directions. To one train he says "stay," and to another "go." Both conductors repeat the message to him; if they differ in understanding it, they are set right; if the despatcher himself has erred, he is twice reminded of it, and is given a chance to correct his mistake before sending his final order.

Now suppose a train is wrecked: immediately everything is disarranged; the despatcher must stop perhaps half a dozen trains scattered all along the line from five to fifty miles from the accident; and if one were watching the scene from a balloon, he would see what looked almost like the movement of connected automatic machinery along the line of track, so quickly would freight trains be seen to roll out upon sidings, and passenger trains stop short where they were, in obedience to the orders received on the wires. The obstruction having been removed, the train-despatcher sets his flyers in motion again on his iron chess-board, watching their movements with the utmost intensity of concentration.

The system just described is used on single-track roads. On double-track railways the somewhat similar block

system is used.\* Block-working is a system of dividing up a track, or road, into a certain number of sections of such length as may be most convenient for traffic, and insuring that only one engine, or train of cars, shall be on one division at any given time. This is accomplished in England, and on such American roads as the Pennsylvania Central, by having train-despatchers, or local telegraphers, at every block-station, and no train dare enter upon the section until it has received information from the telegrapher that the track is clear for its whole length. In the present state of automatic electric signal-systems, this English plan is the safest, although more expensive. It is hoped, however, that automatic signals may be so perfected as everywhere to supersede the English system.

The automatic apparatus operates the signals by means of the rail circuit, with a closed circuit for keeping the signal at safety. A broken rail will put the signal to danger, as well as the entrance of a train upon the section. The signals have an overlap of one thousand feet, and there must be at least that distance between trains. The greater the density of traffic, the shorter the block sections should be. The signal of the automatic apparatus is usually a pivoted disk placed upon a high pole, and painted with one face red and the other white. The signal most used in Great Britain (and extensively in America) is the semaphore (*σημα*, a sign, and *φέρειν*, to bear); it is a tall, vertical post, with movable arms and lights near the top.

In Great Britain they used to have what was called the

\* Probably so named from the facility it affords for blocking the line by signalling back.

“Train Staff and Ticket System,” for single-track roads. This was a block system, too. The road was divided into sections, each of which had a staff, or truncheon, usually of a different color or length. When an engine-driver appeared at a station he was not allowed to proceed over the next section unless he received the staff from the station-master. If he did not receive it, the inference necessarily was that some other engine-driver was then carrying it in one or the other direction over the section. As there was only one staff, and a ticket of permission was given the driver along with the staff, the system evidently insured perfect safety. But it was a clumsy and primitive method,—too much like the notched-stick system of notation to suit the fancy of railroad officials after the invention of telegraphy.

But it is at the signal and interlocking towers and cabins of the great stations and railroad junctions that the most marvellous achievements of mechanical ingenuity are revealed. In a little glass box hung over the middle interior of the Grand Central Depot in New York sits a magician who controls the entire activity of the place. He is surrounded by the implements of his magic,—broken lightning, electric knobs, regulator-clock, and telegraphic instruments; and it is at his beck and nod that the two hundred and fifty trains a day come and go. So in London there is a signal-station called by railroad men “The Hole in the Wall,” where the railroads of all Southern England converge upon two lines of track. The hole in the wall is the lookout for the signalman; he too is surrounded by mysterious agencies; and bells ring, hands move, huge iron bars creak and groan, and automatic signs start suddenly forth from the wall to inform the operator that the swift express or mail below awaits his permission to enter or depart.

The interlocking system of switches is, to state the matter in a few words, the complicated massing of a large number of switch-levers in one cabin or gallery, and connecting them by locking safety bars which permit them to occupy certain unalterable positions only.\* The plan is such that there can be no possible contradiction between the state of the switch and the signal given. It has been said that if a piano were constructed in such a way that the operator could strike on it harmonious chords only, it would resemble the interlocking system of signals. At the Cannon Street station in London there are nearly seventy point and signal-levers concentrated in one signal house, and the "number of combinations which would be possible if all the signal and point-levers were not interlocked can be expressed only by millions. Of these, only eight hundred and eight combinations are safe, and by the interlocking apparatus, these eight hundred and eight combinations are rendered possible, and all the others impossible. If a man were to go blindfold into this signal-house, he might so far as accordance between switches and signals is concerned, be allowed to pull over any lever at random." These are the words of Charles F. Adams, Jr., who further says: "It may well be questioned whether the world anywhere else furnishes an illustration so apt and dramatic of the great mechanical achievements of recent times as that to be seen during the busy hours of any week-day from the signal and interlocking galleries which span the tracks as they enter the Charing Cross or Cannon Street stations in Lon-

\* Barry's work on "Railway Appliances" contains the best technical and detailed explanation of the block and the interlocking systems. See also C. F. Adams, Jr.'s work on "Railway Accidents." The interlocking apparatus has been recently introduced into the United States, the machinery of the Union Switch and Signal Company being found on many of our railroads.

don. Below and in front of the galleries the trains glide to and fro, coming suddenly into sight from beyond the bridges, and as suddenly disappearing,—winding swiftly in and out, and at times four of them running side by side on as many tracks, but in both directions;—the whole making up a swiftly shifting maze of complex movement, under the influence of which a head unaccustomed to the sight grows actually giddy. Yet it is all done so quietly and smoothly, with such an absence of haste and nervousness on the part of the stolid operators in charge that it is not easy to decide which most to wonder at, the almost inconceivable magnitude and despatch of the train movement, or the perfection of the appliances which make it possible.”

In a similar strain writes Mr. W. J. Stillman in “The Century”: “Neither the sounds nor the sights of London impressed me as did its labyrinth of railways; no other evidence of the power and intelligence of England has ever seemed to me like this stupendous accumulation of engineering accomplishment. \* \* \* If you want to see what the traffic of London is like, go to Clapham Junction where the great railway systems connect. The rails lie together like the wires of a piano. System and organization have done their best, and sixteen hundred trains a day pass and repass with safety. It is a bewilderment. In and out, coming, going, slow trains and fast trains; one side of you halts a train, and while you watch its wheels slowing, an express rushes past on the other side like a tornado of iron. \* \* \* It is a saying of the denizens about Clapham Junction that, on the average, one man is killed every six weeks. One wonders, after having watched the traffic a half hour, that some one is not killed every day. Look cityward and see the trains flying—diverging eastward,



westward, northward, line under line three deep, crossing each other, diving under, or going over, but never on the same level, and then sweeping, by long curves, round the huge circumference of suburban London, a girdle of iron, meeting, crossing, uniting, and separating again on the opposite side."

## CHAPTER XV.

### THE TRAIN.

THE most important thing about a car is its wheel, and a car-wheel is not, as might be expected, an easy thing to make. The processes involved in its manufacture are intricate and delicate in the extreme. The nicest point is to get a hard "run" or "tread" (the part that runs upon the rail). The method now used is called "chilling," and was invented by a Philadelphian in 1847. It is a process analogous to "tempering." The whole wheel is cast from the same metal in one pouring, but the outer portion of the mould consists of a ring of iron which has previously been turned upon a lathe to form the flange and tread of the wheel. Now when the molten iron is poured into the sand-mould, that portion of it which flows out to the circumference and comes in contact with the iron ring is instantly chilled, congealed, and crystallized to a depth of about half an inch in beautiful parallel filaments, as white as silver and nearly as hard as diamond. This happens because the cold iron is a better conductor of heat than the sand. All iron does not possess this invaluable chilling property. It has been discovered that silicon in just the right proportion is a necessary ingredient in good chilling-iron; and so nice must be the amount of this element, that it has often happened that an entire day's work of several hundred men has been rendered useless by an admixture with the iron of one-half of one per cent of silicon in excess of the requisite

amount. The chilling subjects the molecular structure of the wheels to an immense strain, and to correct this they are annealed by swinging them while glowing hot into heated pits, or burying them in hot sand. After several days have passed, it is found that the molecules have slowly arranged themselves in their natural position, and the strain is entirely removed.

Paper is about the last thing one would have thought of as material for a car-wheel; yet it is very serviceable for the purpose, and has been extensively used in this country. The "Railway Age" car, described on a previous page, has paper wheels with steel tires. The disk of paper, used in the manufacture of a wheel, is subjected to a pressure of a ton and a half to the square inch. Among the advantages claimed for the wheel are these: it is comparatively noiseless, and it does not shrink or spring with the weather.

After the wheel, the most important things about a car are the coupler, buffer, and platform. The sills and the platforms of most of the early American cars (but not the earliest; see the picture on page 67) were on different levels, so that the line of resistance was not the line of greatest strength. The consequence was that when collisions occurred, telescoping, with all its terrible accompaniments, was of the most frequent occurrence. Miller, the inventor of the platform, coupling, and spring buffer that go by his name, simply applied to cars the well known principle just spoken of,—that the line of resistance should be the line of greatest strength. In other words, he elevated the platform to a level with the car-sills, and coupled each pair of cars compactly and strongly together, so that now, on railroads using this platform, telescoping is never heard of. The Miller coupling consists of two spring hooks, or massive

clasps of iron, that are automatic in closing, and are unclasped by a hand-worked vertical lever attached to the railing of the platform.

When the stubborn prejudices of a railway company have been so far softened that they decide to adopt the Miller platform, they generally go farther and fit up their trains with the Westinghouse atmospheric brake, one of the most beautiful pieces of mechanism ever invented. The first patent of George Westinghouse was in 1869, and now the brake is used on nearly all the chief roads of Europe and America. The invention does away with the old wheel brakeman completely, since the entire train of cars can be stopped almost instantly by a simple turn of the finger and thumb of the engineer. A little steam-engine, affixed to the side of the locomotive, between the driving-wheels, operates an air-pump immediately beneath it, by means of which air is compressed into a large cylinder placed under the cab. From this cylinder a line of air-pipes runs back underneath the cars, connecting with a smaller cylinder under the centre of each car-floor. When a train is made up, the air-pipes of the cars are coupled by rubber tubes fitted at the ends with metallic valves, which are so arranged that when the two half-valves are joined they automatically open and thus complete a continuous air-tube extending beneath the entire train. When the tubes are uncoupled each valve automatically closes. Hence it follows that the valve at the rear of the train is always closed. Now suppose that by some accident a train should part in the middle after the engineer had applied the brakes, and suppose that at the same time one of the cars thus detached from the locomotive should jump the track,—the compressed air admitted to the cylinder beneath the derailed car before the uncoup-

ling occurred would still continue to act with full force upon the brakes, and would stop the car in a very short time. The forward cars might all plunge down with the engine through a broken bridge, or over a precipice, and yet the rear cars be brought to a stop by their self-acting brakes, before any accident should occur. It is admirable to see how quickly a train is stopped by this delicate brake. In 1871 a test-case was made on a train of the Kansas Pacific road, and it was found that the train when going at the rate of forty-five miles an hour could be stopped by the Westinghouse brake within a distance of two hundred and ten feet, or about four car lengths.

An amusing incident once happened on the Erie railroad in connection with the atmospheric brake. A train going westward was twice brought to a sudden and inexplicable halt by the application of the air brakes. When the train reached Hornell, and while the car-inspector was going his rounds, tapping the wheels to test their soundness, suddenly he perceived the brakes to be again turned on with the well known and unmistakable "sizzing" sound. A conference of the train men was now called, and some one suggested that a sealed express car be opened. This was done, and lo and behold! the mystery was cleared up. The car contained a baby elephant that had been consigned to a Chicago showman, and his rajahship had been amusing himself by pulling the air-brake rope which ran through his car.

The conductor's bell-rope is an American invention. The idea was first conceived by William Hambright, engineer, in 1833, on the old horse-power railroad between Lancaster and Philadelphia, and afterward a conductor on the Pennsylvania Central. Hambright affixed a common

door bell to the interior of the engine cab, and ran a rope from it backward over the top of the cars. The bell-rope at present in use was devised by Captain E. A. Ayres, of the Erie railroad. An old engineer of the Erie thus tells the story in the New York "Times":

"Once in a while the conductor found it desirable to eject some would-be deadhead passenger while between stations, but as there was no way to let the engineer know except by sending word by a brakeman, and as he usually had to climb over a dozen freight cars before he could attract the engineer's attention, it frequently happened that the train reached the passenger's destination before it could be stopped. 'Pappy' Ayres, the pioneer Erie conductor, got tired of this, and one day he tied a stick of wood to the end of a long rope, hung the stick in the engineer's cab, and carried the rope over the cars to the rear of the train. His idea was to pull the rope and agitate the stick of wood when he wanted the engineer to stop the train. He had to lick the engineer before the latter would consent to recognize such an innovation, but it worked to a charm, and led to the introduction of the now universal bell and rope system of signalling on cars."

Electric signal bells are in use on the Southeastern railway of England. The wires of the different cars are joined by electric couplings, so that the whole train is in electric connection. Passengers can signal the guard by pulling out from the side of the car a little handle resembling a bell-pull. The guards also have their separate set of electric signals, and the engine-driver has his. So that a guard can either signal a fellow guard or the engineer, as circumstances require.

Another use for electricity upon trains has been found

## 230 WONDERS AND CURIOSITIES OF THE RAILWAY.

in the lighting of cars. This was first tried in England on the Brighton railroad, October 14, 1881. The car used for the experiment was a Pullman, and the twelve little incandescent lamps employed gave out a fine, mild, equable, white light. In the same year a train running from Soissons to Paris was lighted by the electric flame, and shortly after the first experiment an entire train of Pullman cars on the same railroad was lighted by Edison's incandescent lamps. A peculiar method of lighting cars was tried recently on a train running through the Thames tunnel. It consisted in painting one-half of the car with Balmain's phosphorescent paint. The mellow phosphoric glow gave out light sufficient for the passengers to read their watches by, and proved a very agreeable substitute for lamps.\*

The Railway Post-office constitutes an interesting feature of the train. It is the invention of the English, the mail-car having been used there as early as 1837. Before the adoption of the system in the United States, postal matter was carried over railroads and common roads by United States mail agents. The first railroad agent was John Mitchell, of Baltimore, Md., who was appointed at a salary of eight hundred dollars, by the Hon. Amos Kendall (the postmaster general in 1837). Mitchell's route lay between Washington and Philadelphia, and he alternated in the

\* Before passing from the subject of cars and their appointments, we must notice a novel freight car recently invented in Boston. It is a non-freezing car for the transportation of potatoes in winter, and is provided with a kerosene reservoir and stove placed beneath the centre of the car. The reservoir supplies the stove automatically with oil, and the heated air is conveyed to air-chambers that line the top, bottom, sides, and ends of each car. The valve of the reservoir is so adjusted that the flow of oil increases as the cold increases. Three hundred of these cars have been constructed for the "Down East" potato trade, and they are also employed for the transportation of Florida fruits.

service with John E. Kendall, a nephew of the postmaster general.

Our present postal-car service was introduced by Colonel George B. Armstrong in 1864, and the first cars fitted up on the new system were run between Chicago and Clinton, Iowa, and at about the same time between Washington and New York. The postal-cars are built and owned by the railway companies, but are, while in use, under the direct control of the government, as represented by its official, the general superintendent of the railway mail service. The fundamental principle of the service is to furnish all towns, both large and small, with rapidly transported mails. Formerly the smaller towns along a railroad received their mail by slow way-trains. But by the device used for exchanging mail bags while the train is in motion, and by the plan of distributing and making up packages of mail on the train itself, time is saved in every way, and the small village is placed on a par with the great city, as respects rapid service.

The American method of exchanging mail-bags differs from the English in several respects. Our postal-car agent throws out on the ground the mail-bag he wishes to leave at a small station, and secures the exchange bag by means of a V-shaped iron hook, or "catcher," attached to the side of the car; this exchange bag, outside, is suspended from the arm of a post near the track in such a manner that it is caught with a vice-like grip in the pinch of the on-rushing V-hook. It requires skill and nice calculation to be able to throw out the bags in a proper manner when the train is moving rapidly. And sometimes a telegraph-pole, a lamp-post, or a switch-light is caught instead of the expected bag. This occurs from



a mistake of the agent as to his exact locality; so, in order that he may be warned in time, the engineer usually blows the whistle in a peculiar manner when nearing a catching station. The American plan of exchanging mails has been copied in Australia and India.

In English mail-cars, the leather bag is fastened by a spring to an iron bar in the car, and when the exchanging station is near at hand the bar is turned out, and the bag hangs suspended like a heavy bait put out to catch fish. At the same time the catching apparatus for securing the return-bag is put out; this consists of a net attached to a bar. In a moment a sharp jerk is heard—the exchange has been effected—one bag drops into the roadside net, and at the same moment other bags come tumbling into the car-net, which is immediately drawn in, and its contents dumped upon the floor, ready to be sorted and pigeon-holed by the busy clerks.

The usual companion of the mail-car, in an American railway train, is the Express-car. The originator of the express business in America was William F. Harnden. He had been an employé of the old Boston and Worcester railroad; but in 1839, being in New York and out of employment, he called for advice upon James W. Hale, who kept a popular reading room in the old Tontine Coffee House, corner of Wall and Pearl streets. Mr. Hale advised him to establish himself as a messenger, or parcel-carrier, between Boston and New York, and suggested the word "Express" as a suitable title for the new business. At that time there were no other means of getting valuable parcels to and fro than by consigning them to the care of some traveller, who was often a complete stranger to the party sending by

•

him. The idea of an express business had suggested itself to Mr. Hale from the circumstance that inquiries were every day made at his reading room for parties going to Boston or Providence, who could be induced to carry parcels. Harnden acted as advised, and advertised himself as an express agent between Boston, Providence and New York. He travelled by the Sound steamers, and for some time a single carpet-bag held all the money and valuables consigned to his care; at the present day the express business surpasses all other private enterprises in the world, with the exception of the railway and the telegraph. Harnden died early, 1845, and was buried in Mt. Auburn Cemetery, near Boston.

A rival of Harnden, from 1840 onwards, was the young Vermonter, Alvin Adams, founder of the Adams Express Company. Most of the wealth of this famous firm was got by business done during the Civil War.\*

A small book might be written on the subject of Railroad Tickets alone. But all that is of popular interest can be told in a couple of pages. Those little pieces of red, yellow, blue, green, chocolate, buff, and pink card-board; and those great white tickets thickly studded with numbers, letters, and quaint designs, and emblazoned with brilliant colors,—did it ever occur to you to estimate the immense number of them that must be used by the railways of the world? Think of the permutations necessary in devising tickets for a road with, say, ninety-eight stations. The agent at each of these stations must be able to furnish

\* Founders of other Express Companies were Henry Wells (at one time an assistant of Harnden) and Wm. G. Fargo. The baggage and transfer business was started in New York city in 1852 by Warren Studley and his brother, to whom succeeded Mr. Dodd. For further particulars of the express business see "Harper's Monthly" for 1875, page 314.

a ticket to every other, and no two tickets must be alike. For ninety-eight stations, then, you must have four thousand four hundred different tickets. Indeed, the number is so great that no conductor ever learns to know them all critically. There are six firms in the United States legitimately engaged in the manufacture of railway tickets; and a single one of these, located in Boston, prints for New England roads seventeen million local tickets in one year, their machine turning out from twelve thousand to thirty-two thousand an hour.\*

In the early days of the railway, no tickets at all were used, the receipt of the booking-clerk serving as evidence of the payment of the fare. The first printed tickets were invented and issued about 1836 by a man named John Edmondson, who was then employed at a little wayside railway station in the neighborhood of Carlisle, England. His printing apparatus was of a very simple and primitive kind, consisting of a few types fastened together in a case about the size of a nail-brush. The name of the station to which the passenger was going was written upon the ticket at the time of its issue. Edmondson found his device a very useful one, and kept inventing new machinery and increasing his business, until it became a great industry, and tickets were printed by his establishment for railways all over the world.† The sons of Edmondson still carry on this immense business at Manchester. The most important stride in advance was made when the tickets were consecutively numbered, for the accuracy of railway accounts depends

\* For many of these facts relating to railway tickets, the author is indebted to Mr. Robert S. Gardiner, of Boston.

† The greater part of French and Spanish railway tickets are printed by De la Rue, of Paris, and Sampson, Low and Company, of London. The great English railways print their own tickets. Mexico, Cuba, and South America get a portion of their tickets in the United States.

on the careful numbering and counting of tickets. Edmondson's perfected steam-power machine was an exceedingly ingenious and delicate little piece of mechanism. He had a small table with a long, thin box rising above it at the back, and another box falling below it in front. The table contained the printing machinery and type-case, while the boxes were for holding tickets, and were just as wide as a ticket. The upper box was filled with a pile of card-board pieces, and one at a time the lowest cards were jerked by a spring under the printing machinery, and then passed to the lower box; the process for each ticket required less than a second of time; all that the attendant had to do was to keep the upper box filled with cards, remove the lower box when filled, supply fresh boxes, pile the finished tickets in rows, and see that the ink reservoir was full. The numbering was done by wheels with raised numerals on their edges; the wheel which had on its edge the first nine numerals moved so that a fresh type was ready for each successive ticket; the wheel in the tens' place at one tenth that rate, and so on. The testing of the tickets for correct numbering was also done by machinery; for the apparatus was so contrived that if the numbering did not go forward in perfect order, a spring was released which rang a bell of warning. The past tense has been used in describing this mechanism, because, although the essential principle of it is still embodied in the machines now used, there have been a great many changes made in the way of improvements.

The first consecutively numbered tickets in America were printed for Sanford, Harroun and Warren, of Buffalo, by George Bailey, who was sent over by Edmondson with one of his machines. This was in 1855. Previous to this, tickets were plain unnumbered pieces of card-board

good for a single passage. As late as 1860 such tickets were used on the Boston and Providence railroad. The cheap-excursion-ticket system was invented by Josiah Perham of Maine, known by his long agitation of the question of a Northern Pacific railroad. One of the curiosities, or mysteries, of the ticket-system is the fact that five per cent of the tickets issued never return to the company issuing them. What becomes of them? Is it possible that so large a number are never used at all?

It remains to speak of coupon-tickets, which are the invention of a gentleman named Hebbard. He was, or is, a civil engineer connected with the United States Navy. The tickets were first used on the Baltimore and Ohio road, and at first excited great opposition and ridicule. But the merriment was ill-timed, for they have now become a necessity as well as a convenience to travellers. In order to prevent the counterfeiting of coupons the best work of the bank-note engraver is called into requisition. This is particularly necessary since coupon-tickets go all over the land, and are handled by sellers and agents far removed from the roads in the combination. The necessity for a coupon-ticket arises from the circumstance that between two distant points there are often several lines of railway. The traveller does not wish to get off the train every six hours, and at any time of day or night, to purchase a new ticket. Hence a combination of roads agree to issue a joint ticket. Where there are fifty or sixty different routes between two great cities it is a difficult science to work out the rates and combinations satisfactorily to all concerned. The shortest line in a combination always fixes the rate, *i.e.*, the longer lines between two points must carry a passenger at the same rate as the shortest one. A semi-annual convention of gen-

eral passenger agents is held for the determining of coupon rates, and a rate-sheet is made out, apportioning to each section of a through route the share decreed it on the division of the money received by the selling road. Each month, tickets and coupons are collected and interchanged, and a balancing of accounts takes place.

The collector of tickets, or the conductor, as he is called in America, is a much abused man, and a much enduring man. There are brutal conductors, and there are gentlemanly conductors, some are hard and unobliging, and others are kind and tender-hearted. Many are profligate, and many are noble in character;—on the whole, a body of men popular, generous, and brave. More kind acts of conductors pass unrecorded than would be imagined. Not long ago as a conductor on a western railroad was standing on the step of one of his cars which was in rapid motion, he saw on the opposite track an old man walking with his back to the Chicago Express which was rushing upon him with lightning speed only a few rods off. It flashed across the mind of the conductor that he could save the old man by jumping so as to hurl himself against him; the thought he embodied in the act, caught the man in his arms, and landed him safely in the ditch, both being by good luck unhurt. This is only one out of many similar acts by conductors. But on the other side we have such experiences as that of Mr. John A. Coleman of Providence, Rhode Island, who was brutally ejected by a conductor from a train on the New York and New Haven railroad, received severe injuries, and, after a long fight of four years in the courts, received three thousand five hundred dollars damages.\* Mr. Cole-

\* He tells his story in a fascinating style in the "Atlantic Monthly" for December, 1872, and May, 1873. ("The Fight of a Man with a Railroad.")

man had a coupon good on its face for a ride from New Haven to New York, and, although having a through ticket in his pocket, he determined to make a test case and see if his ticket were not good from New York to New Haven. The conductor said he had been ordered by his directors not to receive such tickets, and after some debate he and his roughs forcibly ejected Mr. Coleman from the train. During the terrible struggle the flesh was torn from the arm and legs of the resisting passenger, he was ruptured for life, and finally thrown heavily upon his side on the platform. The damages awarded him were for brutal assault, not for the refusal of the road to take the coupon; but the courts have now pretty generally decided that a railway ticket is good either way.

The embezzlements of fares by conductors are enormous; and many railways employ "spotters," or spies, to detect them in their frauds. At one time the New York Central employed women spotters who were furnished with books of instructions, note books, an apparatus of mirrors placed at an angle, and other traps. A set of these implements was captured by the employés of one of the trains, and afforded them much merriment. In 1866, a certain railroad, leading out of Boston, discharged every passenger conductor in its employ, and put on the road new men wholly unused to the work. The next month's receipts showed an addition of thirty-three per cent; and there had been no increase of travel. In January, 1882, seventeen spotters sent out from New York detected many cases of neglect on the part of conductors of western railroads to give rebate checks for cash fares. A rebate check serves as an indication of fare received by conductor, when it is presented at an office for payment. But some of the conductors said the

plan was an imputation on their honesty, and refused to obey orders. The consequence was that one thousand of them were discharged at once by the managers of the several western railroads lying between St. Louis and Denver. In the single year 1863, the conductors of the Philadelphia and Reading railroad embezzled about eighty thousand dollars. After three years' employment of Allan Pinkerton's detective system, the peculations per annum were reduced to about five thousand dollars.

Railways not only suffer from conductors' appropriations, but from the depredations of petty sneak thieves among humbler employés, as well as from the bold robberies of the masked Claude Duvals of the day. In England the open freight cars especially invite pilfering. A few years ago the Midland Railway Company discovered that their trains were being robbed of wine. Casks arriving at the North were found to be broached, and no one knew how it came about. The company determined to conceal spies on one of their wine trains, and see if they could not ferret out the secret. Nothing occurred to excite suspicion until the train reached a certain tunnel at a lonely part of the road. Here the train was stopped, and the engineer, assisted by a signalman, threw back the tarpaulin from one of the freight wagons, broached a cask of wine, drew off a quantity in buckets, and passed it around to all the employés. After a jolly bout by the company, the cloth was replaced and the train steamed onward. Cheeses also seem to offer a peculiar temptation to the English train thief, and many a fat dairy cheese has rolled down into ditch or hedge, whence it could afterward be taken away at night.

A train robbery of a peculiarly dare-devil nature oc-



curred in England not long ago. A noble family leaving London for the east coast had a brass-bound box, containing a selection of plate, placed on the roof of their car and securely covered with tarpaulin. The train was an afternoon express which stopped at only three or four large stations during the whole journey, and arrived at its destination two hours after dark. The box seemed absolutely safe, and no one dreamed of a possible robbery, until when the coast was reached, it was discovered that a goodly portion of the plate had been abstracted. Upon investigation, it appeared that a suspicious-looking character had telegraphed from London in cipher to an individual at a certain way station. When the train arrived at this station, the man who had received the telegram boarded the train, being shown by the guard into an empty compartment. Now, as soon as it was dark, this man must have accomplished the almost incredible feat of traversing the cars between him and the box, while the train was going at the rate of forty miles an hour; then mounted to the roof of the last car, unfastened the tarpaulin, selected the brass-bound box out of twenty or thirty other packages, without exciting the attention of those within the car, forced it open, disposed about his clothing as many pieces of plate as he could carry, refastened the tarpaulin, and retraced his steps safe and undetected to his own car. At the next station he left the train, carrying a bulky portmanteau, and was not heard of more.

At a certain large freight depot in England, a great many articles were at one time missed, chiefly parcels of medium size and weight. One day while walking about the freight-house, intent upon other business, the superintendent noticed that in a certain place some of the boards

that faced the space between the ground and the floor of the platform — a height of about three feet — looked as if they had recently been removed. On trying them he found that they yielded easily, exposing to view the dark cavity within. This he proceeded to explore, crawling in on his hands and knees, and taking a dark lantern with him. Presently he emerged with a grin of satisfaction on his face, remarking to his man that he thought he should catch his thief now. He replaced the planking, and late the same night, unknown to any one but his assistant, entered the cavity, which was so narrow and low that he was obliged to lie at full length. About three or four o'clock in the morning, when the noises of the coming day's labor and traffic were beginning to be heard, he was aware of the sounds of footsteps approaching the spot; his heart beat quick with excitement; the sound of the footsteps ceased opposite his hiding-place; there was a moment's pause and then the boards were pushed aside, and a hand holding a parcel tied up with a string and brown paper was thrust into the hole. There was just light enough from the lamps near at hand for him to see what he was about; he had previously got his handcuffs out, and had fastened one ring of them round one of the iron supports of the platform. "The moment the fellow thrust his hand into the hole," said the superintendent afterward, "I knocked the parcel out of his fingers, grasped him firmly by the wrist, gave him a sudden jerk forward, and before he could say Jack Robinson the other ring of the handcuffs was slipped on to him, and there he was in as nice a little trap as ever I saw." He proved to be a man who came on duty early to help load up market goods. He had generally taken the parcels while the watchman was absent for a moment unlocking the offices, and had hidden

them temporarily under some boxes until he could safely remove them to the hole under the platform.

Another ingenious trick of train-thieves was tried in North Germany, where a railway company had long suffered from depredations without being able to detect the criminal. One day a box labelled, "This Side Up," came into the freight-house; but the employés, disregarding the direction, happened to set it upside down. Some time afterward they were astonished to hear a smothered voice apparently proceeding from the box, and begging those near at hand to let the owner of the voice out. On opening the box — heigho! a man inside standing on his head! When he got on his legs he tried to persuade the officials that his presence in the box was the result of a bet he had made. But the story would not "take," and it was soon discovered that this was the method the thieves had taken to secure their booty. All that the imprisoned man had to do was to let himself out of the box during the absence of the employés, then fill it with whatever he could lay his hands on, fasten down the cover, leave the box to be forwarded to the address marked on it, and then decamp as quickly as possible.

A single specimen of our western train robberies will suffice for hundreds of similar ones. The eastward-bound train on the Missouri Pacific railroad left Otterville, Missouri, a few minutes past ten o'clock on Friday night, July 7, 1876, and when two and a half miles east of that place, the engineer perceived in a deep cut the signal-light for stopping. He applied the air-brakes, and presently saw a pile of ties and timber on the track. At the same moment a dozen masked men dashed up to the train, uttering terrific yells and discharging their pistols. Two of them, jumping on the engine, covered the engineer

and fireman with navy revolvers, and then marched them into the baggage-car, where they were placed under guard. While this was going on, three other robbers had climbed into the express-car; but the express messenger, Bushnell, had already dashed through the train to the sleeping-car in the rear, and made one of the brakemen put the keys of the safe in his boot. Mr. Conkling, the baggage-man of the train, was in the express-car when the robbers entered, and him they marched with a revolver at his head slowly through the train, commanding him to point out the messenger when he saw him. The women and children were in great fear, and many even of the male passengers crouched down behind the seats. When the keys were obtained the Adams safe was opened, and the contents placed in a wheat-sack, which had been brought for the purpose. One of the safes could not be opened with the keys, and one of the villains obtained a pick from the engine-cab and forced open the panel. All this time the rest of the thieves were parading up and down outside of the train, yelling and firing off their revolvers. The passengers were unarmed, and no resistance was made. About sixteen thousand dollars was carried off, and although several parties of men started out in pursuit, the chase was rather a hopeless one.

We have now finished our survey of the railroad system of the world. Much has been left unsaid. We have not considered many of the more conspicuous faults of railroads — the corrupt pass system, dangerous tracks, wretched restaurants, badly ventilated cars,\* arrogance and surli-

\* "Five hundred inches of openings to permit the escape of one and a half million cubic inches of foul air exhaled from the lungs of fifty human beings in one hour!"

ness of officials, unjust rates, cruel combinations against the farmers, discrimination in favor of individuals and monopolizing firms, and the corruption of voters and legislatures. Nor have we entered upon the topic of railway accidents (eight thousand two hundred and fifteen persons either killed or maimed in one year in the United States!). Not that many wonderful and curious things would not have been ploughed up in treating of these themes; but the adequate presentation of them would not only have unduly swelled the proportions of the volume, but would have launched us upon an endless ocean of political and statistical discussion.

What is to be the future of the steam locomotive, it is hard to predict, in view of the possibilities of air-navigation, and the introduction of electric and other motors. But there is no permanent diminution of railway construction; rather an enormous increase, and it is certain that as long as men are obliged to draw heavy loads over rough and muddy ground, a solid rail will be preferred to a rut. It is, therefore, almost certain that the locomotive will go on conquering and to conquer until its sway extends over the three great continents of the globe not yet netted with iron roads. And it is to be hoped that there will be a corresponding increase in safety-devices, and in plans for adding architectural beauty to the railway buildings now so unsightly, as well as landscape adornment to the grounds now so barren of cultivation.

## INDEX.

### A

Accidents and locomotive engineers, 204.  
Accidents, railway, 244.  
Acropolis, the, 90.  
Adams, Charles Francis, Jr., 4 (note), 22 (note), 222.  
Adams, Alvin, 233.  
Adams, William and Company, 146, 147.  
Adhesive power of electric locomotive, 166.  
"Advertiser," the Boston, 59.  
Africa, railroads in, 98-100.  
Albany, 32, 47, 51, 52, 61.  
Albany and Schenectady railroad, 10.  
Aleppo, 116.  
Alexandretta, 116.  
Alleghany Mountains, 127.  
Allen, Horatio, 36, 37, 38, 77.  
Allen, W. F., 88.  
Allier, M., 20.  
Ambulances, railway, 181, 182.  
"American Architect," the, 176.  
American House, Boston, 151.  
"Ampère," the (electric locomotive), 165.  
Apaches, the, 73.  
"Arabian," the, 76, 77.  
Arago, M., 20.  
Archbishop, a French, 16.  
Armored railway train, 187, 188.  
Armstrong, Colonel Geo. B., 231.  
Arth Rigi railway, 130.  
Asleep on an engine, 203.  
Atlanta, Georgia, 118.  
Atlanta and Charlotte Air Line, 122.  
Atlanta campaign, 180, 184.

"Atlantic Monthly," 140, 237 (note).  
Atmospheric railways, 120, 121.  
Automatic signals, 220.  
Ayers, Captain E. A., 229.

### B

Back Bay, Boston, 152.  
Bailey, George, 235.  
Baldwin, Cyrus W., 147.  
Baldwin Locomotive Works, 197.  
Baldwin, W. W., of Philadelphia, 52.  
Balmain's phosphorescent paint, 230.  
Baltimore and Ohio railroad, 33, 39-45, 76, 77.  
Bascom, C. J., 121.  
Bathing cars, 189.  
Bayswater, London, 172.  
Belfast and Northern Counties railroad, 162.  
Bell-rope, the conductor's, 228, 229.  
"Ben. Franklin," the old, 206, 207.  
"Bentley's Miscellany," 25.  
Benton, Thomas H., 68 (note).  
Berlin, 197.  
Berlin Exhibition, electric railroad at, 160.  
"Best Friend," the, 45, 46.  
Betteley, Albert, 147, 148.  
Bicycle railways, 116, 176, 177.  
Birkenhead (England), 172.  
"Bite" of the wheel, 32.  
Blair's Gap, 128.  
Block system, 219, 220.  
Booking passengers, 56.  
"Boston, Memorial History of,"

- 4 (note); and the new time-standard, 89.  
 Boston and Albany (formerly called Boston and Worcester), 57 (note), 59, 60.  
 Boston and Lowell railroad, 10, 58, 59, 60.  
 Boston and Maine railroad, 207, 216.  
 Boston and Providence railroad, 59, 60, 61, 236.  
 Boston and Worcester railroad (see Boston and Albany).  
 Boudoir cars, the Mann, 195.  
 Bound Brook route, 197.  
 Box, man inside a, 242.  
 Brazil, inclined railway in, 132.  
 Breck, Samuel, 22, 189.  
 Brenner railroad, 134-137.  
 "Brigades" of cars, 54.  
 Bristol and Exeter railroad, 202.  
 Brooman, Richard A., 150, 151.  
 Brown, William H., 47.  
 Brunel, I. K., 197.  
 Brunton, William, his locomotive with legs, 8.  
 Bryant, Gridley, 33, 59.  
 Buckingham, Joseph T., 58.  
 Buenos Ayres, 173.  
 Buffalo, New York, 4.  
 Buffer, the first, 50, 51.  
 Bull Run, defeat of, 179.  
 Bull, the, and the engine, 65.  
 Bunker Hill Monument, 33.  
 Burleigh, Charles, of Fitchburg, 138.  
 Burning-glass, 12.  
 Burnt Mill Point, 35.  
 "Burthen" cars, 54.  
 "Busy Bee," the, 202, 203.  
 Bwlfa coal, 112.
- C**
- Cab (of locomotive), 200.  
 Cable railways, 173, 174.  
 Calcutta, 94, 95.  
 Callao, Lima and Oroya railroad, 141.  
 Camborne, 7.  
 Cambridge (Massachusetts), first horse railroad in, 172.  
 "Camel-backs," 199.  
 Canadian Pacific railroad, 73.  
 Capture of a Locomotive, 185-188.  
 Car, first passenger (the "Experiment"), 9; Stephenson's first passenger, 10; the eight-wheeled, 33; with sails, 39, 121, 122; the "Victory," 54; telegraphic, 122, 123; dynograph, 124; bathing, 189; making of a wheel, 225; "Railway Age," 193, 226; postal, 230; express, 232.  
 Carbondale, 125.  
 Cars, luxurious, 191-193; palace and sleeping, 193-195; smoking, 195; Mann boudoir, 195; lighting by electricity, 229, 230; lighting by phosphorescent paint, 230.  
 Caste, 96.  
 Ceniz, Mt., 127; railway, 138.  
 Central Pacific railroad, 71, 72.  
 Central Park, New York city, 174.  
 "Century Magazine," see "Scribner's."  
 Ceylon, 90.  
 Chambers's Journal, 135.  
 Chard and Taunton Railroad Company, 202.  
 Charing Cross Hotel, 152.  
 Charleston and Hamburg railroad, 45-47.  
 Charleston, Massachusetts, 34.  
 Charlottenburg and Spandau electric railroad, 160, 161.  
 Chased by a locomotive, 206, 207.  
 Chat Moss, 19 (note).  
 Chattahoochee, 184.  
 Cheltenham, 8.  
 Chicago, 88; first railroad out of, 70; Railway Exposition at, 75; cable railways in, 173.  
 Chicago Exposition, electric railway at, 164.  
 Chicago, Milwaukee and St. Paul railroad, 69 (note).  
 Childs, Colonel, 193.  
 Chilian laborers, 143.

- China, first and only railroad in, 93.  
 Chinese laborers, 143.  
*Chota-hazare*, the, 95.  
 Cincinnati inclined railways, 131.  
 Cincinnati, Sandusky and Cleveland railroad, 62.  
 Civil war (American), railways in the, 184.  
 Clapham Junction, 223.  
 Clark, John T., 48.  
 Clay, Henry, 62.  
 Clergue, F. H., 132.  
 Clinton, Iowa, 231.  
 Coleman, John A., 237, 238.  
 Coleman, Robert, 118.  
 Cologne, 5.  
 Columbia, Pennsylvania, 127, 128.  
 Conductors, 237, 238.  
 "Consolidations," 199.  
 Cooper, Peter, his first locomotive, 38-45.  
 Coupon tickets, 236, 237.  
 Cox, Jacob D., 184.  
 "Cow-catcher," a novel, 63.  
 Cumberland River, 182.
- D**
- Daft, Leo, 164-167, 173 (note).  
 Darlington, 21; Semi-centennial of the railroad at, 12, 13; Stockton and Darlington railroad, 8-13.  
 Darrell, Nicholas W., 46.  
 Davidson, George, 76.  
 Deadhead, 229.  
 Dearborn, Benjamin, 56, 57.  
 De la Rue, Paris, 234 (note).  
 Delaware and Hudson canal, and the company, 35, 36, 125.  
 Delaware River railway, 86, 87.  
 Denver, 239.  
 Denver and Rio Grande railroad, 74, 141 (note).  
 Depots, railway, 214-216.  
 Deprez, M. Marcel, 159.  
 Despatcher, train, 218, 219.  
 Detmold, C. E., 46.  
 "De Witt Clinton," the old locomotive, 47-51.
- Dickens, Charles, on the English refreshment room, 107, 108; description of Mugby Junction, 215 (note).  
 Dodd, Mr., 233 (note).  
 Dorchester, 59.  
 Double-order system, 219.  
 Dry Dock railway in New York city, 35.  
 Dudley, P. H., 124.  
 Du Moncel, 158.  
 Dymond, Mr. R., 197.  
 Dynograph car, 124.
- E**
- Eads, Captain James B., 119, 120.  
 East Indian railroad, 94, 95.  
 Edison, Thomas Alva, 162-164.  
 Edison's lamps on cars, 230.  
 Eggleston, N. H., 140.  
 Edmonson, John, 234.  
 Eight-wheeled car, 33.  
 Electric air-ship of Tissandier Brothers, 159.  
 Electric railway of Chicago Exposition, 75.  
 "Electric Review," the, 166.  
 Electrical road car, 161.  
 Electricity for lighting cars, 229, 230.  
 Electric signal bells, 229.  
 Electro-magnets, on Daft locomotives, 165, 166, 173 (note).  
 Elephant, the baby, 228.  
 Elevated railways, that of Colonel Stevens, 32; Ohio Railroad Company's, 115, 116; in cities, 174-177.  
 Elevator, passenger, Chapter IX, passim.  
 Ellithorpe, Colonel A. C., 155.  
 Embezzlements of fares, 238.  
 Emmons, Danforth and Scudder, 147.  
 Engine-cleaner, story of the, 202.  
 Engine-cleaners, the, 202.  
 Engineer, life of a locomotive, 203, 204.  
 Engineers, the rival, 28, 29.  
 Englishman, anecdote of the, in  
 Cologne, 45.



English railways, 109-113.  
 Ericsson, 18.  
 Erie railroad, 217, 228, 229.  
 Eugénie, Empress, 190.  
 Evans, Oliver, 30, 31, 57.  
 Excursion ticket, Josiah Perham  
 inventor of, 136.  
 Exhibition, see Exposition.  
 "Experiment," the, 9.  
 Exposition, National, of Rail-  
 way Appliances, 75, 76.  
 Express car system, 232, 233.

## F

Fargo, William G., 233 (note).  
 Favre, Louis, 138.  
 Fields, Mr., 164.  
 Fifth Avenue Hotel, 148.  
 Fight of a man with a railroad,  
 237.  
 Fight for a locomotive, 208-211.  
 Fires, forest and prairie, 79, 80.  
 Fiske, Lieutenant Bradley A.,  
 168.\*  
 Fitchburg, 138.  
 Fitchburg railroad (see Hoosac  
 tunnel), 138-141.  
 Florence, 215.  
 Fluid-retarder, 150.  
 "Flying Dutchman," the, 46,  
 197.  
 Flying locomotive, 121.  
 Forest Fires, 79, 80.  
 Foster, Raswick and Company, of  
 Stourbridge, 36.  
 Fox, Charles, 18.  
 France, railway travel in, 107,  
 108; no military railway organ-  
 ization in, 182, 183.  
 Francis's "History of Railways,"  
 23.  
 Franco-Prussian War, 179-183.  
 Frankfort, 62, 63, 64.  
 Freight cars, early, 54.  
 Funicular counterpoise railways,  
 130, 131.

## G

Galloway, Tom., 77.  
 Gardiner, Robert S., 234 (note).

Gauges, 213, 214.  
 Georgia campaign, 180.  
 Germans, the, and their railways  
 in war, 180-184.  
 Germany, railways in, 104-106.  
 Giant's Causeway, 162.  
 Giessbach, railroad on the, 131.  
 Gillis, Judge J. L., 48-51.  
 Glasgow, 8, 24.  
 Gloucester, 8; New Jersey, 118.  
 Grand Cañon of the Arkansas,  
 74.  
 Grand Central Depot, 221-  
 Grand Junction railway, 217.  
 Granite railway, old, 33-35, 57,  
 59.  
 Grasshopper engines, 6.  
 Gray, Thomas, 14.  
 Gravity railroad, the, of Mauch  
 Chunk, 35.  
 Great Wabash railroad, 64-66.  
 Great Western railroad (England),  
 197.  
 Green Mountain inclined rail-  
 way (Mt. Desert), 131, 132.  
 Greenville, New Jersey, 164.  
 Gregori, M. Louis, 183 (note).  
 "Grip and Go," 199.  
 Gunnison, Black Cañon of the,  
 75.  
 Gurney, Goldsworthy, 8.

## H

Hadrian's Villa, 90.  
 Hailstorm, wonderful, 80-82.  
 Hale, Edward Everett, 57 (note).  
 Hale, James W., 232.  
 Hale, Nathan, 57, 58.  
 Hambright, William, 228.  
 Hamilton, Gail, 68 (note).  
 Hamley, Colonel, 179.  
 Harlem railroad corporation, 171.  
 Harnden, William F., 232.  
 Harper and Brothers, 146 (text  
 and note).  
 "Harper's Monthly Magazine,"  
 145 (note), 185 (note), 233 (note).  
 "Harper's Weekly," 166 (note).  
 Harvard Observatory, 89.  
 Harvey, Charles T., 175.

Hawk, story of the, and the locomotive smoke, 200.  
 Haywood, Mr. Percival, 119.  
 Hecker, Mr., 146.  
 "Herald," the Boston Sunday, 40 (note).  
 Herbert, Sir Henry, 16.  
 Hindley, Charles, 32.  
 Hitchcock, Hiram, 149.  
 "Hole in the Wall," 221.  
 Hollidaysburg, Pennsylvania, 128.  
 Holyhead, Wales, 203.  
 Hone, Philip, 36.  
 Honesdale, 35, 36.  
 Honesdale and Carbondale railroad, 35-38.  
 Hoosac Tunnel railway, 138-141.  
 Hornell, New York, 228.  
 Horse-power car, 39.  
 Horse railroads (see Street railroads).  
 Hudson, George, 28, 29.  
 Hugo, Victor, 2.  
 Huskisson, Mr., 18.  
 Hydraulic elevators, 152-154.

## I

Inclined railways, 52, 64.  
 Indiana, Bloomington and Western railroad, 62.  
 India, railways in, 94-98.  
 Indians, the, of North America; their attacks on railroads, 77-79; as railroad-hands, 78.  
 Interlocking towers, cabins, and switches, 221-223.  
 Isthmus of Tehuantepec, 119.  
 Italian war, railways utilized in, 180.

## J

Jacksonville, Illinois, 66.  
 Japan, railroads in, 91-93.  
 Jervis, John B., 36, 200.  
 Johnstown, Pennsylvania, 128.  
 Joinville, Prince de, 149.  
 Juniata, 128.

## K

Kansas Pacific railroad, 121, 123, 228.

Kemble, Mrs. Frances, 19 (note).  
 Kendall, Amos A., 230.  
 Kentucky, first railroad in, 62, 64.  
 Kentucky River, the, 62.  
 Kerosene, for oiling track, 206.  
 Kiowa, Kansas, 80.  
 Krudener, Baron, 39.

## L

Lackawaxen River, 37.  
 Lake Erie, 32.  
 Lancaster, Pennsylvania, 228.  
 Land and Pritchett, Messrs., 116.  
 Land-grant, the first railway, 70.  
 Land-slide on Central Pacific, 72.  
 Langham Hotel, 152.  
 Latrobe, H. H., 43.  
 Lexington, Kentucky, 62, 63.  
 Lexington, Kentucky, railroad, 62-64.  
 Lichterfelde, 161.  
 Light, Charles L., 172.  
 Lighting cars by electricity and phosphorescent paint, 230.  
 Lincoln, President, 186.  
 "Lippincott's Magazine," 206.  
 Liverpool, 14.  
 Liverpool and Manchester railroad, 14-19, 21.  
 Locomotive, first steam, 6; huge one for Southern Pacific road, 76; landed in Ceylon, 90; on sled-runners, 114, 115; two-wheeled, 118; flying, 121; the "Ampère," 165; capture of a, 185-188; general features of the, Chapter XIII; appetite of, 201; straw-burning and petroleum-burning, 200; average life of, 201; repairing, 201, 202; engineer, 203, 204; chased by a, 206; a runaway, 207; fight for a, 208-211.  
 Locomotives, road, 7, 8; features of early (driving-wheels, headlight, etc.), 54; quaint early, 76, 77; electric, Chapter X, passim; English, 199; American, 199, 200.  
 Logging railway, 117.

London, England, 25; underground railway in, 111-113; railroad viaducts in, 174, 175; electric railways in, 166, 167; interlocking switch system of, 221-223.  
 London and Brighton railroad, 230.  
 Lofbat, M., 171, 172.  
 Lowell, Massachusetts, 207.  
 Lowell and Nashua railroad, 217, 218.  
 Lunches eaten in cars, 106, 108.  
 Lyons, France, cable railways of, 131.

## M

MacMahon, 179.  
 Mad River and Lake Erie railroad, the, 62.  
 Maidstone, England, 8.  
 Manassas railroad, 179.  
 Manchester, 15, 24.  
 Manhattan Elevated Railroad Company, 174, 176.  
 Manias railway, 23-30.  
 Mann boudoir cars, 195.  
 Marchioness, the, 26-28.  
 Marie Louise, 190.  
 Marine railway, 119, 120.  
 Marsh, Sylvester, 129.  
 Massachusetts, early railroads in, 56-61.  
 Massachusetts Electric Power Company, 165.  
 Massachusetts, whimsical report of the House of Representatives of, 176.  
 Matthews, David, 77.  
 Mauch Chunk gravity railroad, 126.  
 Medhurst, 120.  
 Meiggs, Henry, 141, 142.  
 Menlo Park, New Jersey, 162.  
 Meredosa, 64, 65.  
 Merrimack River, 57.  
 Merryweather, locomotive maker, 173.  
 Mesgriny, 200.  
 Metucher, 164.  
 Metz, 183.

Mexican Central railroad, 73, 74.  
 Michigan Central railroad, 66, 67; train lost on, 84.  
 Michigan Southern railroad, 84.  
 Middlesex canal, 57.  
 Midland railway, 239.  
 Milan, 215.  
 Miller coupler, buffer, and platform, 226, 227.  
 Minot, Charles, 217.  
*Mish-Mish*, the, 99.  
 Missouri Pacific railway, robbery of train on the, 242, 243.  
 Mitchell, John, 230.  
 Mobile and Ohio railroad, 70.  
 "Moguls," 199.  
 Mohawk and Hudson railroad, 47, 52.  
 Monitor car, the first, 54.  
 Monotony, Kansas, 80.  
 Montgomery, J. E., 143.  
 Moore and Wyman, 151.  
 Moore, Tom, 126.  
 Moosic Mountains, 125.  
 Morris, Gouverneur K., 32.  
 Motoneer, the, 166.  
 Movable truck, 33.  
 Mt. Cenis (see Cenis).  
 Mt. Desert railway, 131, 132.  
 Mt. Washington railway, New Hampshire, 129, 130.  
 Mugby Junction, 215 (note).  
 Mules, riding on cars, 35.  
 Mummies, 201.  
 Murdock, his first engine, 6.  
 Mushrooms, stopping of a train by, 198.

## N

Nantygolyn, 208.  
 Napoleon Bonaparte, 180, 189, 190.  
 Napoleon III, 190, 191.  
 Narrow gauge roads, 214.  
 Nazareth, change cars for, 90.  
 Neponset River, 34.  
 New York, 4, 221.  
 New York and Brooklyn bridge, cable railroad over, 173, 174.  
 New York and Chicago Limited, 198.

- New York and Harlem railroad, 10, 169-171.  
 New York Central railroad, 52, 69, 238; sleeping cars on, 194.  
 New York Elevated Railroad Company, 175 (compare elevated railroads).  
 North-eastern Railway Company of England, 76.  
 Northern Cross railroad, 64.  
 Northern Pacific railroad, 73, 236.  
 Norway, railways in, 102.  
 "Notes and Queries," 197.  
 "Novelty," 18.
- O
- Ohio, 62.  
 "Old Ironsides," 52-54.  
 Otis Brothers, 154.  
 Otis, E. G., 146.  
 "Owd Neddy," 8.
- P
- Page, Professor C. G., 159, 160.  
 Paine, Colonel William H., 174.  
 Paisley, 8, 24.  
 Palais de l'Industrie, 161.  
 Pân, 95.  
 Papin, of Blois, 120.  
 Paris Exposition (1878), 152.  
 Paris Exposition (1881), 161.  
 Parker House, Boston, accident at, 155.  
 Passy, M., 20.  
 Paterson, New Jersey, 62.  
 Pease, Edward ("Owd Neddy"), 8.  
 Pennsylvania Central railroad, 69, 164, 175, 179 (note), 197, 220, 228; mountain division, 129; history of, by Dredge, 129 (note).  
 Pennsylvania Coal Company, 126.  
 Pennsylvania, first railroad-train in, 52-54.  
 "Pennsylvania Magazine of History and Biography," 129 (note).  
 Perdonnet, M. Auguste, 19.  
 Perkins, Thomas Handasyd, 33.  
 "Perseverance," the, 18.  
 Peru, 141.
- Petroleum for locomotives, 200.  
 Phelps, Dr. Abner, 57.  
 Philadelphia, 127, 228.  
 Philadelphia, Germantown and Norristown railroad, 52.  
 Philadelphia and Reading railroad, 54, 56, 239.  
 Phoenixville, Pennsylvania, 56, 118.  
 Phosphorescent paint, 230.  
 Pilfering from railways, 239-243.  
 Pinkerton, Allan, 239.  
 Pinkus, 121.  
 Piraeus, 90.  
 Pittenger, Rev. William, 185 (note).  
 Pittsburgh, 127, exposition of, in 1883, 77.  
 Plate, stolen, 240.  
 Plymouth, 7.  
 "Popular Science Monthly," 169.  
 Portage railroad, 127-129.  
 Port Rush, 162.  
 Postal-car system, 230-232.  
 Proa, the Indian, 32.  
 "Puffing Billy," the, 76.  
 Pullman car, lighted by electricity, 230.  
 Pullman Car Company, 194, 195.  
 Pullman, George M., 194.
- R
- Rail, manufacture of a, 112, 113.  
 Railroad (see Railway).  
 Rails, strap or slab, 54-56; grooved, 171; step, 171.  
 Railway (see names of special railways elsewhere in the index), draught-power of, 4; functions of, 4; early objections to the, 15-17, 21-23, 58, 59; objections to by the negroes, 63; first French, 20, 21; manias, 23-30; submarine, 119; among the clouds, 141.  
 "Railway Age," the, 77 (note).  
 "Railway Age" car, the, 193; wheels of, 226.  
 "Railway Review," 132 (note).  
 Railways, miles built in United States in 1882, 3; fixtures and

- features of early English roads, 12; first American, Chapter III; on the ice, 115; in the tree-tops, 115; elevated—that of Colonel Stevens's, 32; Ohio Railroad Company's, 115, 116; in cities, 174-177; wooden, 116; bicycle, 116, 176, 177; toy, 118, 119; submarine, 119; atmospheric, 120; marine, 119, 120; mountain, Chapter VIII; gravity, 35, 125-127; funicular counterpoise, 130, 131; electric, 158-169; street, 168-177; cable street, 173, 174; and war-hospitals, 181; and ambulances, 181.
- Rainhill, 17, 18.
- Rebate checks, 238, 239.
- Rodruth, in Cornwall, 6.
- Report of Massachusetts Representatives on an early railway plan, 176, 177.
- Reuter, Baron, 90.
- "Revue des Deux Mondes," the, 183 (note).
- Rigi (see Vaudois and Arth).
- Rigi-Kulm railway, 130.
- Riggenbach, Herr, 130.
- Riots, railroad, 178.
- Robber on English train, 109.
- Roberts, Solomon W., 129 (note).
- Rochester, 61.
- "Rocket," the, 18.
- Rogers, Grosvenor, and Ketchum, 62, 65.
- Romilly, 200.
- Rope, the conductor's, 228, 229.
- Royal Gorge, the, 74, 75.
- Ruskin, 3, 16.
- Russell, F. Scott, 199.
- Russia, railways in, 101, 102.
- S**
- Sailing car, 39; on the Kansas Pacific railroad, 121.
- "Sampson," the, 76.
- Sampson, Low and Company, 234 (note).
- Sand-fence, 73.
- Sandusky, 62.
- Sanford, Harroun and Warren, 235.
- San Francisco, cable roads in, 173.
- San Paulo railroad, 95 (note).
- "Sanspareil," the, 18.
- Saratoga, Mt. McGregor and Lake George railroad, 165.
- Schenectady, 47, 48, 51, 52.
- "Science," 77 (note), 132, 159.
- "Scientific American," the, 114, 123, 187.
- Scranton, Pennsylvania, 126.
- "Scribner's Monthly," 143.
- Scudder, Samuel H., 77 (note).
- Seeds, Joseph A. (engineer), 204, 205.
- Semaphore, the, 220.
- Semmering railway, 134.
- Semples, General, 66.
- Shah, the, 90.
- Sharon, Senator, 191, 192.
- Sheer Ali, 3.
- Sherman, General, and the railways, 180, 184.
- Shipton, Mother, 31, 32.
- Signals, 216-218, 229; early night, 12; candle, 12; automatic, 220; electric, 229.
- Siemens and Halske, 160, 161.
- Siemens, Messrs., 162, 168.
- Siemens, Professor Werner, 159, 161.
- Silhouette-artist Brown, 47, 48.
- Sleeping cars, invention of, 193, 194.
- Slough, 197.
- Smalley, E. V., 73.
- Smith, Sydney, 1.
- Smoking cars, 195.
- "Snake-heads," 56.
- Snow plough on Quincy railroad, 34.
- Snow ploughs, evidently no, 65; in the West, 82, 83.
- Snow-storms, trains lost in, 83-87.
- Snow's "Geography of Boston," 35 (note).
- Soissons, 230.
- South Carolina, 45, 122.

- South Carolina Central railroad, 116-118.  
 Southeastern railway, 229.  
 Southern Pacific railroad, 69, 72, 73.  
 Spain, travel by rail in, 106, 107.  
 Speed, 16, 17, 32, 63, 196-198.  
 "Spitzbergen and Patagonia," 25.  
 Spotters, 238.  
 Springfield, Illinois, 64.  
 St. Germain railway, 20, 21.  
 St. Gothard railway, 137, 138.  
 St. Petersburg, 197.  
 Staff and ticket system, 221.  
 Stage-horses, over-driving of, 15, 51.  
 Stage travel, 51.  
 Standard time, 87, 89.  
 Stations, railway, 214-216.  
 "Staym-inges," 199.  
 "Steam caravan" railroad, 116-118.  
 Steam-whistle, 62.  
 Stephenson, George, 8, 10; before the Parliament Committee, 17; at Rainhill, 17, 18; talk with Mrs. Kemble, 19 (note).  
 Stephenson, John, 169, 170.  
 Stephenson locomotive (in America), 60.  
 Stevens, Colonel John, 32, 33.  
 Stevens, Paran, 149.  
 Stevens, William, and his midnight ride, 202, 203.  
 Stillman, W. J., 223.  
 Stevenson, David, 127.  
 Stockton and Darlington railway, 76.  
 Stockton and Stokes, 44.  
 Stone, General LeRoy, 118.  
 "Stourbridge Lion," the, 36-38.  
 "Strap" rails, 54, 56.  
 Street railroads, 169-177; electric, 168; ordinary, 169-174; elevated, 174-177; in Paris, 172; in England, 172; in various countries, 173.  
 Studley, Warren, 233 (note).  
 Submarine railway, 119.  
 Susquehanna, 128.  
 Sweden, Du Chaillu's account of railway restaurant in, 103, 104.  
 Swinburne, William, 62.  
 Switchback railroad, 126, 127.
- T
- Talbot, E. H., 10, 77 (note), 193.  
 Tathams, the, 146.  
 Taylor, Benjamin F., 71 (note), 212.  
 Tehacape Pass, 73.  
 Telegraph poles, made of iron rails, 95 (note).  
 Telegraphic car, 122.  
 Telescopic hydraulic elevators, 153.  
 "Tenderfoot," the story about, 79.  
 Tender (of locomotive), 63.  
 Tennessee campaigns, 181, 182.  
 Terre Haute, Alton and St. Louis railway, 193.  
 Tewksbury, Massachusetts, 207.  
 Thackeray, 28 (note).  
 Thiers, M., 20.  
 Thomas, Evan, 39.  
 Thorp and Sprague, 50.  
 Tickets, railway, 233-237.  
 Time, standard, 87-89.  
 "Times," the London, 4.  
 "Times," the New York, 229.  
 Tissandier, Gaston, 159.  
 Tivoli, 90.  
 "Tom Thumb," the, 39-45.  
 Tornadoes, 80, 81.  
 Train, George Francis, 172, 173.  
 Train, New York and Chicago Limited, 197; stopping a, by mushrooms, 198; despatcher, 218, 219; staff and ticket system, 221.  
 Train, lost in quicksand, etc., 80; lost in snow storms, 83-87.  
 Tramways (see Street railroads).  
 Trevithick, Richard, anecdote of his road locomotive, 7.  
 "Tribune," the New York, 166, 205.  
 Troy and Greenfield railway, 138.  
 Truck of American locomotive, 200.  
 Trunk lines, definition of, 68;

formation of, 69; early western, 69.  
 Tufts, Otis, 146, 148-151.  
 Tunnel, the first railroad tunnel in America, 128; the St. Gothard, 137.  
 Turk, the imperturbable old, 99.  
 Tussaud, Madame, 190.  
 Two-wheeled locomotive, 118.

## U

Uetliberg railroad, 131.  
 Underground railways of London, etc., 111-113.  
 Union Pacific railroad, 70-72, 78, 81, 83.

## V

Vanderbilt, President W. H., car of, 192.  
 Vaudois Rigi railroad, 130, 131.  
 Velocipedes, railway, 118.  
 Ventilation of cars, 243 (note).  
 Verviers, 215.  
 Vesuvius, Mt., railway of, 132, 133.  
 Viaducts, railroad, 174, 175.  
 "Victory," the car, 54.  
 Victoria, Queen, travelling of, 191.  
 Vitznau, 130.  
 Von Moltke, General, 183.

## W

Wabash railroad, 64-66.  
 Wagner, Webster, 194.  
 Wales, Prince of, 149.  
 Wales, South, 198.

Washburn, William, 149.  
 Waterloo, 181.  
 Waterman, Henry, 146.  
 Waterspouts, 80.  
 Wellington, Duke of, 18, 19.  
 Weller, Tony, 2.  
 Wells, Henry, 233 (note).  
 West Point Foundry, 36, 45.  
 "West Point," the, 46, 47.  
 Western railroad, ceremonies attending the opening of, 61.  
 Westinghouse brakes, 193, 227, 228.  
 Wheel, manufacture of a, 225, 226.  
 Whitehead, Joseph, 77.  
 Whitman, Walt, 3, 74.  
 Whittier, Charles, 146 (note).  
 Wilkins, Bishop, 121.  
 Williams, Captain C. W., 122.  
 Winans, Ross, 33.  
 Winslow, J. B., 10.  
 Woman and electricity, 158.  
 Women in railway speculation, 25-28.  
 Wooden railways, 116.  
 Woodruff, inventor of sleeping car, 193, 194.  
 Worcester, 59, 60.  
 Wordsworth, the poet, 16.  
 Wurtz, William and Maurice, 125.

## Y

Yarns, curious railway (in the West), 205.

## Z

Zanckerode electric railway, 161.

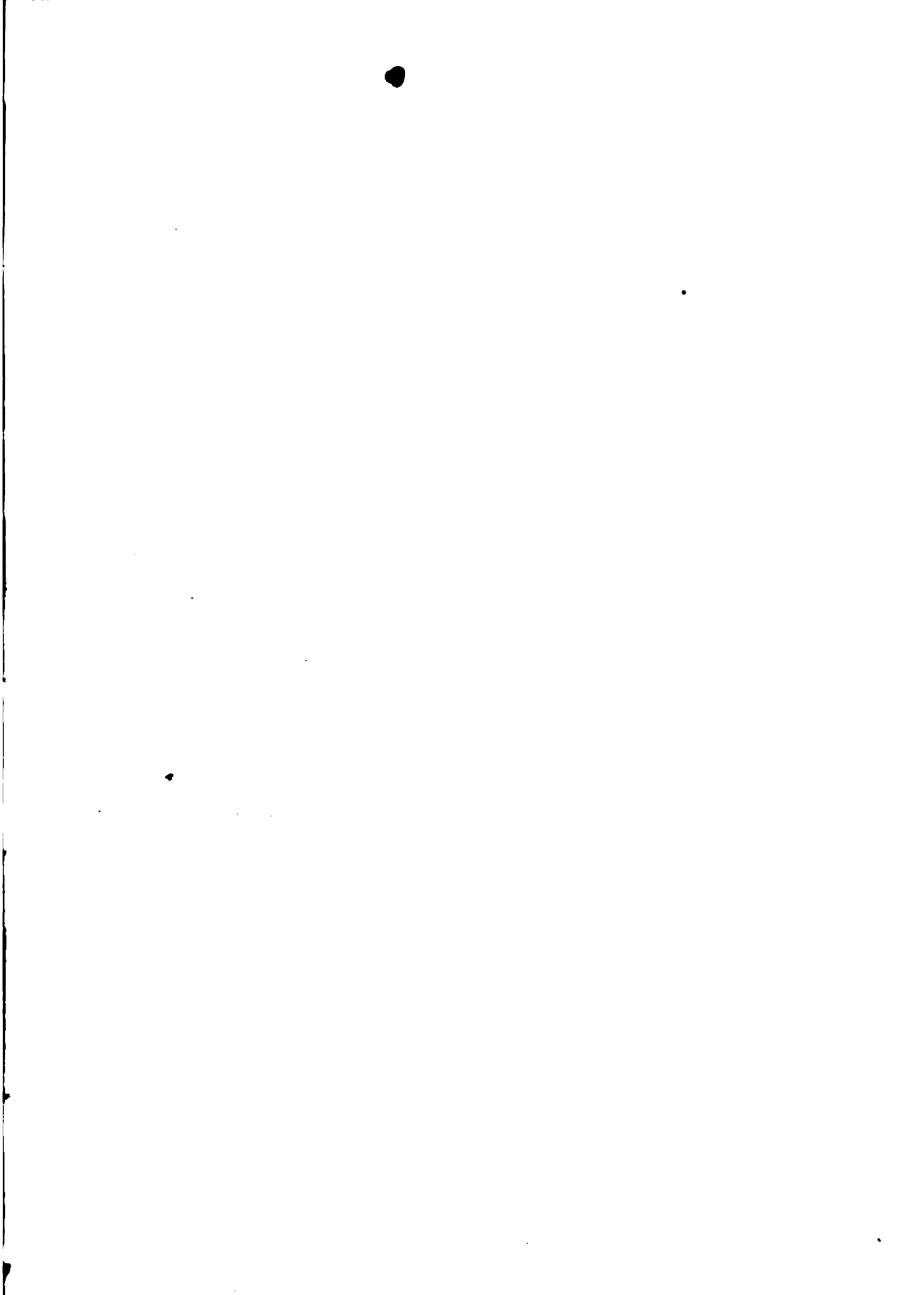





A PARTIAL LIST  
OF THE  
PUBLICATIONS  
OF  
S. C. GRIGGS AND COMPANY,  
CHICAGO.

---

**Anderson—America Not Discovered by Columbus.** A historical Sketch of the Discovery of America by the Norsemen in the 10th century. By R. B. ANDERSON. Also a Bibliography of the Pre-Columbian Discoveries of America. By PAUL BARON WATSON. 12mo, cloth, \$1.

"A valuable addition to American history."—*Notes and Queries*, London.

**Anderson—Norse Mythology; or, the Religion of our Forefathers.** Containing all the Myths of the Eddas carefully systematized and interpreted; with an Introduction, Vocabulary, and Index. By R. B. ANDERSON, Prof. of Scandinavian Languages, Univ. of Wisconsin. Crown 8vo, cloth, \$2.50; half calf, \$4.

"Prof. Anderson's work is incomparably superior to the already existing books of this order."—*Scribner's Monthly*.

"The exposition, analysis and interpretation of the Norse Mythology leave nothing to be desired."—*Appleton's Journal*.

**Anderson—Viking Tales of the North.** The Sagas of Thorstein, Viking's Son and Fridthjof the Bold. Translated from the Icelandic by Prof. R. B. ANDERSON; also TEGNER'S FRIDTHJOF'S SAGA, translated by GEO. STEPHENS. One vol. Cloth, \$2.

"Prof. Anderson's book is a very valuable and important one."—*Nation*.

"A charming book it is. Your work is in every way cleverly done. These quaintly delightful sagas ought to charm many thousands of readers, and your translation is of the best."—*Prof. Willard Fiske, Cornell University*.

**Anderson—The Younger Edda,**—also called Snorre's Edda, or the Prose Edda. With an Introduction, Notes, Vocabulary and Index. By Prof. R. B. ANDERSON. Crown 8vo, cloth, \$2.

"The most complete and literally faithful English version yet produced of Snorre's Edda."—*The Scotsman*, Edinburgh, Scotland.

**Bacon—A Manual of Gesture.** With 100 Figures, embracing a complete System of Notation, with the Principles of Interpretation, and Selections for Practice. By A. M. BACON. \$1.50.

"The work comprehends all that is valuable on the subject of gesture."—*R. L. Cumnock, Prof. of Elocution, Northwestern University*.

 Books will be mailed, post-paid, on receipt of price.

**Barbou—Victor Hugo; His Life and Works.** From the French of Alfred Barbou, by Miss F. A. SHAW. With Portraits. 16mo, cloth, \$1.

"Filled with delightful personal details."—*Gazette*, Baltimore.

**Blanc—The Grammar of Painting and Engraving.** Translated from the French of Charles Blanc by Mrs. KATE N. DOGGETT. With the original illustrations. 8vo, cloth, \$3.

"We know of no other work which can quite take its place in the hands of those who, without any artistic training, desire to acquire clear ideas concerning the elementary principles of art."—*Appleton's Journal*.

**Bredif—Demosthenes—Political Eloquence in Greece.**

With extracts from his orations, and a critical discussion of the "Trial on the Crown." From the French of L. BREDIF, of the University of France, by M. J. MACMAHON, A.M. 8vo, cloth, gilt top, \$2.50

"The result of no less than twenty-two years' hard study of Greek literature, and especially of Demosthenes and his eloquence. . . . This work on the illustrious Greek orator ought to be in the hands of all *preachers, lecturers, actors* and *politicians*. Mr. MacMahon's translation of this remarkable book is admirable."—*London Morning Post*, England.

**Brown—Wit and Humor.** A choice collection. By MARSHALL BROWN. 12mo, cloth, \$1.

"There is an enormous amount of laughter in the pages of this book."—*Evening Mail*, New York.

**Carew—Tangled.** A Novel. By RACHEL CAREW. Cloth, \$1.

"Full of the most amusing incidents. . . . The book will amply repay reading. . . . It is, in fact, a happy idea and a capital performance."—*The Churchman*, N. Y.

**Cone—Two Years in California.** By M. CONE. With 15 Illustrations, map of California, and plan of the Yosemite. Clo., \$1.50.

"It abounds in information practical in character, and is stored with facts which will be new to the vast majority of our people."—*Eve. Journal*, Albany.

**Cross—Eclectic Short-Hand Primer.** Four Lessons Introductory to "Eclectic Short-Hand." By J. GEO. CROSS. Flexible, 25 cents.

**Cross—Eclectic Short-Hand.** For general use and verbatim reporting. By J. G. CROSS, A.M. 12mo, cloth, \$2.

"It is true that it makes verbatim reporters in less than half the time required by the best of the other systems. It is very easy to learn, very easy to write, unincumbered by word-signs, exceedingly brief, and yet legible as long-hand."—*George Yeager, A.M., Pres. of Phila. College of Short-Hand*.

**Fawcett—Hand-Book of Finance.** With over 80 Tables and Diagrams. By W. L. FAWCETT. 12mo, cloth, \$1.75.

"As a full and very complete collection of monetary statistics it has never been equalled or even approached. A storehouse of facts."—*Press*, Phila.

**Forestier—Echoes from Mist-Land; or, the Nibelungen Lay revealed to Lovers of Romance and Chivalry.** By AUBER FORESTIER. 12mo, cloth, \$1.50.

"The simplicity and directness of the ancient chronicle are admirably preserved in the version, and the work forms a unique addition to our store of sterling fiction."—*Home Journal*, New York.

**Foster—Pre-historic Races of the United States.** By J. W. FOSTER, LL.D. Illustrated. Crown 8vo, cloth, \$3; half calf, gilt top, \$5; full calf, gilt edges, \$6.50.

"It is full of interest from beginning to end."—*Popular Science Monthly*.

"Literally crowded with astonishing and valuable facts."—*Post*, Boston.

"One of the best and clearest accounts we have seen of those grand monuments of a forgotten race."—*The Saturday Review*, London.

**Griggs's Philosophical Classics.** Under the editorial supervision of GEORGE S. MORRIS, Ph. D., Prof. of Ethics, History of Philosophy and Logic in the University of Michigan, and Lecturer on Philosophy in the Johns Hopkins University.

**I. Kant's Critique of Pure Reason; A Critical Exposition.** By GEORGE S. MORRIS, Ph.D. 16mo, cloth, \$1.25.

"A book like this is almost indispensable to the average student of Kant."—*The Nation*.

"An extremely interesting book. . . . An Exposition of the Critique that is sympathetic, just, clear, suggestive, fascinating."—*Tribune*, New York.

**II. Schelling's Transcendental Idealism.** By Prof. JOHN WATSON, of Queen's University. In uniform style, \$1.25.

"The best hand-book on its subject in the language, and deserves a wide reading."—*Unitarian Review*, Boston.

"The studious and intelligent reader of Professor Watson's well-digested and very able treatise, will derive therefrom a clearer and more adequate idea of Schelling's philosophy than he could hope to obtain from an unassisted study of the original."—*North American*, Philadelphia.

Other volumes in preparation by Pres. PORTER, Prof. ROBERT ADAMSON, Dr. WM. T. HARRIS, Prof. J. S. KEDNEY, Dr. A. M. FAIRBAIRN, Dr. EVERETT, and Prof. HOWISON.

**Hall—Lyrics of Home-Land.** By EUGENE J. HALL. Uniform in size and style with Taylor's "Songs of Yesterday." Profusely and elegantly illustrated. Full gilt, \$3.

"Literature and art have seldom been more happily combined."—*Gazette*, Cincinnati.

**Holcomb—Fridthjof's Saga.** A Norse Romance. By ESAIAS TEGNER, Bishop of Wexio. Translated from the Swedish by T. A. E. and MARTHA A. LYON HOLCOMB. 12mo, cloth, \$1.50.

"No one can peruse this noble poem without arising therefrom with a loftier idea of human bravery and a better conception of human love."—*Inter Ocean*, Chicago.

"Tegner's Fridthjof's Saga is one of the most remarkable productions of the age."—*North American Review*.

**Hudson—Law for the Clergy.** Relating to the duties of Clergymen in the solemnization of Marriage, the organization of Churches and Religious Societies, and the protection of Religious Assemblies; embracing a collation of the Common Law of Marriage. By S. A. HUDSON. 16mo, cloth, \$1.

"It contains what every preacher should have. It is a safe guide in securing deeds and titles to property, to churches, etc."—*Religious Telescope*, Dayton.

**Janson—The Spell-Bound Fiddler.** A Norse Romance. By KRISTOPHER JANSON. Translated by AUBER FORESTIER. With an introduction by R. B. ANDERSON. 12mo, cloth, \$1.

"A brilliant romance."—*Evening Traveller*, Boston.

**Lie—The Pilot and His Wife.** A Norse Love Story. By JONAS LIE. Translated by Mrs. OLE BULL. Cloth, \$1.50.

"Most absorbingly interesting. . . . In realism, picturesqueness and psychological insight, 'The Pilot and His Wife' leaves very little to be desired."—*Scribner's Monthly*.

**Lie—The Barque Future.** By JONAS LIE. Translated by Mrs. OLE BULL. 12mo, cloth, \$1.

"Its pictures of life in the far north—the fishermen of Norway, the lonely trading ports on the Fjord, the habits of the people—are full of a simple and rare beauty. The impression which the book makes is altogether delightful, and we commend it to our readers in the strongest terms."—*Lit. World*, Boston.

**Lorimer—Isms, Old and New.** By GEORGE C. LORIMER, D.D. 12mo, cloth, \$1.50.

"Written in a style remarkable for its freshness and force, its ornate elegance and its popular attractiveness, and every page glistens with apt quotation, and shows large reading and earnest thinking. They meet actual foes of evangelical Christianity face to face with facts and arguments which cannot be gainsaid or answered."—*Evangelist*, New York.

**Maertz—A New Method for the Study of English Literature.** By LOUISE MAERTZ, Flexible, interleaved, \$1.

"It consists of a series of questions on English and Continental Literature and contemporaneous events, with references to a well selected list of books from which the answers may be drawn. The plan is a good one, especially for training students to look up matters for themselves and to put the results into concise form."—*Literary World*, Boston.

**Mathews — Getting on in the World; or, Hints on Success in Life.** By WM. MATHEWS, LL.D. 12mo, cloth, \$1.50; cloth, gilt edges, \$2; half calf, gilt top, \$3.50; full calf, gilt edges, \$5.

"It is a book of facts and not of theories. The men who have succeeded in life are laid under tribute and made to divulge the secret of their success. They give vastly more than 'hints'—they make revelation."—*Christian Era*, Boston.

**Mathews — The Great Conversers, and Other Essays.** By WILLIAM MATHEWS, LL.D. 12mo, cloth, \$1.50.

"One will make the acquaintance of more authors in the course of a single one of his essays than are probably to be met with in the same limited space anywhere else in the whole realm of our literature."—*Tribune*, Chicago.

**Mathews — Words, Their Use and Abuse.** By WILLIAM MATHEWS, LL.D. 12mo, cloth, \$2.00.

"We heartily recommend it as rich in valuable suggestions to those who desire to cultivate accuracy in speaking and writing."—*Lutheran Review*

**Mathews — Hours with Men and Books.** By WILLIAM MATHEWS, LL.D. 12mo, cloth, \$1.50.

"A storehouse of valuable information."—*London Morning Post*, England.

**Mathews — Monday-Chats.** By C. A. SAINTE-BEUVE. With an Introductory Essay on his life and writings by the translator, WILLIAM MATHEWS, LL.D. 12mo, cloth, \$2.

"Sainte-Beuve, the finest critical spirit of our time."—*Matthew Arnold*.

This volume contains "literary portraits worked out in the most delicate and careful manner" of Louis the Fourteenth, Fenelon, Bossuet, Massillon, Pascal, Rousseau, Madame Geoffrin, Joubert, Guizot, The Abbe Galiani, and Frederick the Great.

"Such admirable biographical essays in so small a compass are nowhere else to be found. They are miniatures of the most excellent workmanship."—*Edinburgh Review*.

**Mathews — Oratory and Orators.** By WILLIAM MATHEWS, LL.D. Cloth, 12mo, \$2; half calf, \$3.50; full calf, \$5.

"A mine of wealth, full of practical suggestions and information. Besides the value of the directions to a public speaker, the book abounds with sparkling anecdotes and gems of thought of celebrated authors."—*Record*, Phila.

"A book of remarkable interest, as valuable for its sound criticism and stirring practical suggestions as it is fascinating in matter and style. I do not know anything equal to it in the field it covers."—*J. L. Chamberlain, LL.D., President of Bowdoin College*.

**Mathews — Literary Style; and Other Essays.** By WILLIAM MATHEWS, LL.D. 12mo, cloth, \$1.50.

"Its influence is excellent and ennobling."—*Standard*, Chicago.

"Can be dipped into anywhere with the certainty of finding something good and something worth remembering."—*Transcript*, Boston.

**Morris—British Thought and Thinkers.** Introductory Studies, Critical, Biographical and Philosophical. By GEORGE S. MORRIS, Ph.D. 12mo, cloth, \$1.75.

"It presents wise reflection, entertaining speculation, valuable literary criticism, and a large amount of interesting biographical matter, given with the skill of a practised writer and the force and authority of an able and powerful mind. It is a book of great value and deep interest."—*Courier*, Boston.

**Morris—Manual of Classical Literature.** Comprising Biographical and Critical Notices of principal Greek and Roman Authors, Illustrative Extracts from their Works, etc. By CHARLES MORRIS. 12mo, cloth, \$1.75.

"The book presents a more complete survey of classical literature than can elsewhere be found in the same compass."—*Scotsman*, Edinburgh, Scotland.

**Miller—What Tommy Did.** By EMILY HUNTINGTON MILLER. Illustrated 16mo, paper covers, 50 cents; cloth, \$1.

"We laughed all the evening over the many funny things Tommy said and did. We will warrant that no one, young or old, will lay it down until read through."—*Northern Christian Advocate*.

**Mishaps of Mr. Ezekiel Pelter.** Illustrated. \$1.50.

"If it be your desire to 'laugh and grow fat,' you will find The Mishaps of Ezekiel Pelter a great help."—*American Christian Review*, Cincinnati.

**Raymond—The Orator's Manual.** A practical and philosophical treatise on Vocal Culture, Emphasis and Gesture, with selections for Declamation and Reading. For Schools and Colleges, and for Public Speakers and Readers. By G. L. RAYMOND, M.A., Prof. of Oratory, Princeton College. \$1.50.

"The freshest, clearest, most complete and soundly philosophical work on a public speaker's training that it has been our fortune to meet. In form and substance it is admirable. A faithful study and practice of the principles and examples of this book will result in a natural, graceful and effective style of public speaking."—*Christian Union*, New York.

**Robertson's Living Thoughts.** A Thesaurus. Selected from the writings of FREDERICK W. ROBERTSON by K. B. TUPPER. With an Analytical Index. 12mo, cloth. \$1.25.

"This volume contains the cream of his writings."—*Transcript*, Boston.

**Rogers—The Waverley Dictionary.** An Alphabetical Arrangement of all the Characters in Sir Walter Scott's Novels, with a Descriptive Analysis of each Character, and Illustrative Selections from the Text. By MAY ROGERS. 12mo. cloth, \$2; half calf, gilt top, \$3.50; full calf, gilt edges, \$5.

"The selections are made with excellent judgment, and form a worthy muster-roll of the most immortal of all the Scottish clans."—*Appleton's Year*.

**Robert—Rules of Order for Deliberative Assemblies.** By MAJOR HENRY M. ROBERT. Pocket Size. Cloth, 75 cents.

*The Standard Parliamentary Authority in the United States.*

"The best book extant."—*Hon. J. W. Husted, late Speaker N. Y. Legislature.*

"The most conspicuous and comprehensive embodiment of the rules observed in American assemblies that I have ever seen. It should be studied by all who wish to become familiar with the correct usages of public meetings."—*Bishop Haven.*

**Taylor—Songs of Yesterday.** By BENJ. F. TAYLOR. Beautifully illustrated. Octavo, with handsomely ornamented cover in black and gold. Full gilt edges, \$3.

"The volume is magnificently gotten up. . . . There is a simplicity, a tenderness and a pathos, intermingled always with a quiet humor, about his writings, which is inexpressibly charming. Some of his earlier poems have become classic, and many of those in this volume are destined to as wide a popularity as Longfellow's 'Village Blacksmith' or Whittier's 'Maud Muller.'"—*Transcript, Boston.*

**Taylor—Between the Gates.** By BENJ. F. TAYLOR. Illustrated. 12mo, cloth, \$1.50.

"It is the richest, raciest and most readable book of the kind that we ever read. . . . It gives a better and clearer view of California life, climate and customs, than has ever before been written."—*Evangel, San Francisco.*

**Taylor—Summer Savory.** By BENJ. F. TAYLOR. Cloth, \$1.

"A delightful work, crammed full with brilliant sketches that combine piquancy, freshness, power and humor."—*Record, Philadelphia.*

**Taylor—Pictures of Life in Camp and Field.** By BENJ. F. TAYLOR. 12mo, cloth, \$1.00.

"Each of these sketches is a gem in itself. One may search the annals of war from Tacitus to Kinglake and not find anything finer."—*Inter Ocean.*

**Taylor—Old-Time Pictures and Sheaves of Rhyme.** By BENJ. F. TAYLOR. Illustrated. Small quarto, silk cloth, \$1.50; the same, full gilt edges and side, \$1.75.

"I do not know of any one who so well reproduces the home scenes of long ago."—*John G. Whittier.*

**Taylor—The World on Wheels, and Other Sketches.** By BENJ. F. TAYLOR. Illustrated. 12mo, cloth, \$1.

"One of the most elegant, as well as pungent and rich, specimens of wit and humor extant."—*Illustrated Weekly, New York.*

"Few equal Mr. Taylor as a word-painter. He fascinates with his artistic touches, and exhilarates with his sparkling humor, and subdues with his sweet pathos. His sentences glisten like gems in the sunlight."—*Journal, Albany.*



**Welsh—The Development of English Literature and Language.** By Prof. A. H. WELSH. 2 vols., 1100 pages. Crown octavo, cloth, \$5; half calf, \$8; full turkey morocco, gilt edges, \$12.

"A really great work."—*Press*, Philadelphia.

"As complete in its survey as it is attractive in style and manner."—*Critic*.

"The plan is excellent and the execution felicitous."—*Edwin P. Whipple*.

"The volumes, considered merely as a work of reference, must enter the library of every student of literature."—*Edmund Clarence Stedman*.

"The best work for the general reader that has yet been published, and we unreservedly recommend it to the student as well, for its learning, very perfect treatment and its style. . . . The criticisms of American authors will be found to be analytical, exhaustive and terse, and to be the finest examples of such work. The articles on Hawthorne and Emerson, which are complete, have never been equalled."—*Globe*, Boston.

**Wheeler—The Foreigner in China.** By L. N. WHEELER, D.D. 12mo, cloth, \$1.25.

"The fruits of his observations embrace much heretofore unknown to the general public, and readers will find the book exceptionally interesting."—*Transcript*, Boston.

**Winchell—Preadamites; or, A Demonstration of the Existence of Men before Adam.** Together with a Study of their Condition, Antiquities, Racial Affinities, and Progressive Dispersion over the Earth. With Charts and Illustrations. By ALEXANDER WINCHELL, LL.D., Prof. of Geology and Palæontology in the University of Michigan; Author of "Sketches of Creation," etc. 8vo, cloth, \$3.50.

"A remarkable and powerful contribution to the reconciliation of the Bible and modern science."—*Literary World*, Boston.

"The work is popular in its best sense—attractive in style, clear in exposition, and eminently instructive. . . . It is not too much to say that it settles the controversy."—*Popular Science Monthly*.

**Winchell—Sparks from a Geologist's Hammer.** By ALEX. WINCHELL, LL.D. Illustrated. 12mo, cloth, \$2.

"This superb work is of thrilling interest to every reader who has an intelligent desire to know more of this wonderful planet on which we live. . . . The chapter, 'A Grasp of Geologic Time,' is worth more to the general reader than the price of the whole book. . . . The plan of this book is most admirable. Prof. Winchell's first chapter takes the reader upon an interesting excursion to Mont Blanc and the Mer de Glace, where the æsthetic aspect of geology, as there so beautifully displayed, is presented. This is followed by three chapters on 'The Old Age of the Continents,' 'Obliterated Continents,' and 'A Grasp of Geologic Time'; following with other chapters, Climatic, Historical and Philosophical. It is a treasure which should find a cherished place in every family library."—*Home Journal*, Boston.

\*Any of these books will be sent by mail, post-paid, on receipt of the price, by the publishers.

